

SP-5



Equipment Solutions



Portable, Reliable, Rugged Design

Your metering and mixing solution for joint filling and sealing.

BENEFITS

- Adjustable flow rate
- Better dispensing control of joint filling, sealing, and caulking
- Ideal for Single-Component Silicones, Urethanes, and Fire Stop
- External check valve
- Pneumatically controlled elevator
- Self-priming
- Few moving parts, easy operation, and maintenance

SPECIFICATIONS

Dimensions: 16" L x 24" W x 48" H (200 lbs.)

Volume Output: up to 0.25 gpm

Tank Size: No Tank

Cycle Rate: Up to 30 cycles/min

Viscosity Range: 1 to 1,000,000 CPS

Services Required: Clean, dry, compressed air 6 cfm @ 90 psi

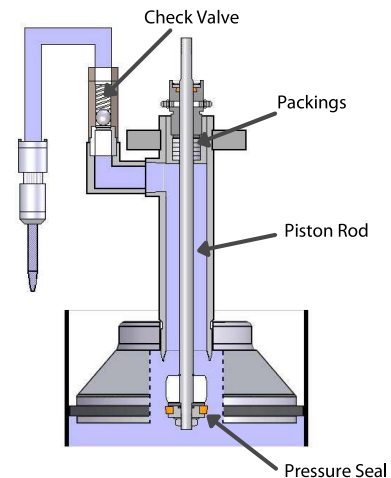

NORTH AMERICA BASED. CUSTOMER FOCUSED.

With 25+ locations across the continent, APPLIED offers a stronger supply chain, localized sales reps, and shorter delivery times. We combine groundbreaking adhesive and sealant solutions with industry-leading expertise and the highest-quality dispensing equipment. Since 1971, APPLIED directly manages every step of the process giving our customers turnkey solutions with lower overhead. It also provides a strategic advantage by avoiding issues related to importing from overseas, eliminating tariff surprises and international shipping delays.

Your custom adhesive solutions provider.



Visit us at
appliedadhesives.com



Call us today
(763) 592-2063



6035 Baker Road
Minnetonka, MN 55345



[construction@
appliedproducts.com](mailto:construction@appliedproducts.com)