

Installation - Parts



E-Flo[®] SP Electric Pumps for Sealants and Adhesives

3A6586A

EN

For use with single-component sealant and adhesive materials. For professional use only.

Not approved for use in explosive atmospheres or hazardous locations.

See page 3 for model information, including maximum working pressure and approvals.



Important Safety Instructions

Read all warnings and instructions in this manual and in all related manuals before using the equipment. Save all instructions.

EC100CS2

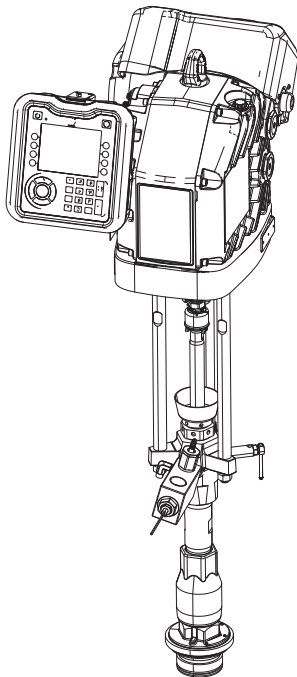

ED145SS2

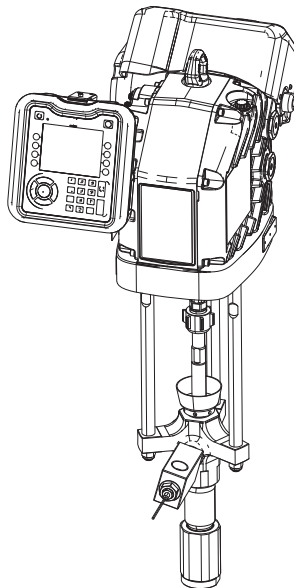

ED145CS2

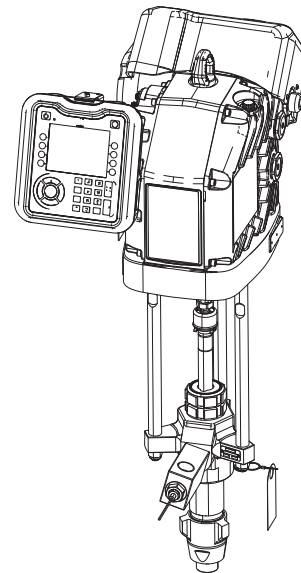

PROVEN QUALITY. LEADING TECHNOLOGY.

Contents

Related Manuals	2	Parts	18
Models	3	Electric Pumps with Check-Mate Lowers	18
System Pressure	4	Electric Pumps with Dura-Flo Lowers	22
Warnings	5	Check Valves	25
Component Identification	7	Kits and Accessories	28
Electric Pump with 220 cc Dura-Flo CS Lower ..	7	Advanced Display Module Kit 25E439	28
Advanced Display Module (ADM)	8	Communication Gateway Module (CGM) Kits ..	29
Installation	9	Inlet Pressure Sensor Kit, 24Y245	30
Location and Mounting	9	Pump Stand Frame, 253692	31
Grounding	9	Wall Mount Bracket, 255143	31
Power Requirements	9	Floor Mount Adapter, 223952	32
Connect Power	10	CAN Cables	32
Connect the Standalone Transformer	11	Dimensions	33
Install Vented Oil Cap Before Using Equipment.	12	E-Flo SP Pump Dimensions	33
Fluid Hose Connection	12	Pump Stand Mounting Hole Diagram	34
Connecting Multiple Pumps	13	Floor Stand Mounting Hole Diagram	35
Setup	14	Electric Driver Mounting Hole Pattern	35
Wet Cup	14	Transformer Mounting Hole Diagram	36
Flush the Pump	14	Pump Performance	37
Pressure Relief Procedure	16	Technical Specifications	38
Shutdown and Care of the Pump	16	Graco Standard Warranty	40
Driver Maintenance	17		

Related Manuals

Component Manuals in U.S. English

Manual	Description
3A6331	E-Flo SP Supply Systems Instructions-Parts
3A6724	E-Flo SP Software Instructions
3A6482	APD20 Driver Instructions-Parts
312375	Check-Mate® 100cc, 200cc, 250cc, 500cc CS/CM/SS/SM Lower Instructions-Parts List
311762	Dura-Flo™ 145cc, 180cc, 220cc, 290cc CS Lower Instructions-Parts List
311827	Dura-Flo™ 145cc, 180cc, 220cc, 290cc SS Lower Instructions-Parts List
311825	Dura-Flo™ 430cc CS/SS/SM Lower Instructions-Parts List
3A6321	ADM Token In-System Programming
3A1244	Graco Control Architecture™ Module Programming
311619	Pump Mounting Kits
307971	Floor Stand Accessory

Models

Check your pump package's identification (ID) label located on the side of the electric driver for the 8-digit part number of your pump package. Use the following matrix to identify the construction of your pump package based on the eight digits.

For example: model **EC100CS3** is an electric (**E**) Check-Mate (**C**) 100 cc (**100**) pump with a carbon steel (**C**) Severe Duty® (**S**) lower, an Advanced Display Module (ADM), and 240 VAC power (**3**).

NOTE: Each Check-Mate pump size is available in CS, CM, SS, and SM pump materials. Dura-Flo pump material combinations depend on the pump size. For Dura-Flo pumps, MaxLife® is only available with the 430 cc stainless steel pump lower. Refer to the matrix below.

To order replacement parts, see the **Parts** section starting on page **18**.

Pump Style		Pump Type		Pump Size		Pump Material		Interface / Power																
1st Digit		2nd Digit		3rd, 4th & 5th Digit		6th Digit		7th Digit		8th Digit														
E	Electric Pump	C	Check-Mate	100	100 cc Check-Mate	C	Carbon Steel	S	Severe Duty	1	None	240 VAC												
				200	200 cc Check-Mate								S	Stainless Steel	M	MaxLife	2	ADM	240 VAC					
				250	250 cc Check-Mate															3	None	480 VAC		
				500	200 cc Check-Mate																		4	ADM
E	Electric Pump	D	Dura-Flo	115	115 cc Dura-Flo	C	Carbon Steel	S	Severe Duty	1	None	240 VAC												
				145	145 cc Dura-Flo								S	Stainless Steel	3	None	480 VAC							
				180	180 cc Dura-Flo													4	ADM	480 VAC				
				220	220 cc Dura-Flo																			
				290	290 cc Dura-Flo																			
				430	430 cc Dura-Flo																			
				430	430 cc Dura-Flo																S	Stainless Steel	M	MaxLife
				430	430 cc Dura-Flo																			

NOTE: A single electric pump must include an ADM. Up to six pumps can be connected in a system and controlled by a single ADM. See **Connecting Multiple Pumps** on page **13**.

Approvals



System Pressure

Due to factors such as the dispensing system design, the material being pumped, and the flow rate, the dynamic pressure will not reach the rated working (stall) pressure of the system.











	Lower Size	Pump Working (Stall) Pressure			Max Dynamic (Run) Pressure		
		psi	bar	MPa	psi	bar	MPa
Check-Mate	100CS/CM/SS/SM	6,000	414	41.4	6,000	414	41.4
	200CS/CM/SS/SM	4,200	290	29.0	3,905	269	26.9
	250CS/CM/SS/SM	3,400	234	23.4	3,122	215	21.5
	500CS/CM/SS/SM	1,600	110	11.0	1,487	103	10.3
Dura-Flow	145SS	5,600	386	38.6	5,204	359	35.9
	180SS	4,500	310	31.0	4,164	287	28.7
	220SS	3,700	255	25.5	3,470	239	23.9
	290SS	2,800	193	19.3	2,602	179	17.9
	430CS/SS/SM	1,900	131	13.1	1,735	120	12.0
	115CS	6,000	414	41.4	6,000	414	41.4
	145CS	5,600	386	38.6	5,204	359	35.9
	180CS	4,500	310	31.0	4,164	287	28.7
	220CS	3,700	255	25.5	3,472	239	23.9
	290CS	2,800	193	19.3	2,602	179	17.9

Flow Rate Table



	Lower Size	Flow Rate (cc/min)	Flow Rate (gpm)	Outlet Fitting Size
Check-Mate	100CS/CM/SS/SM	2,500	0.66	1 in. NPT female
	100CS/CM/SS/SM	5,000	1.32	1 in. NPT female
	100CS/CM/SS/SM	6,250	1.65	1 in. NPT female
	100CS/CM/SS/SM	12,500	3.30	1-1/2 in. NPT female
Dura-Flow	145SS	3,625	0.96	1 in. NPT female
	180SS	4,500	1.19	1 in. NPT female
	220SS	5,500	1.45	1 in. NPT female
	290SS	7,250	1.92	1 in. NPT female
	430CS/SS/SM	10,750	2.84	1-1/2 in. NPT female
	115CS	2,875	0.76	1 in. NPT female
	145CS	3,625	0.96	1 in. NPT female
	180CS	4,500	1.19	1 in. NPT female
	220CS	5,500	1.45	1 in. NPT female
	290CS	7,250	1.92	1 in. NPT female

Warnings

The following warnings are for the setup, use, grounding, maintenance, and repair of this equipment. The exclamation point symbol alerts you to a general warning and the hazard symbols refer to procedure-specific risks. When these symbols appear in the body of this manual or on warning labels, refer back to these Warnings. Product-specific hazard symbols and warnings not covered in this section may appear throughout the body of this manual where applicable.

 DANGER	
	<p>SEVERE ELECTRIC SHOCK HAZARD</p> <p>This equipment can be powered by more than 240 V. Contact with this voltage will cause death or serious injury.</p> <ul style="list-style-type: none"> • Turn off and disconnect power at main switch before disconnecting any cables and before servicing equipment. • This equipment must be grounded. Connect only to grounded power source. • All electrical wiring must be done by a qualified electrician and comply with all local codes and regulations.
 WARNING	
    	<p>SKIN INJECTION HAZARD</p> <p>High-pressure fluid from dispensing device, hose leaks, or ruptured components will pierce skin. This may look like just a cut, but it is a serious injury that can result in amputation. Get immediate surgical treatment.</p> <ul style="list-style-type: none"> • Do not point dispensing device at anyone or at any part of the body. • Do not put your hand over the fluid outlet. • Do not stop or deflect leaks with your hand, body, glove, or rag. • Follow the Pressure Relief Procedure when you stop dispensing and before cleaning, checking, or servicing equipment. • Tighten all fluid connections before operating the equipment. • Check hoses and couplings daily. Replace worn or damaged parts immediately.
 	<p>MOVING PARTS HAZARD</p> <p>Moving parts can pinch, cut or amputate fingers and other body parts.</p> <ul style="list-style-type: none"> • Keep clear of moving parts. • Do not operate equipment with protective guards or covers removed. • Pressurized equipment can start without warning. Before checking, moving, or servicing equipment, follow the Pressure Relief Procedure and disconnect all power sources.

WARNING

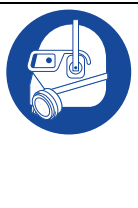
	<p>FIRE AND EXPLOSION HAZARD</p> <p>Flammable fumes, such as solvent and paint fumes, in work area can ignite or explode. Paint or solvent flowing through the equipment can cause static sparking. To help prevent fire and explosion:</p> <ul style="list-style-type: none"> • Use equipment only in well-ventilated area. • Eliminate all ignition sources; such as pilot lights, cigarettes, portable electric lamps, and plastic drop cloths (potential static sparking). • Ground all equipment in the work area. See Grounding instructions. • Never spray or flush solvent at high pressure. • Keep work area free of debris, including solvent, rags and gasoline. • Do not plug or unplug power cords, or turn power or light switches on or off when flammable fumes are present. • Use only grounded hoses. • Hold gun firmly to side of grounded pail when triggering into pail. Do not use pail liners unless they are anti-static or conductive. • Stop operation immediately if static sparking occurs or you feel a shock. Do not use equipment until you identify and correct the problem. • Keep a working fire extinguisher in the work area.
	<p>TOXIC FLUID OR FUMES HAZARD</p> <p>Toxic fluids or fumes can cause serious injury or death if splashed in the eyes or on skin, inhaled, or swallowed.</p> <ul style="list-style-type: none"> • Read Safety Data Sheets (SDSs) to know the specific hazards of the fluids you are using. • Store hazardous fluid in approved containers, and dispose of it according to applicable guidelines.
	<p>EQUIPMENT MISUSE HAZARD</p> <p>Misuse can cause death or serious injury.</p> <ul style="list-style-type: none"> • Do not operate the unit when fatigued or under the influence of drugs or alcohol. • Do not exceed the maximum working pressure or temperature rating of the lowest rated system component. See Technical Specifications in all equipment manuals. • Use fluids and solvents that are compatible with equipment wetted parts. See Technical Specifications in all equipment manuals. Read fluid and solvent manufacturer's warnings. For complete information about your material, request Safety Data Sheets (SDSs) from distributor or retailer. • Turn off all equipment and follow the Pressure Relief Procedure when equipment is not in use. • Check equipment daily. Repair or replace worn or damaged parts immediately with genuine manufacturer's replacement parts only. • Do not alter or modify equipment. Alterations or modifications may void agency approvals and create safety hazards. • Make sure all equipment is rated and approved for the environment in which you are using it. • Use equipment only for its intended purpose. Call your distributor for information. • Route hoses and cables away from traffic areas, sharp edges, moving parts, and hot surfaces. • Do not kink or over bend hoses or use hoses to pull equipment. • Keep children and animals away from work area. • Comply with all applicable safety regulations.
	<p>PERSONAL PROTECTIVE EQUIPMENT</p> <p>Wear appropriate protective equipment when in the work area to help prevent serious injury, including eye injury, hearing loss, inhalation of toxic fumes, and burns. Protective equipment includes but is not limited to:</p> <ul style="list-style-type: none"> • Protective eyewear, and hearing protection. • Respirators, protective clothing, and gloves as recommended by the fluid and solvent manufacturer.

Component Identification

Electric Pump with 220 cc Dura-Flo CS Lower

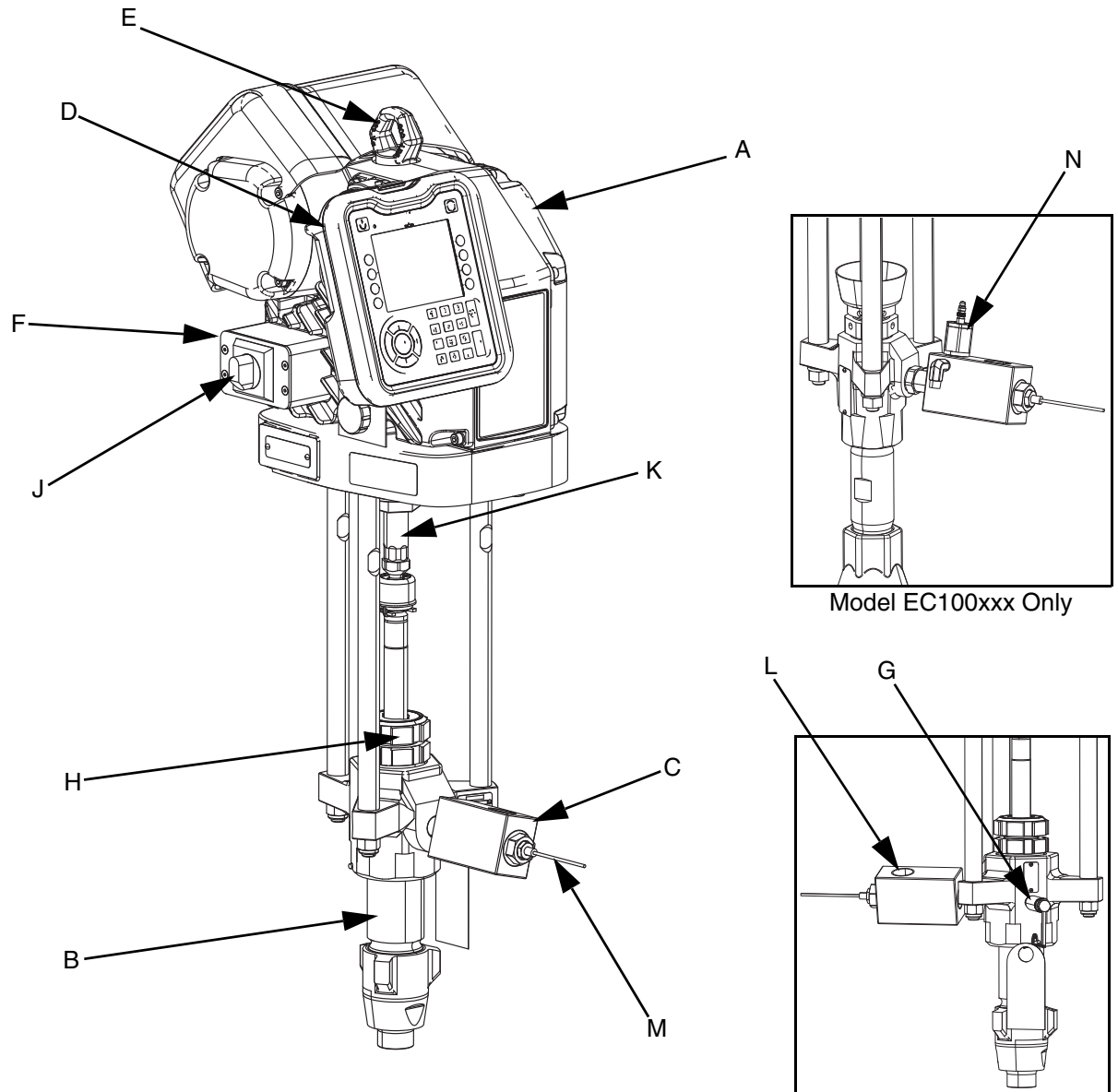

FIG. 1: E-Flo SP Components

Key:

- | | | | |
|---|-------------------------------|---|----------------------------|
| A | Electric Driver | H | Wet Cup |
| B | Displacement Pump | J | Disconnect Switch |
| C | Check Valve Block | K | Driver Output Shaft |
| D | Advanced Display Module (ADM) | L | Fluid Hose Connection |
| E | Lift Ring | M | Pressure Transducer Sensor |
| F | Power Junction Box | N | Pressure Relief Valve |
| G | Pump Bleed Valve | | |

Advanced Display Module (ADM)

Front and Rear Views

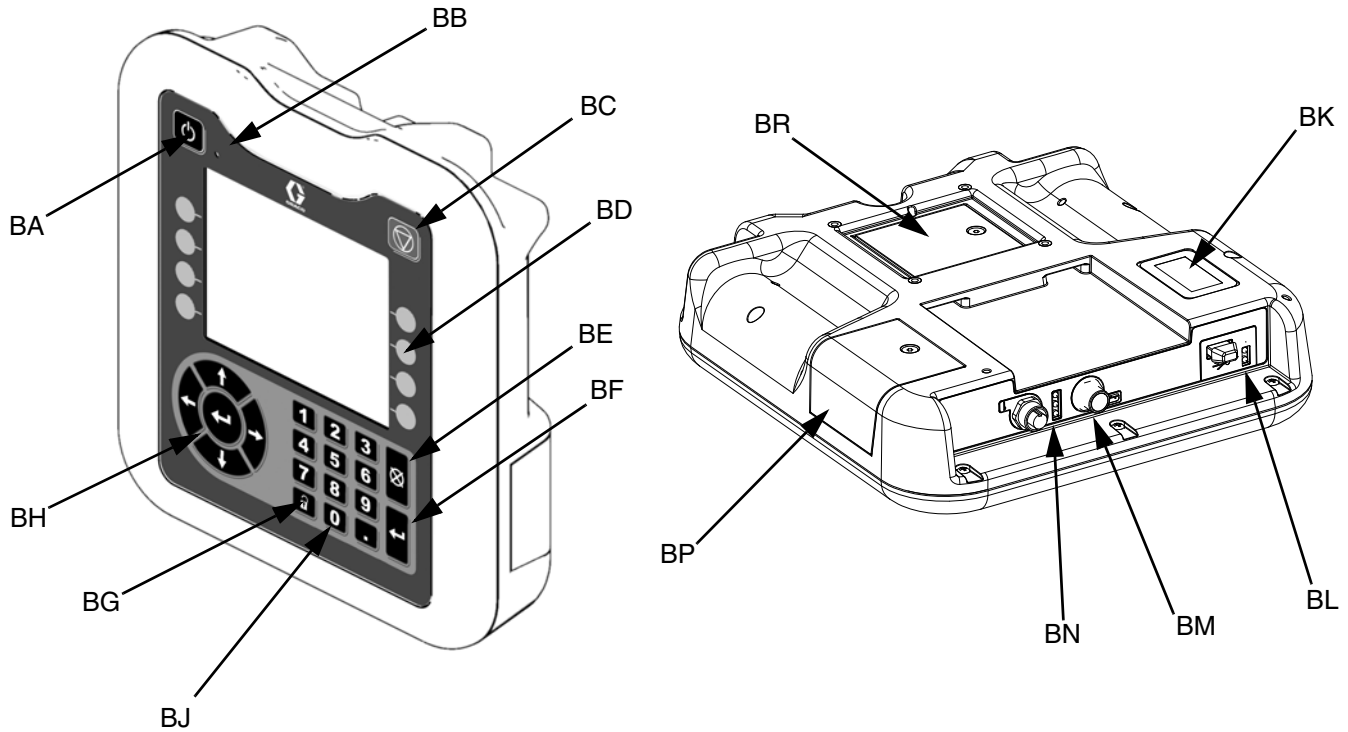

FIG. 2: ADM Component Identification

Key:

- BA Pump Enable**
Enables the pump. Toggles between Active and System Off.
- BB Pump Status Indicator Light**
- BC Pump Soft Stop**
Stops all pump processes and disables the pump.
- BD Soft Keys**
Defined by the icon on the screen next to the soft key.
- BE Cancel**
Cancel a selection or number entry while in the process of entering a number or making a selection. Cancels the pump processes.
- BF Enter**
Accept change, acknowledge error, select item, and toggle selected item.

- BG Lock/Setup**
Toggle between run and setup screens.
- BH Directional Keypad**
Navigate within a screen or to a new screen.
- BJ Numeric Keypad**
- BK Part Number Identification Label**
- BL USB Interface**
- BM CAN Cable Connection**
Power and communication.
- BN Module Status LEDs**
Visual indicators to show the status of the ADM.
- BP Token Access Cover**
Access cover for software token.
- BR Battery Access Cover**

Installation

Accessories are available from Graco. Make certain accessories such as hoses are adequately sized and pressure-rated to meet the system's requirements.

Location and Mounting

To properly locate and mount the pump, refer to **Dimensions** starting on page **33**. Always position the pump so the driver, disconnect switch, and ADM are easily accessible.

Attach a chain or hook at the proper lift location. Lift off the pallet using a crane or a forklift. See the lift ring (E) in **Figure 1** on page **7**.

NOTICE
Always lift the pump at the proper lift location (E). Do not lift in any other way. Failure to lift at the proper lift location can result in damage to the pump system.

Three pump mounting options are available from Graco: a pump stand, a wall mount, and a floor mount adapter. See **Kits and Accessories** starting on page **28** for information about installing a pump using these mounting options.

Always ensure the pump is level. If you are using the pump stand, you can level the base using metal shims if necessary. Secure the stand or floor mount using anchors that are long enough to prevent the pump from tipping.

Refer to the **Electric Driver Mounting Hole Pattern** on page **35** to mount the driver to the stand or wall mount once you have properly secured them to the floor or wall.

Grounding

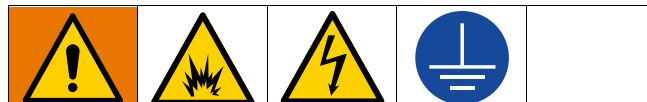

The equipment must be grounded to reduce the risk of static sparking and electric shock. Electric or static sparking can cause fumes to ignite or explode. Improper grounding can cause electric shock. Grounding provides an escape wire for the electric current.

Electric pump: the pump is grounded through the power cord.

Fluid hoses: use only electrically conductive hoses with a maximum of 500 ft. (150 m) combined hose length to ensure grounding continuity. Check the electrical resistance of the hoses. If the total resistance to ground exceeds 29 megaohms, replace the hose immediately.

Dispense valve: ground through connection to a properly grounded fluid hose and pump.

Fluid supply container: follow local code.

Solvent pails used when flushing: follow local code. Use only conductive metal pails, placed on a grounded surface. Do not place the pail on a non-conductive surface, such as paper or cardboard, which interrupts the grounding continuity.

To maintain grounding continuity when flushing or relieving pressure: hold a metal part of the dispense valve firmly to the side of a grounded metal pail, then trigger the valve.

Power Requirements

The system requires a dedicated circuit protected with a circuit breaker.

Voltage	Phase	Hz	Current
200-240 VAC	1	50/60	20 A
400-480 VAC	1	50/60	10 A

Connect Power

All electrical wiring must be done by a qualified electrician and comply with all local codes and regulations.

Letters in parenthesis are used in this section for reference to callouts in the **Component Identification** section starting on page 7.

1. Cut power cord wires to the following lengths:
 - Ground wire - 6.5 inches (16.5 cm)
 - Power wires - 3.0 inches (7.6 cm)
 - Add ferrules as necessary. See **Figure 3**.

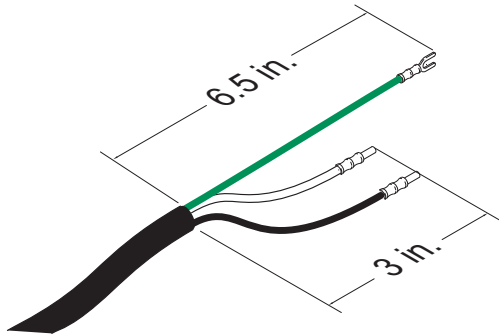

FIG. 3: Power Cord

2. Remove the four screws to separate the junction box cover and disconnect switch (J) from the junction box (F) on the electric driver.

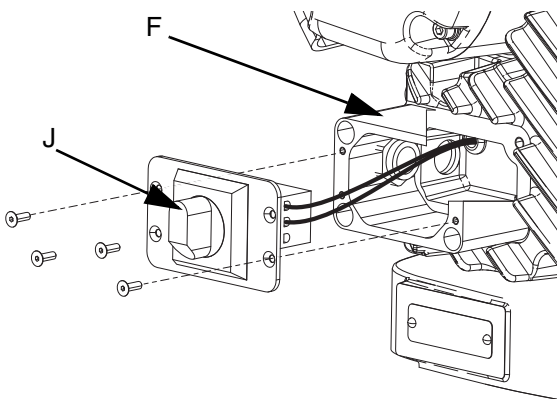

FIG. 4: Remove Junction Box Cover

NOTE: Inside the junction box, power wires to the driver are connected to terminals 3L2 and 5L3 on the disconnect block. Refer to **Figure 5** for the terminal locations.

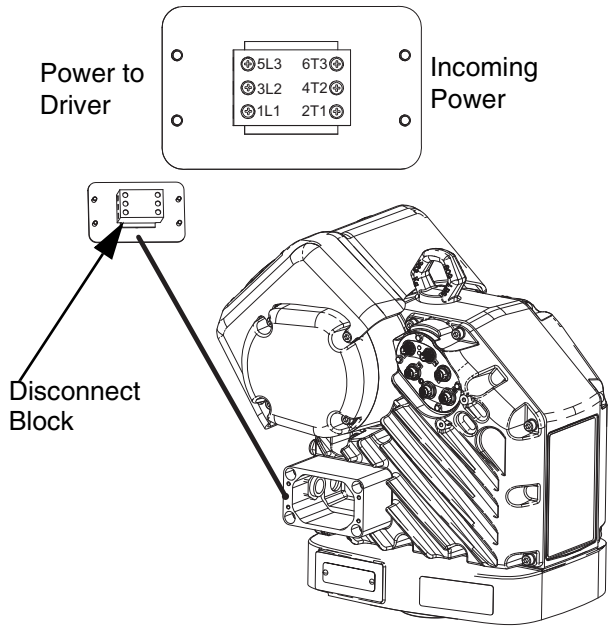

FIG. 5: Terminal Connections

3. Insert the power cord through the cord grip and into the junction box.

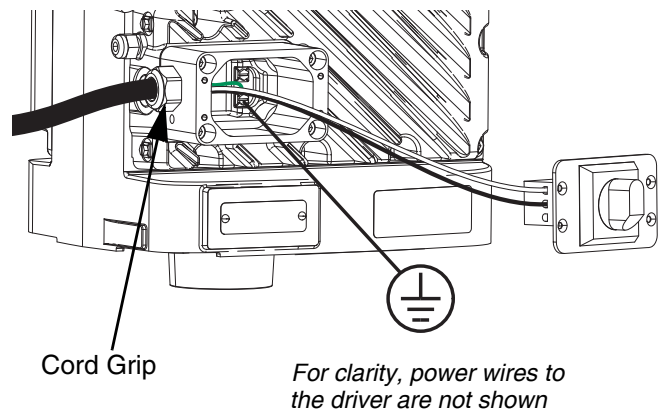

FIG. 6: Connect Power

4. Refer to **Figure 5** and connect the wires from the power cord into terminals 4T2 and 6T3. Each wire can be connected to either terminal.
5. Attach the ground wire to one of the two ground terminals inside the junction box as shown in **Figure 6**.

NOTE: Do not attach the ground wire to the grounding lug locknut located by the wiring cord grip on the outside of the electric driver. The lug locknut should only be used for other grounding purposes if needed.

- Place the power wires into the open area on either side of the disconnect block as space permits.
- Reinstall the junction box cover and disconnect switch (J) using the four screws removed in step 2.

NOTICE

If wires get pinched when the screws are tightened, damage will occur. Make sure all wires are routed correctly before installation.

- Tighten the cord grip to securely hold the power cord in the junction box.

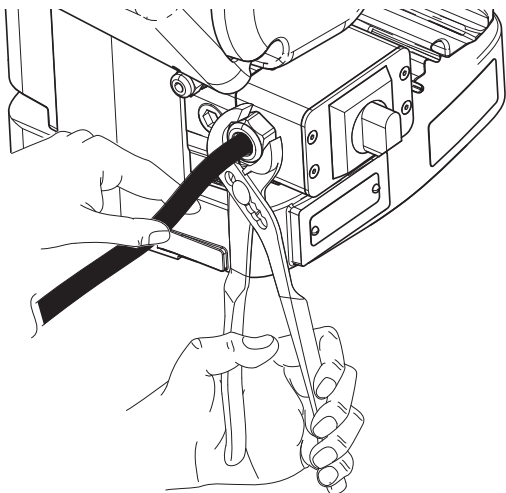

FIG. 7: Tighten Cord Grip

Connect the Standalone Transformer



All electrical wiring must be done by a qualified electrician and comply with all local codes and regulations.

Units rated 480 VAC are shipped with a standalone transformer, part no. 25E268. Mount the transformer near the pump in a secure location that prevents damage to the transformer or the wiring to the pump.

- Refer to the **Transformer Mounting Hole Diagram** on page 36 and use the mounting holes as a guide to drill holes for 1/4 in. (6 mm) screws.
- Attach the transformer securely to the mounting surface.
- Remove the four screws on the transformer as shown in **Figure 8** and remove the front cover.

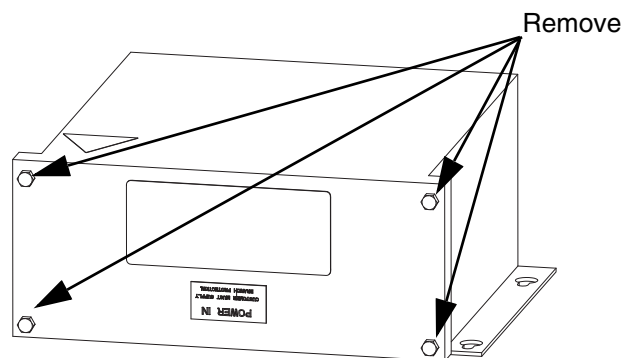

FIG. 8: Standalone Transformer

- Insert the power cord (not included) through a punch-out on the side of the transformer. A cord grip or conduit connection (not included) must be used where wiring passes through the punch-out.
- Refer to **Figure 9** on page 12 and connect the wires from the power cord to the wires marked H1 and H2 inside the transformer.
- Connect the power cord ground wire to the grounding bar inside the transformer as shown in **Figure 9** on page 12.

7. Connect wiring (not included) to X1 and X2 and a ground wire to the grounding bar. This wiring is for connection to the pump.

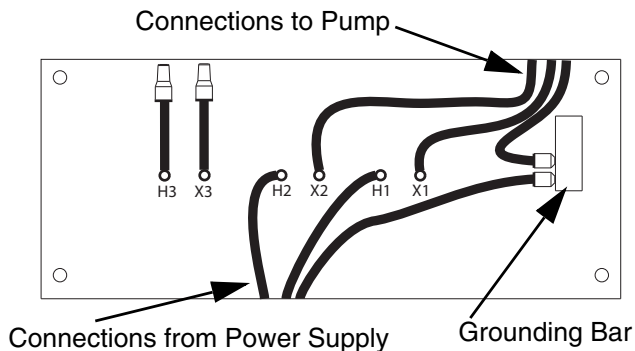

Fig. 9: Transformer Wiring Connections

NOTE: The other wires shown in **Figure 9** (H3, X3) are connected at the factory and are not required for connecting the transformer to the pump.

8. Run the wiring to the pump out through one of the punch-outs in the side of the transformer cover. A cord grip or conduit connection (not included) must be used where wiring passes through the punch-out.
9. Reattach the front cover using the four screws removed in step 3.
10. Connect the wiring from the transformer into terminals 4T2 and 6T3 inside the junction box and attach the ground wire to one of the two ground terminals inside the junction box as described in **Connect Power** on page 10.

Install Vented Oil Cap Before Using Equipment.

The driver gear-box is shipped from the factory pre-filled with oil. The temporary unvented cap prevents oil leaks during shipment. Before use, this temporary cap must be replaced with the vented oil cap supplied with the equipment.

NOTE: Prior to use, check oil level. Oil level should be half way up the sight glass.

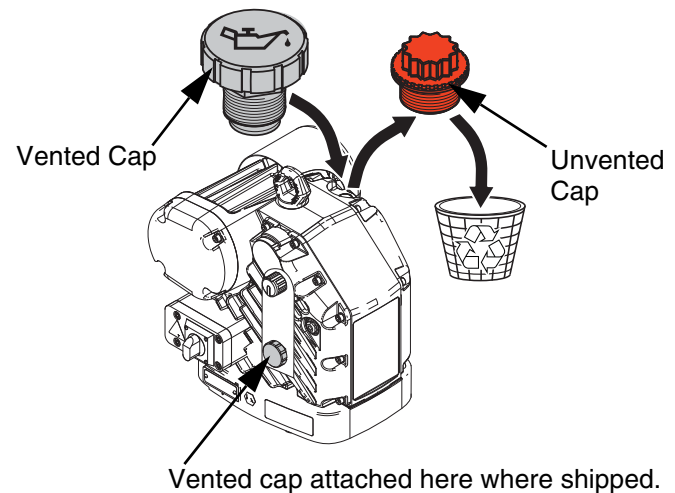

Fig. 10: Unvented and Vented Oil Caps

Fluid Hose Connection

Refer to **Figure 1** on page 7.

Attach the fluid hose (not supplied) to the check valve fluid hose connection (L).

NOTE: Be sure all components are adequately sized and pressure rated to meet the system's requirements.

Connecting Multiple Pumps

Up to six E-Flo SP pumps can be connected together and operated from one Advanced Display Module (ADM). This can be configured with or without a Communication Gateway Module (CGM).

The following components are required for connecting the pumps, based on the configuration of your system:

- 1 pump with an ADM
- 1 to 5 additional pumps without an ADM
- 1 CAN cable for connecting each pump
- 1 splitter (part no. 121807)
- 1 CAN cable to connect the last pump to the splitter (or CGM)

The following are optional for connecting the pumps:

- 1 CGM
- 1 cable to connect the CGM to the splitter

Connect the Pumps

NOTE: Refer to **Figure 11** for the following steps. **Figure 11** shows four pumps connected. The ADM can be mounted on the first pump or at a location separate from the pump.

1. Connect a CAN cable from port 1 on the first pump (shown as Pump 1 in **Figure 11**) to the splitter.
2. Connect a second CAN cable from the splitter to the ADM.
3. Connect a third CAN cable to port 1 on the CGM.

NOTE: **Figure 11** shows the configuration with a CGM. If you are not using a CGM, the CAN cable from the last pump is connected directly to the splitter.

4. Connect another CAN cable from port 2 on Pump 1 to port 1 on Pump 2.
5. Use additional CAN cables to make the same connections between each pump.
6. Connect the last pump in the system from port 2 on the pump to the CGM at port 2 or directly to the splitter.
7. Refer to the E-Flo SP Software Instructions manual for information about configuring and operating multiple pumps. See **Related Manuals** on page 2.

NOTE: Refer to **CAN Cables** on page 32 for a listing of available cables.

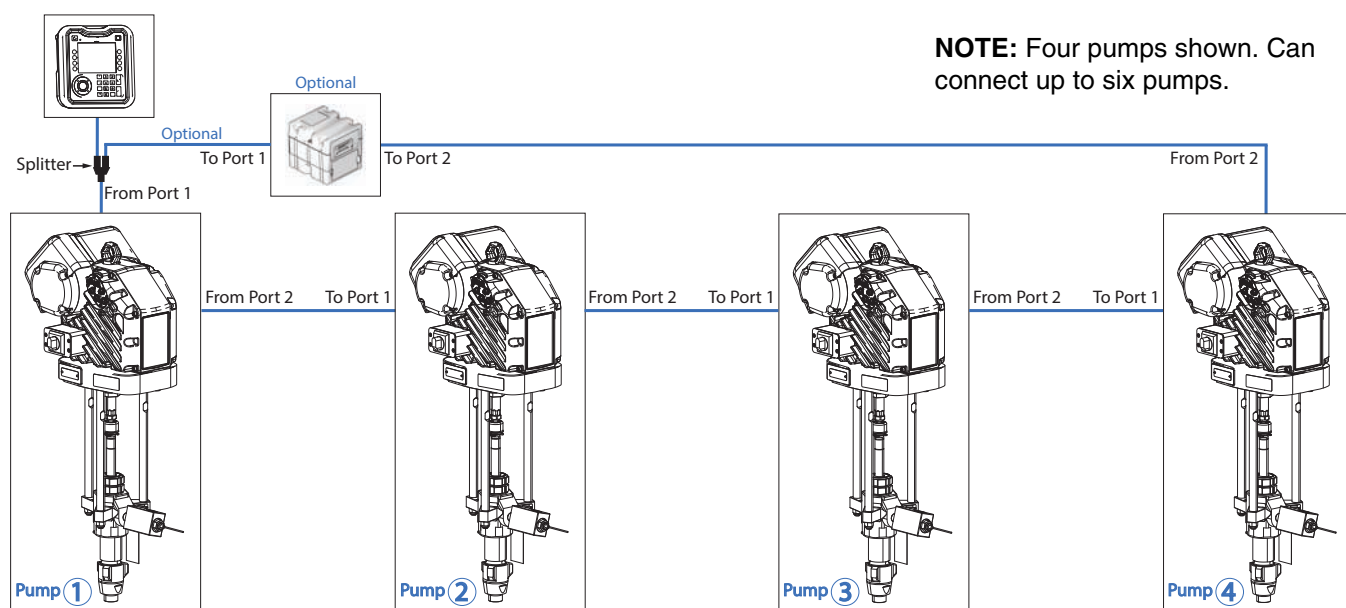

NOTE: Four pumps shown. Can connect up to six pumps.

FIG. 11: Multiple Pump Connections

Setup

Letters in parenthesis are used in this section for reference to callouts in the **Component Identification** section starting on page 7.

NOTE: Refer to the E-Flo SP Software Instructions manual for ADM setup instructions. See **Related Manuals** on page 2.

Wet Cup



Before starting, fill the wet cup (H) 1/3 full with Graco Throat Seal Liquid (TSL) or a compatible solvent.

Torque the Wet Cup

The wet cup is torqued at the factory; however, throat packing seals on the pumps may relax over time. Check wet cup torque frequently after initial start-up and periodically after the first week of production. Maintaining proper wet cup torque is important to extending seal life.

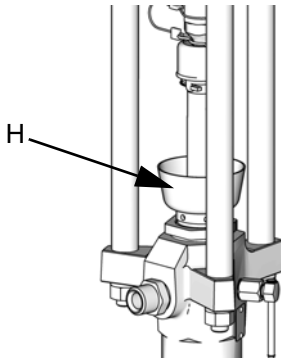
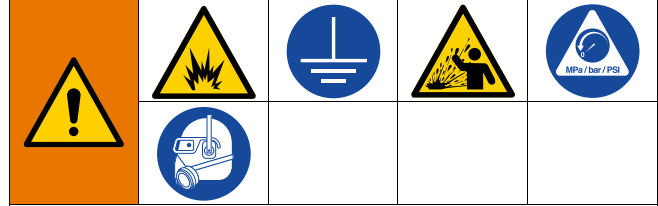

FIG. 12: Wet Cup

Flush the Pump



To avoid fire and explosion, always ground the equipment and the waste container. To avoid static sparking and injury from splashing, always flush at the lowest possible pressure.

NOTE: The pump is tested with lightweight oil, which is left in to protect the pump parts. If the fluid you are using may be contaminated by the oil, flush it out with a compatible solvent before using the pump.

Always flush at the lowest pressure possible. Check connectors for leaks and tighten as necessary. Flush with a fluid that is compatible with the fluid being dispensed and the equipment wetted parts.





NOTE: Check with your fluid manufacturer or supplier for recommended flushing fluids and flushing frequency.

NOTICE
<p>To prevent damage to the pump from rust, never leave water or water-based fluid in a carbon steel pump overnight. If you are pumping a water-based fluid, flush with water first. Then flush with a rust inhibitor, such as mineral spirits. Relieve pressure, but leave the rust inhibitor in the pump to protect parts from corrosion.</p>

NOTE: Refer to the E-Flo SP Software Instructions manual for information about using the software features of the ADM. See **Related Manuals** on page 2.

1. Follow the **Pressure Relief Procedure** on page 16.
2. Turn the disconnect switch (J) ON.
3. At the ADM (D), use the ADM's arrow keys to select the pump you want to flush from the Menu Bar.

NOTE: If multiple pumps are connected together, there can be up to six pumps shown in the Menu Bar.

4. Enter the Edit screen for that pump by pressing the soft key next to the  icon.
5. Press the soft key next to the Pressure Mode  icon.
6. Enter 100 psi (0.69 MPa, 6.9 bar) as the pressure.
7. Press the soft key next to the Pump On/Off  icon to turn on the pump.
8. Adjust pressure as necessary.
9. Hold a metal part of the dispense valve firmly to the side of a grounded metal pail.
10. Open the dispense valve and flush the system until clear solvent flows from the gun/valve.
11. Exit the Edit screen by pressing the soft key next to the  icon.
12. If you have multiple pumps connected, repeat steps 3 through 11 for each pump you want to flush.

Follow the **Pressure Relief Procedure** on page **16**.

Pressure Relief Procedure

 Follow the Pressure Relief Procedure whenever you see this symbol.

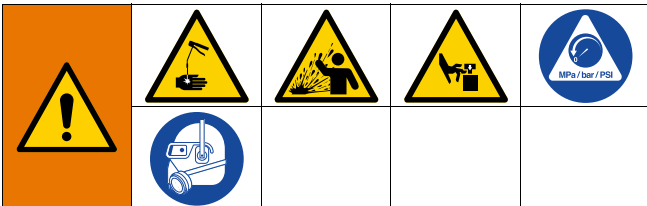



This equipment stays pressurized until pressure is manually relieved. To help prevent serious injury from pressurized fluid, such as skin injection, splashing fluid and moving parts, follow the Pressure Relief Procedure when you stop spraying and before cleaning, checking, or servicing the equipment.

NOTE: Refer to the E-Flo SP Software Instructions manual for additional information about using the software features of the ADM. See **Related Manuals** on page 2.

1. Make sure the power is turned on.
2. At the ADM (D), use the ADM's arrow keys to select a pump from the Menu Bar.

NOTE: If multiple pumps are connected together, there can be up to six pumps listed in the Menu Bar.

3. Enter the Edit screen for that pump by pressing the soft key next to the  icon.
4. Press the soft key next to the  icon to stop the pump.
5. Hold a metal part of the dispense valve firmly to the side of a grounded metal pail, and open the dispense valve to relieve pressure.
6. Exit the Edit screen for that pump by pressing the soft key next to the  icon.
7. If you are using multiple pumps connected, repeat steps 2 through 6 for each pump showing in the ADM's Menu Bar.
8. Turn the disconnect switch (J) OFF.

9. Open your system's fluid line drain valve and open each pumps bleed valve (G). Have a container ready to catch the drainage.
10. Leave the pump bleed valves (G) open until ready to dispense again.

Shutdown and Care of the Pump



NOTICE

To prevent damage to the pump from rust, never leave water or water-based fluid in a carbon steel pump overnight. If you are pumping a water-based fluid, flush with water first. Then flush with a rust inhibitor, such as mineral spirits. Relieve pressure, but leave the rust inhibitor in the pump to protect parts from corrosion.

1. Stop each pump at the bottom of the stroke to prevent fluid from drying on the exposed displacement rod and damaging the throat packings. See the E-Flo SP Software Instructions manual for information about jogging the pump. See **Related Manuals** on page 2.
2. Always flush each pump before the fluid dries on the displacement rod. Follow the flushing the pump procedure in **Flush the Pump** on page 14.

Driver Maintenance



NOTICE

Do not open/remove the gear cover. Opening the gear cover may alter the factory set bearing pre-load and may reduce the product life.

Preventative Maintenance Schedule

The operating conditions of your particular system determine how often maintenance is required. Establish a preventative maintenance schedule by recording when and what kind of maintenance is needed, and then determine a regular schedule for checking your system.

Change the Oil

NOTE: Change the oil after a break-in period of 200,000 to 300,000 cycles. After the break-in period, change the oil once per year.

1. Follow the **Pressure Relief Procedure** on page 16.
2. Place a minimum 2 quart (1.9 liter) container under the oil drain port.
3. Remove the oil drain plug. See **Figure 13** for the location of the drain plug. Allow all oil to drain from the driver.
4. Reinstall the oil drain plug. Torque to 18-23 ft-lb (25-30 N•m).
5. Open the fill cap and add Graco Part 16W645 ISO 220 silicone-free synthetic EP gear oil. Check the oil level in the sight glass. Fill until the oil level is near the halfway point of the sight glass. The oil capacity is approximately 1.0 - 1.2 quarts (0.9 - 1.1 liters). **Do not overfill.**
6. Reinstall the fill cap.

Check Oil Level

Refer to **Figure 13** below. Check the oil level in the sight glass on a regular basis. The oil level should be near the halfway point of the sight glass when the driver is not running. If the oil is low, open the fill cap and add Graco Part No. 16W645 ISO 220 silicone-free synthetic EP gear oil.

The oil capacity is approximately 1.0 - 1.2 quarts (0.9 - 1.1 liters). **Do not overfill.**

NOTICE

Only use oil with Graco part number 16W645. Any other oil may not lubricate properly and can cause damage to the drive train.

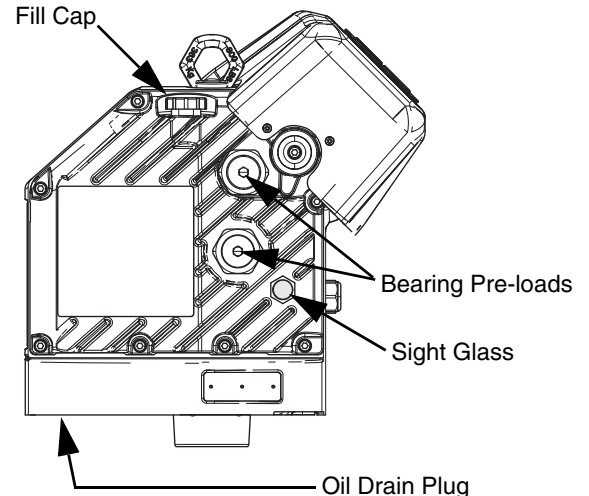

FIG. 13: Sight Glass and Oil Fill Cap

Bearing Pre-Load

The bearing pre-loads are factory set and are not user adjustable. Do not adjust the bearing pre-loads. See the APD20 Driver Instructions-Parts manual for maintenance information. See **Related Manuals** on page 2.

Parts

Electric Pumps with Check-Mate Lower

NOTE: These parts apply to all Check-Mate electric pump configurations.

EC100CS2 Shown

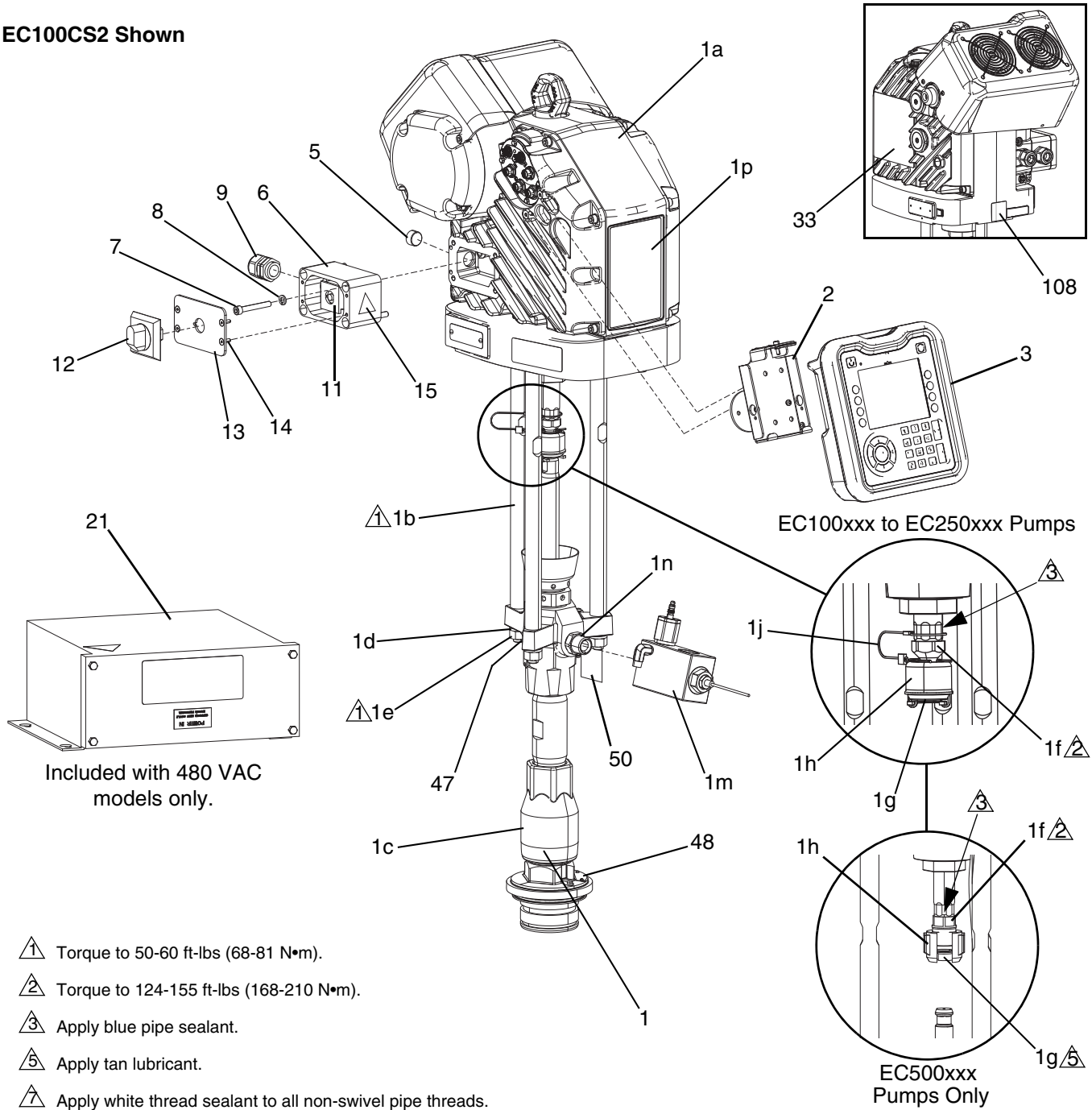

FIG. 14: Check-Mate Electric Pump Parts

Parts List for EC100xxx, 200xxx, and 250xxx

			EC100CSx	EC100CMx	EC100SSx	EC100SMx	EC200CSx	EC200CMx	EC200SSx	EC200SMx	EC250CSx	EC250CMx	EC250SSx	EC250SMx
Ref	Part	Description	Quantity											
1	---	PUMP, electrical, c-mate												
1a	25N519	KIT, driver, apd20, vertical	1	1	1	1	1	1	1	1	1	1	1	1
1b	15K750	ROD, tie, nxt to cm lower	3	3	3	3	3	3	3	3	3	3	3	3
1c	Table 1†	LOWER, pump	1	1	1	1	1	1	1	1	1	1	1	1
1d	108098	WASHER, lock, spring	3	3	3	3	3	3	3	3	3	3	3	3
1e	106166	NUT, mach, hex	3	3	3	3	3	3	3	3	3	3	3	3
1f	15H392	ROD, adapter, extreme	1	1	1	1	1	1	1	1	1	1	1	1
1g	244819	COUPLING, assembly, 145-290 xtreme	1	1	1	1	1	1	1	1	1	1	1	1
1h	197340	COVER, coupler	1	1	1	1	1	1	1	1	1	1	1	1
1j	244820	CLIP, hairpin, (w/ lanyard)	1	1	1	1	1	1	1	1	1	1	1	1
1k	112887*	TOOL, wrench, spanner	1	1	1	1	1	1	1	1	1	1	1	1
1m	25N738	VALVE, check, 1 in. npt with relief	1	1	1	1								
	25N780	VALVE, check, 1 in. npt					1	1	1	1	1	1	1	1
1n	158586	FITTING, bushing	1	1										
	131523	BUSHING, hex hd, 3/4 npt X 1 npt, ss			1	1								
	131526	FITTING, nipple, 1 in. npt, cs					2	2			2	2		
	131524	FITTING, nipple, 1 in. npt, ss							2	2			2	2
1p	17Y515	LABEL, e-flo sp	1	1	1	1	1	1	1	1	1	1	1	1
1r	C38321*	TIE, cable, 3.62 LG	2	2	2	2	2	2	2	2	2	2	2	2
2	24P823✓	MODULE, control, bracket	1	1	1	1	1	1	1	1	1	1	1	1
3	24E451✓	MODULE, gca, adm	1	1	1	1	1	1	1	1	1	1	1	1
4	121001*	CABLE, can, female / female 1.0 m	1	1	1	1	1	1	1	1	1	1	1	1
5	102726	PLUG, pipe headless	1	1	1	1	1	1	1	1	1	1	1	1
6	17X387	BOX, junction, power, motor, apd	1	1	1	1	1	1	1	1	1	1	1	1
7	117080	SCREW, Shcs m8 x 60	4	4	4	4	4	4	4	4	4	4	4	4
8	104572	WASHER, lock spring	4	4	4	4	4	4	4	4	4	4	4	4
9	121171	GRIP, cord, .35-.63, 3/4	1	1	1	1	1	1	1	1	1	1	1	1
10	123407*	FERRULE, wire, 16 awg	2	2	2	2	2	2	2	2	2	2	2	2
11	123970	SWITCH, disconnect, 40 a	1	1	1	1	1	1	1	1	1	1	1	1
12	123971	KNOB, disconnect, operator	1	1	1	1	1	1	1	1	1	1	1	1
13	130692	COVER, junction box, apd motor	1	1	1	1	1	1	1	1	1	1	1	1
14	113768	SCREW, socket, fl hd	4	4	4	4	4	4	4	4	4	4	4	4
15	16T764▲	LABEL, warning	1	1	1	1	1	1	1	1	1	1	1	1
21	25E268‡	KIT, transformer, stand alone	1	1	1	1	1	1	1	1	1	1	1	1

			EC100CSx	EC100CMx	EC100SSx	EC100SMx	EC200CSx	EC200CMx	EC200SSx	EC200SMx	EC250CSx	EC250CMx	EC250SSx	EC250SMx
Ref	Part	Description	Quantity											
Electric Driver Warning Labels														
33	16W360▲◆	LABEL, safety, warning, multiple	1	1	1	1	1	1	1	1	1	1	1	1
	17J476▲❖	LABEL, safety, warning, multiple	1	1	1	1	1	1	1	1	1	1	1	1
108	195792▲◆	LABEL, safety, warning, electric shock	1	1	1	1	1	1	1	1	1	1	1	1
	195793▲❖	LABEL, safety, warning, electric shock	1	1	1	1	1	1	1	1	1	1	1	1
Pump Lower Warning Labels														
47	184090▲	PLATE, warning	1	1	1	1	1	1			1	1		
	184462▲	PLATE, warning, sst							1	1			1	1
48	184151▲	LABEL, warning	1	1	1	1								
50	172479▲	TAG, warning	1	1	1	1	1	1	1	1	1	1	1	1

--- Not available for individual sale.

* Not shown.

† Refer to **Table 1** below for the part number for each model.

✓ Only available on models with an ADM - model numbers ending in a 2 or 4. See **Models** on page 3.

‡ Only available on models with 480 VAC power - model numbers ending in a 3 or 4. See **Models** on page 3.

▲ Replacement Danger and Warning labels, tags, and cards are available at no cost.

◆ English, Japanese, Korean, and Chinese.

❖ English, Spanish, French.

Table 1: Check-Mate Pump Lower - Ref 3

Pump Model	Part	Pump Model	Part
EC100CSx	L100CS	EC250CSx	L250CS
EC100CMx	L100CM	EC250CMx	L250CM
EC100SSx	L100SS	EC250SSx	L250SS
EC100SMx	L100SM	EC250SMx	L250SM
EC200CSx	L200CS	EC500CSx	L500CS
EC200CMx	L200CM	EC500CMx	L500CM
EC200SSx	L200SS	EC500SSx	L500SS
EC200SMx	L200SM	EC500SMx	L500SM

Parts List for EC500xxx

			EC500CSx	EC500CMx	EC500SSx	EC500SMx
Ref	Part	Description	Quantity			
1	---	PUMP, electric, c-mate, 500cc	1	1	1	1
1a	25N519	KIT, driver, apd20, vertical	1	1	1	1
1b	15K750	ROD, tie, nxt to cm lower	3	3	3	3
1c	Table 1†	LOWER, pump	1	1	1	1
1d	108098	WASHER, lock, spring	3	3	3	3
1e	106166	NUT, mach, hex	3	3	3	3
1f	15H370	ADAPTER, 1 1/4-12	1	1	1	1

			EC500CSx	EC500CMx	EC500SSx	EC500SMx
Ref	Part	Description	Quantity			
1g	184129	COLLAR, coupling	1	1	1	1
1h	186925	NUT, coupling	1	1	1	1
1k	112887*	TOOL, wrench, spanner	1	1	1	1
1m	25N739	VALVE, check, 1 1/2 in. npt	1	1	1	1
1p	17Y515	LABEL, e-flo sp	1	1	1	1
1r	C38321*	TIE, cable, 3.62 LG	2	2	2	2
2	24P823✓	MODULE, control, bracket	1	1	1	1
3	24E451✓	MODULE, gca, adm	1	1	1	1
4	121001*	CABLE, can, female / female 1.0 m	1	1	1	1
5	102726	PLUG, pipe headless	1	1	1	1
6	17X387	BOX, junction, power, motor, apd	1	1	1	1
7	117080	SCREW, Shcs m8 x 60	4	4	4	4
8	104572	WASHER, lock spring	4	4	4	4
9	121171	GRIP, cord, .35-.63, 3/4	1	1	1	1
10	123407*	FERRULE, wire, 16 awg	2	2	2	2
11	123970	SWITCH, disconnect, 40 a	1	1	1	1
12	123971	KNOB, disconnect, operator	1	1	1	1
13	130692	COVER, junction box, apd motor	1	1	1	1
14	113768	SCREW, socket, fl hd	4	4	4	4
15	16T764▲	LABEL, warning	1	1	1	1
21	25E268‡	KIT, transformer, stand alone	1	1	1	1
Electric Driver Warning Labels						
33	16W360▲◆	LABEL, safety, warning, multiple	1	1	1	1
	17J476▲❖	LABEL, safety, warning, multiple	1	1	1	1
108	195792▲◆	LABEL, safety, warning, electric shock	1	1	1	1
	195793▲❖	LABEL, safety, warning, electric shock	1	1	1	1
Pump Lower Warning Labels						
47	184090▲	PLATE, warning	1	1		
	184462▲	PLATE, warning, sst			1	1
48	184293▲	PLATE, warning	1	1	1	1
50	172479▲	TAG, warning	1	1	1	1

--- Not available for individual sale.

* Not shown.

‡ Refer to **Table 1** on page **20** for the part number for each model.

✓ Only available on models with an ADM - model numbers ending in a 2 or 4. See **Models** on page **3**.

‡ Only available on models with 480 VAC power - model numbers ending in a 3 or 4. See **Models** on page **3**.

▲ Replacement Danger and Warning labels, tags, and cards are available at no cost.

◆ English, Japanese, Korean, and Chinese.

❖ English, Spanish, French.

Electric Pumps with Dura-Flo Lower

NOTE: These parts apply to all Dura-Flo electric pump configurations.

ED115CS2 Shown

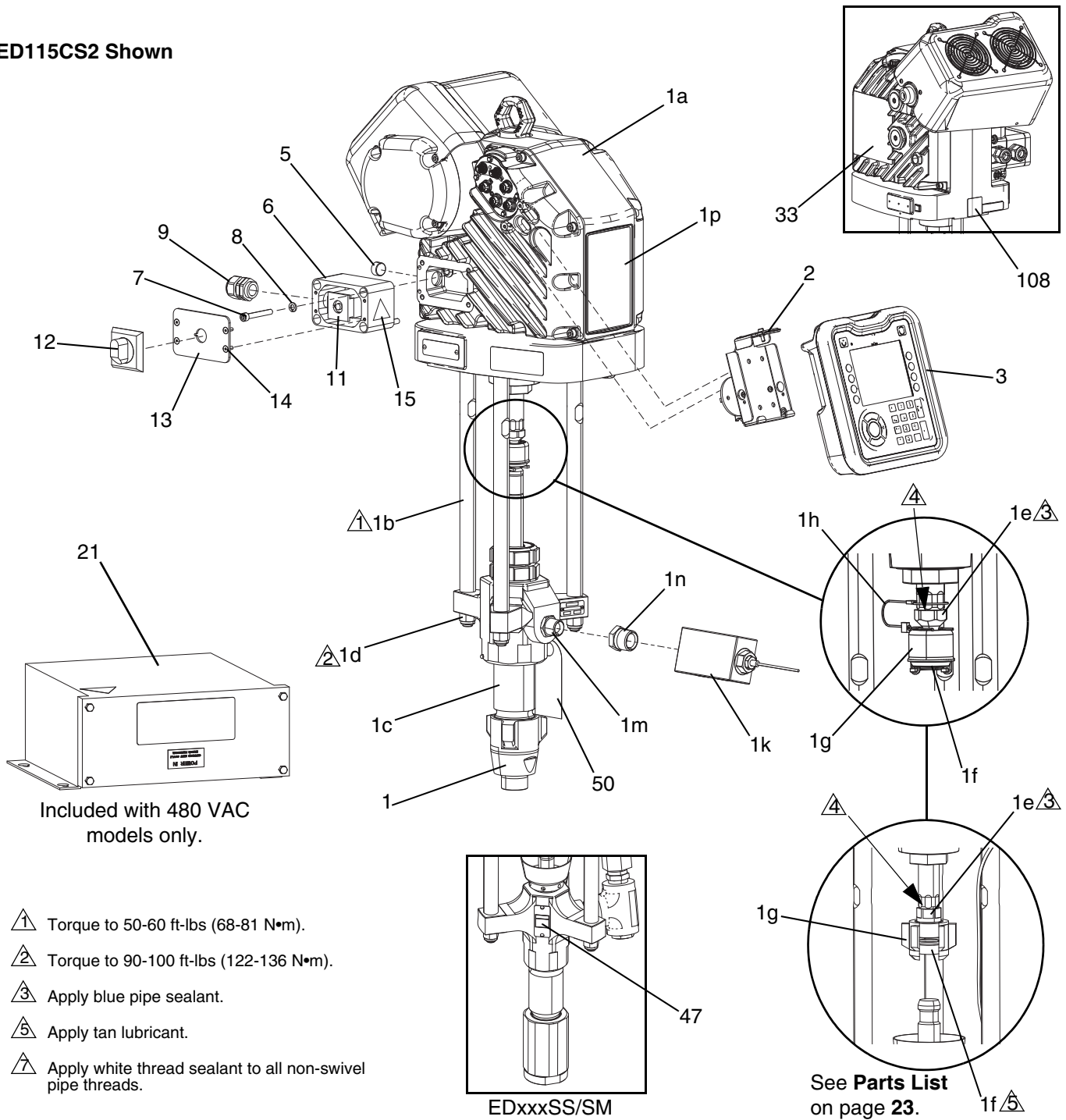

FIG. 15: Dura-Flo Electric Pump Parts

Parts List for All EPDxxxxxx Models

			ED115CSX	ED145CSX	ED145SSX	ED180CSX	ED180SSX	ED220CSX	ED220SSX	ED290CSX	ED290SSX	ED430CSX	ED430SSX	ED430SMX
Ref	Part	Description	Quantity											
1	---	PUMP, electrical, duraflo												
1a	25N519	KIT, driver, apd20, vertical	1	1	1	1	1	1	1	1	1	1	1	1
1b	15F837	ROD, tie, 14 1/4 long	3	3		3		3		3				
	15H562	ROD, tie			3		3		3		3	3	3	3
1c	Table 4†	LOWER, xtreme, 115, nf, xseal	1	1	1	1	1	1	1	1	1	1	1	1
1d	101712	NUT, lock	3	3	3	3	3	3	3	3	3	3	3	3
1e	15H392	ROD, adapter xtreme	1	1		1		1		1				
	15H370	ADAPTER, 1 1/4-12			1		1		1		1			
	15H371	ADAPTER, m38 x 2										1	1	1
1f	247167	COUPLING, assembly, 36-115 xtreme	1											
	244819	COUPLING, assembly, 145-290 xtreme		1		1		1		1				
	184129	COLLAR, coupling			2		2		2		2			
	184130	COLLAR, coupling										2	2	2
1g	197340	COVER, coupler	1	1		1		1		1				
	186925	NUT, coupling			1		1		1		1			
	184096	NUT, coupling										1	1	1
1h	244820	CLIP, hairpin (w/ lanyard)	1	1		1		1		1				
1j	112887*	TOOL, wrench, spanner			1		1		1		1			
	184278*	TOOL, wrench, combo										1	1	1
1k	25N780	VALVE, check, 1 in. npt	1	1	1	1	1	1	1	1	1			
	25N739	VALVE, check, 1 1/2 in. npt										1	1	1
1m	157191	FITTING, adapter, 1/2 npt x 3/4 npt	1											
	C38304	FITTING, nipple, 1 X 3/4 npt		1		1								
	131525	FITTING, nipple, reducing, ss			1		1							
	131526	FITTING, nipple, 1 in. npt, cs						1		2				
	131524	FITTING, nipple, 1 in. npt, ss							2		2			
1n	158586	FITTING, bushing, 3/4 x 1 npt	1											
1p	17Y515	LABEL, e-flo sp	1	1	1	1	1	1	1	1	1	1	1	1
1r	C38321*	TIE, cable, 3.62 LG	2	2	2	2	2	2	2	2	2	2	2	2
2	24P823✓	MODULE, control, bracket	1	1	1	1	1	1	1	1	1	1	1	1
3	24E451✓	MODULE, gca, adm	1	1	1	1	1	1	1	1	1	1	1	1
4	121001*	CABLE, can, female / female 1.0 m	1	1	1	1	1	1	1	1	1	1	1	1
5	102726	PLUG, pipe headless	1	1	1	1	1	1	1	1	1	1	1	1
6	17X387	BOX, junction, power, motor, apd	1	1	1	1	1	1	1	1	1	1	1	1
7	117080	SCREW, Shcs m8 x 60	4	4	4	4	4	4	4	4	4	4	4	4
8	104572	WASHER, lock spring	4	4	4	4	4	4	4	4	4	4	4	4
9	121171	GRIP, cord, .35-.63, 3/4	1	1	1	1	1	1	1	1	1	1	1	1
10	123407*	FERRULE, wire, 16 awg	2	2	2	2	2	2	2	2	2	2	2	2

			ED115CSx	ED145CSx	ED145SSx	ED180CSx	ED180SSx	ED220CSx	ED220SSx	ED290CSx	ED290SSx	ED430CSx	ED430SSx	ED430SMx
Ref	Part	Description	Quantity											
11	123970	SWITCH, disconnect, 40 a	1	1	1	1	1	1	1	1	1	1	1	1
12	123971	KNOB, disconnect, operator	1	1	1	1	1	1	1	1	1	1	1	1
13	130692	COVER, junction box, apd motor	1	1	1	1	1	1	1	1	1	1	1	1
14	113768	SCREW, socket, fl hd	4	4	4	4	4	4	4	4	4	4	4	4
15	16T764▲	LABEL, warning	1	1	1	1	1	1	1	1	1	1	1	1
21	25E268‡	KIT, transformer, stand alone	1	1	1	1	1	1	1	1	1	1	1	1
Electric Driver Warning Labels														
33	16W360▲◆	LABEL, safety, warning, multiple	1	1	1	1	1	1	1	1	1	1	1	1
	17J476▲❖	LABEL, safety, warning, multiple	1	1	1	1	1	1	1	1	1	1	1	1
108	195792▲◆	LABEL, safety, warning, electric shock	1	1	1	1	1	1	1	1	1	1	1	1
	195793▲❖	LABEL, safety, warning, electric shock	1	1	1	1	1	1	1	1	1	1	1	1
Pump Lower Warning Label														
47	184474▲	PLATE, warning, sst			1		1		1		1		1	1
50	172479▲	TAG, Warning	1	1	1	1	1	1	1	1	1	1	1	1

--- Not available for individual sale.

* Not shown.

† Refer to **Table 2** below for the part number for each model.

✓ Only available on models with an ADM - model numbers ending in a 2 or 4. See **Models** on page 3.

‡ Only available on models with 480 VAC power - model numbers ending in a 3 or 4. See **Models** on page 3.

▲ Replacement Danger and Warning labels, tags, and cards are available at no cost.

◆ English, Japanese, Korean, and Chinese.

❖ English, Spanish, French.

Pump Model	Part		Pump Model	Part
ED115CSx	L115C1		ED220SSx	L220SS
ED145CSx	L14AC1		ED290CSx	L290C1
ED145SSx	L145SS		ED290SSx	L290SS
ED180CSx	L180C1		ED430CSx	L430CS
ED180SSx	L180SS		ED430SSx	L430SS
ED220CSx	L220C1		ED430SMx	L430SM

Check Valves

Check Valve Block with Pressure Relief, 25N738

NOTE: For model EC100xxx only.

- △₂ Apply a light coating of anti-seize lubricant as needed.
- △₃ Torque to 30 +/- 2 ft-lbs (41 +/- 2 N•m).
- △₄ Apply blue sealant to threads as needed.
- △₆ Apply grease.

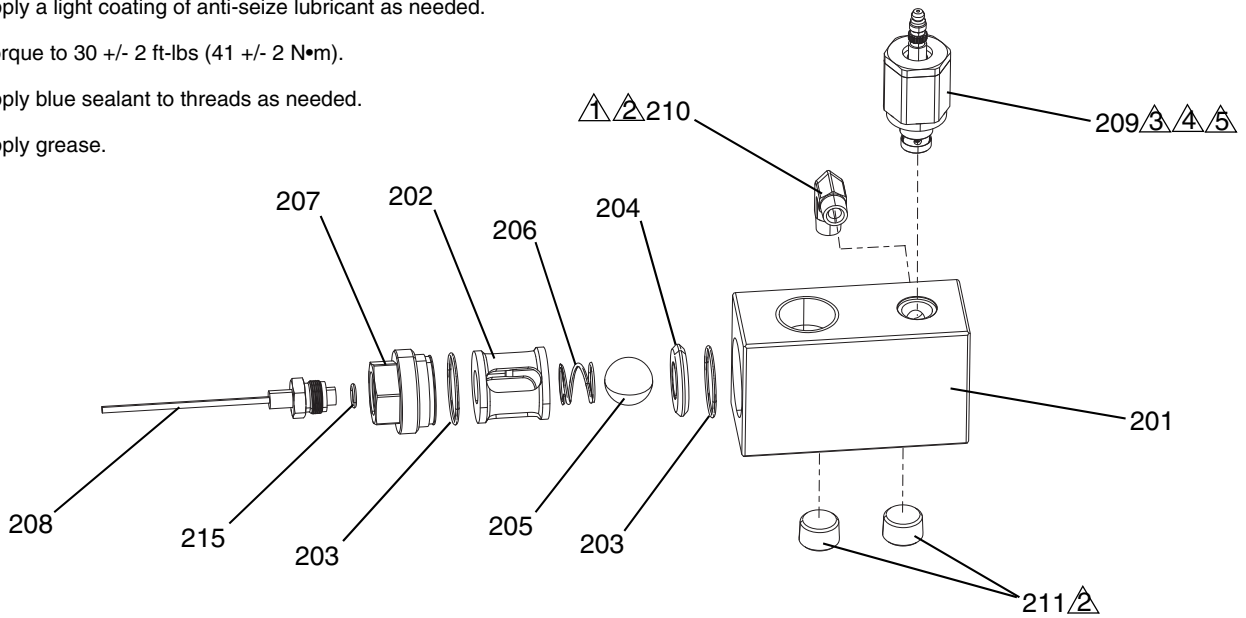

FIG. 16: Check Valve with Pressure Relief

Ref	Part	Description	Qty
201	19A565	BLOCK, check valve, 1 in. npt sst	1
202	15Y168	HOUSING, ball cage	1
203	107098*	PACKING, o-ring	2
204	193395*	SEAT, carbide	1
205	107167*	BALL, sst, 1 in.	1
206	258784*	SPRING, ball check	1
207	19A567	CAP, check valve, 1 in. npt sst	1
208	15M669	SENSOR, pressure, fluid outlet	1
209	262520	KIT, valve, relief, silver, xp70	1
210	166866	FITTING, elbow	1
211	103778	PLUG, pipe, hdls	2
215	111457	PACKING, o-ring	1

* Parts are available in Repair Kit 25E718.

Check Valve Block, 1-1/2 Inch, 25N739

NOTE: For models EC500xxx and ED430xxx

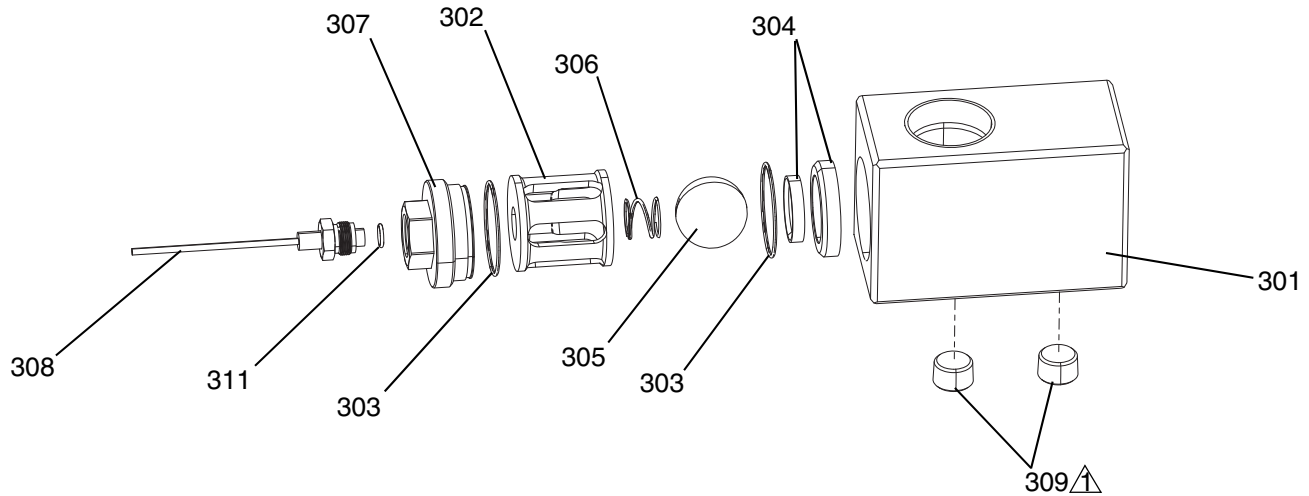

 Apply a light coating of anti-seize lubricant as needed.

FIG. 17: 1-1/2 Inch Check Valve

Ref	Part	Description	Qty
301	19A566	BLOCK, check valve, 1-12 in. npt sst	1
302	17Y980	HOUSING, ball cage 1-1/2 in. npt check	1
303	104537*	PACKING, o-ring	2
304	25N740*	BALL, seat, assy 1-1/2 in. npt, check	1
305	109220*	BALL, metallic	1
306	258784*	SPRING, ball check	1
307	19A568	CAP, check valve, 1-1/2 in. npt sst	1
308	15M669	SENSOR, pressure, fluid outlet	1
309	103778	PLUG, pipe, hdls	2
311	111457	PACKING, o-ring	1

* Parts are available in Repair Kit 25E719.

Check Valve Block, 1 Inch, 25N780

NOTE: For models EC200xxx, EC250xxx, ED115xxx, ED145xxx, ED180xxx, ED220xxx, ED290xxx

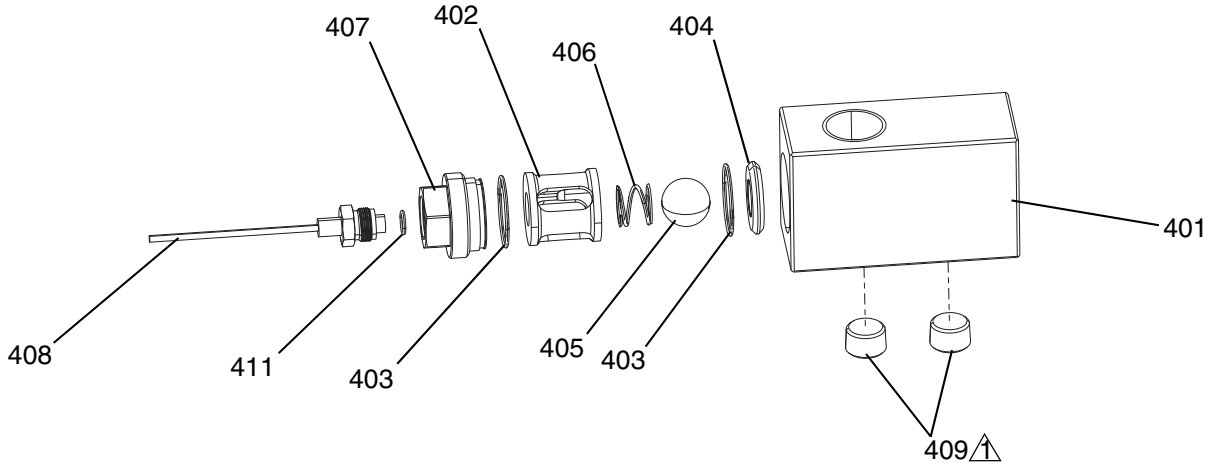

 Apply a light coating of anti-seize lubricant as needed.

FIG. 18: 1 Inch Check Valve

Ref	Part	Description	Qty
401	19A615	BLOCK, check valve, 1 in. npt sst	1
402	15Y168	HOUSING, ball cage	1
403	107098*	PACKING, o-ring	2
404	193395*	SEAT, carbide	1
405	107167*	BALL, sst, 1 in.	1
406	258784*	SPRING, ball check	1
407	19A568	CAP, check valve, 1-1/2 in. npt sst	1
408	15M669	SENSOR, pressure, fluid outlet	1
409	103778	PLUG, pipe, hdls	2
411	111457	PACKING, o-ring	1

* Parts are available in Repair Kit 25E718.

Kits and Accessories

Advanced Display Module Kit 25E439

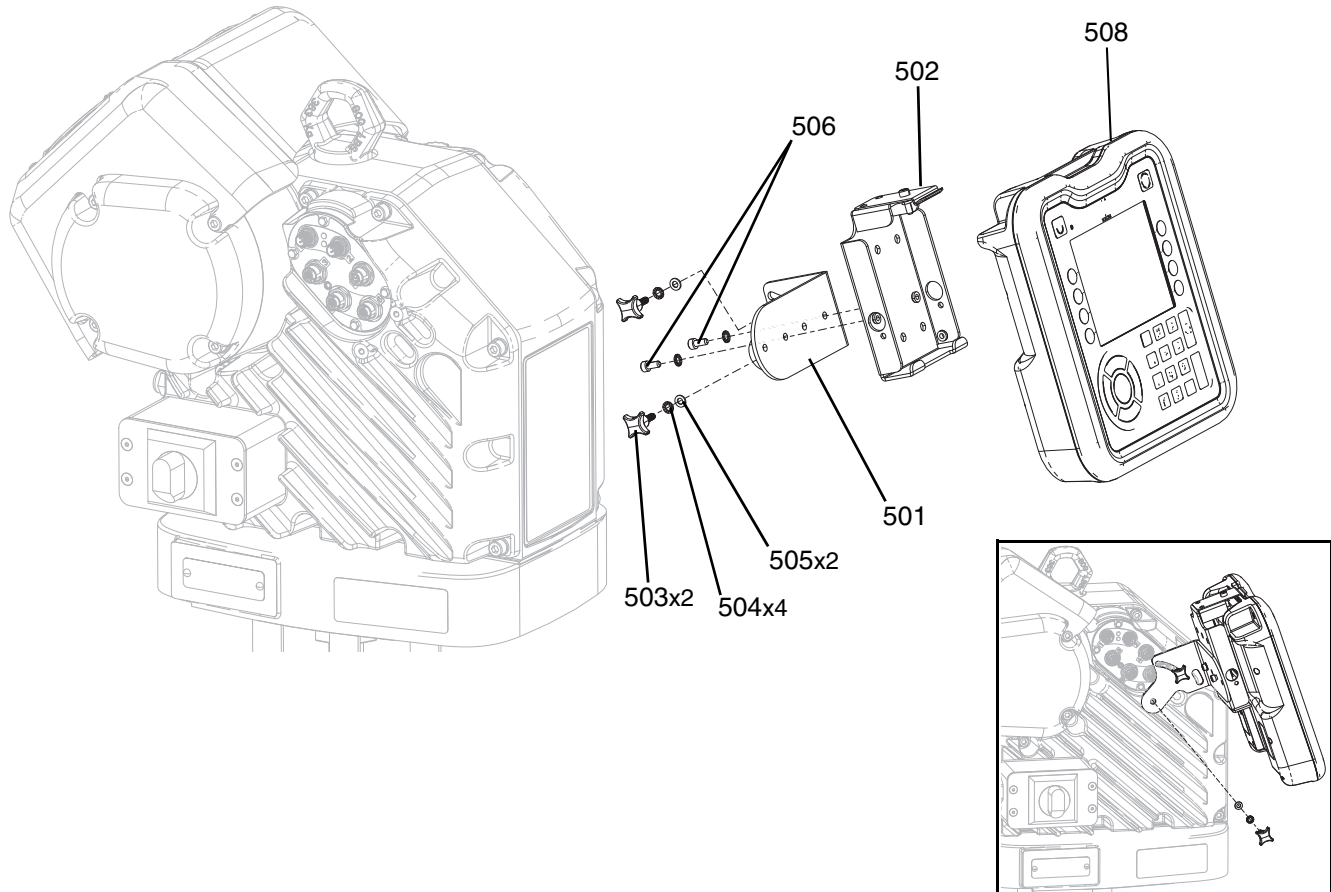

FIG. 19: ADM Kit

Ref	Part	Description	Qty
501	16T234	BRACKET, display, mount	1
502	24A326	BRACKET, mounting, assembly	1
503	16T935	FASTENER, knob	2
504	111307	WASHER, lock, external	4
505	117017	WASHER	2
506	117026	SCREW, shcs m5 x 12	2
507	121001*	CABLE, can, female/female 1.0 m	1
508	24E451	MODULE, gca, adm	1

* Not shown.

NOTE: Attach the ADM kit as shown in **Figure 19**.

Communication Gateway Module (CGM) Kits

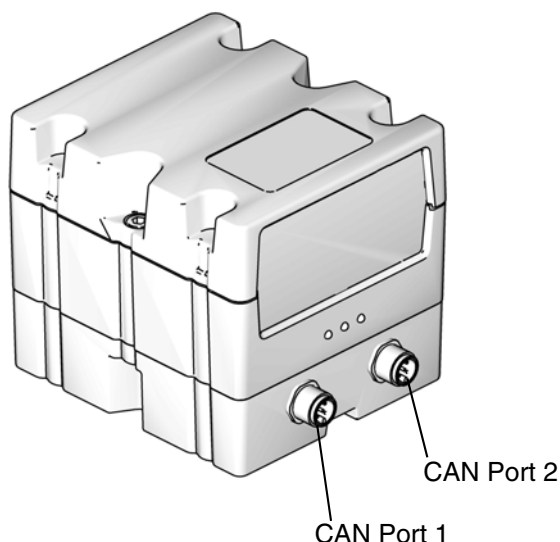

FIG. 20: CGM CAN Connections

CGM Kits

Part Number	Description
25E426	CGM Kit, Ethernetip
25E427	CGM Kit, DeviceNet
25E428	CGM Kit, PROFINET
25E429	CGM Kit, PROFIBUS

Installing a CGM Kit

All electrical wiring must be done by a qualified electrician and comply with all local codes and regulations

1. Follow the **Pressure Relief Procedure** on page 16.
2. Verify the power is off to the system.
3. Mount the CGM near the pump or near the integration point.

4. Drill the mounting holes using the mounting hole dimensions shown in **Figure 21**.

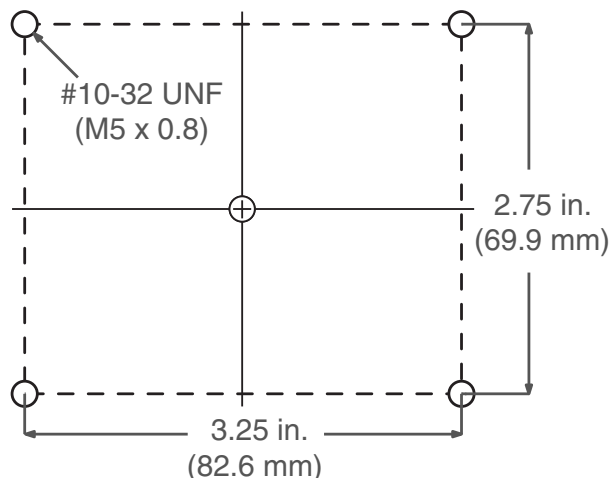

FIG. 21: CGM Mounting Holes

5. Remove the access cover from the CGM (U). Loosen the two screws (T) and remove the CGM (R) from the base (S) as shown in **Figure 22**.

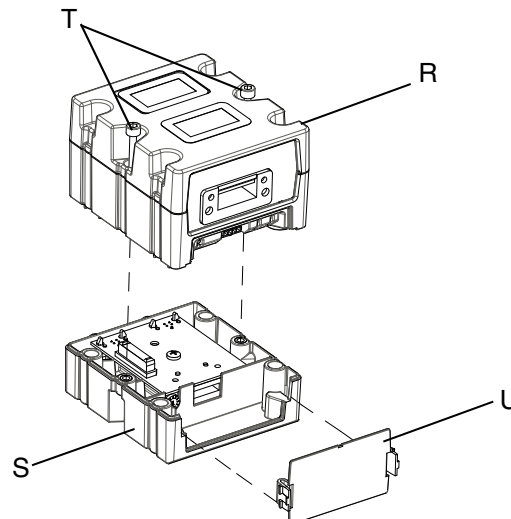

FIG. 22: Disassembling the CGM

6. Using the four 10-32 mounting screws included with the kit, mount the base (S) in the holes you drilled.
7. Reattach the CGM (R) on the base (S) with the two screws (T) that were removed in step 5.
8. Reattach the access cover (U).

- Connect the CAN cable included in the kit to either port 1 or port 2 (whichever is available) on the driver. See **Figure 23**.

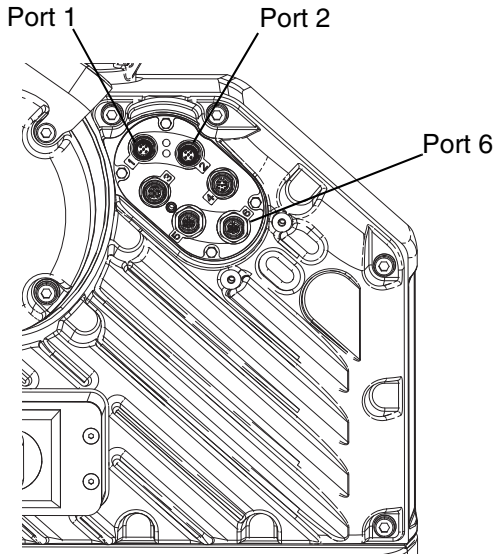

Fig. 23: Driver Port Locations

- Connect the other end of the CAN cable to either CAN port 1 or 2 on the CGM. See **Figure 20**. It can be connected to either port.

NOTE: Longer CAN cables, if required, are available from Graco. See **CAN cables** on page 32.

- Connect the Ethernet, DeviceNet, or PROFIBUS cable to the fieldbus connection on the CGM as applicable. See **Figure 24**.

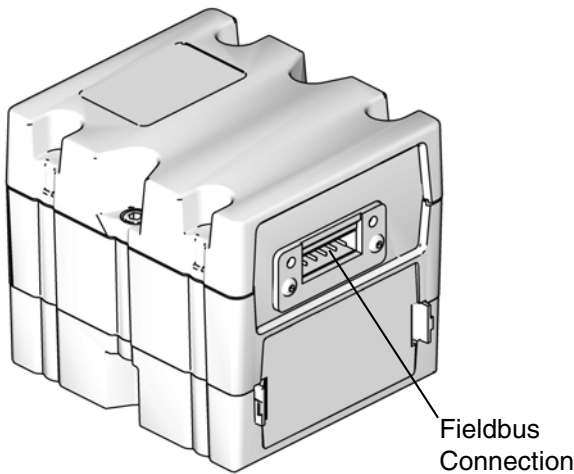

Fig. 24: CGM Fieldbus Connection

- Connect the other end of the cable to the fieldbus device.
- Refer to the Graco Control Architecture Module Programming manual for step-by-step instructions on how to update the software version of GCA modules. See **Related Manuals** on page 2.
- Refer to the E-Flo SP Software Instructions manual for details regarding the fieldbus pinout setup and to perform the setup procedure to configure the fieldbus. See **Related Manuals** on page 2.

Inlet Pressure Sensor Kit, 24Y245

Part	Description	Qty
16U440	ADAPTER, fitting, pressure sensor	1
15M669	SENSOR, pressure, fluid outlet	1
119348	PACKING, o-ring	1

Attach the 5-pin connector to port 6 on the driver. Insert the o-ring over the other end and connect the adapter fitting. Attach the assembled pressure sensor to the fluid input stream based on the configuration of your system.

Pump Stand Frame, 253692

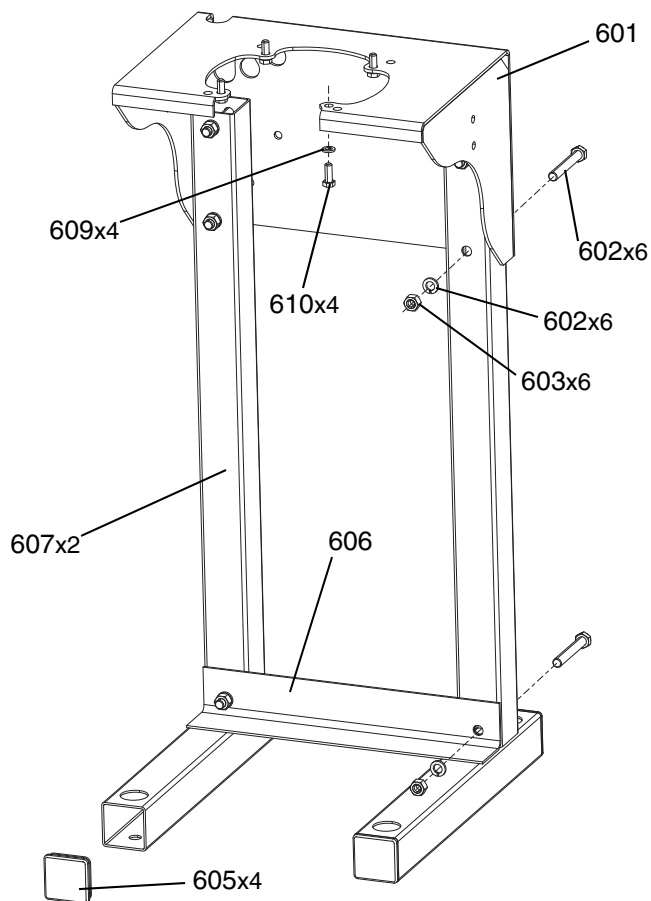

FIG. 25: Pump Stand

Ref	Part	Description	Qty
601	253679	BRACKET, mounted, painted	1
602	100679	SCREW, cap hex hd	6
603	100018	WASHER, lock, spring	6
604	100321	NUT	6
605	120486	CAP, plug	4
606	15H893	FRAME, brace	1
607	253691	FRAME, leg	2
609	100133	WASHER, lock	4
610	100101	SCREW, cap, hex hd	4

1. Assemble the stand as shown in **Figure 25**.
2. Position the pump stand frame so all components of the system are easily accessible when the driver and pump are installed.

3. Refer to the **Pump Stand Mounting Hole Diagram** on page **34** and use the holes in the base of the stand as a guide to drill holes for 1/2 in. (13 mm) anchors.
4. Ensure the stand is level. If necessary, level the base using metal shims. Secure the stand to the floor using four 1/2 in. (13 mm) anchors that are long enough to prevent the stand from tipping.
5. Use the screws and washers supplied with the pump stand frame and refer to the **Electric Driver Mounting Hole Pattern** on page **35** to mount the driver to the stand once the stand is assembled and secured.

Wall Mount Bracket, 255143

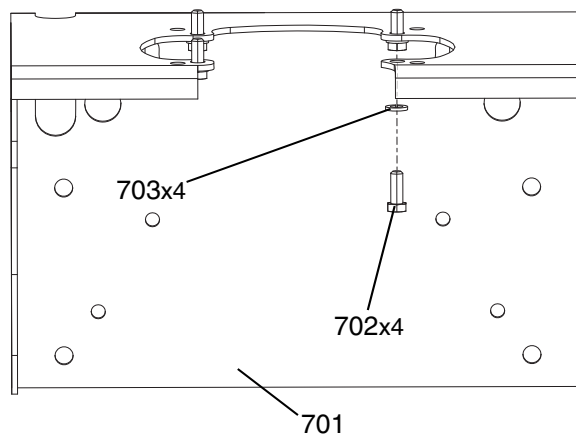

FIG. 26: Wall Mount Bracket

Ref	Part	Description	Qty
701	253679	BRACKET, mounted, painted	1
702	100133	WASHER, lock	4
703	100101	SCREW, cap, hex hd	4

1. Position the wall mount bracket so all components of the system are easily accessible and a sufficient height above the floor. Refer to **Dimensions** on page **33**.

NOTE: Be sure to select a solid position on a wall. Use appropriate sized bolts to support the weight of the pump and driver and any additional weight of the fluid used in the pump. See **Technical Specifications** on page **38** to find the weight of the model you are using.

2. Ensure the wall mount is level using the wall bracket as a template. Drill four 7/16 in (11 mm) diameter holes for the mounting bolts. See **Figure 27** for the mounting hole fastener locations.
3. Bolt the bracket securely to the wall.

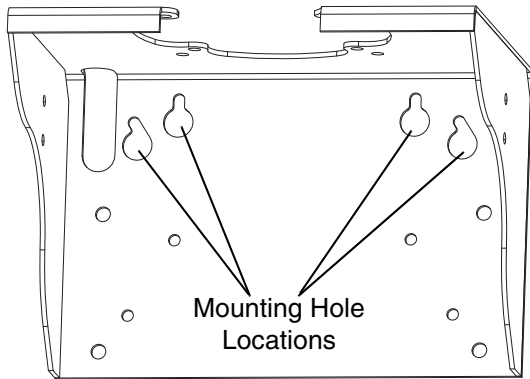

Fig. 27: Wall Mount Hole Locations

4. Use the screws and washers supplied with the wall mount and refer to the **Electric Driver Mounting Hole Pattern** on page 35 to mount the driver to the bracket once it is secured to the wall.

Floor Mount Adapter, 223952

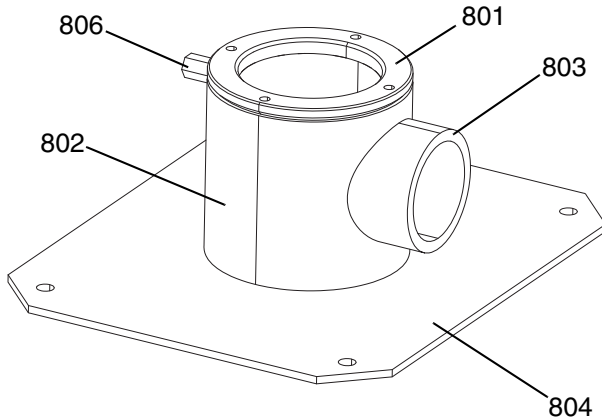

Fig. 28: Floor Mount Stand

Ref	Part	Description	Qty
801	186562	PLATE, mounting inductor	1
802	186560	TUBE, adapter	1
803	186561	COUPLING, pipe	1
804	166538	PLATE, base	1
806	185542	COUPLING, half	1

Refer to the **Floor Stand Mounting Hole Diagram** on page 35 and the Floor Stand Accessory manual for proper installation of this floor mount adapter. See **Related Manuals** on page 2.

CAN Cables

The following CAN cables and splitter are available for use with E-Flow SP electric pumps.

Part	Description	Length
125306	CABLE, CAN, female/female	0.3 m
123422	CABLE, CAN, female/female	0.5 m
121000	CABLE, CAN, female/female	0.5 m
121227	CABLE, CAN, female/female	0.6 m
121001	CABLE, CAN, female/female	1.0 m
121002	CABLE, CAN, female/female	1.5 m
121003	CABLE, CAN, female/female	3.0 m
120952	CABLE, CAN, female/female	4.0 m
121201	CABLE, CAN, female/female	6.0 m
121004	CABLE, CAN, female/female	8.0 m
121228	CABLE, CAN, female/female	15.0 m
123341	CABLE, CAN, female/female	40.0 m
121807	CONNECTOR, splitter, male/male	

Dimensions

E-Flo SP Pump Dimensions

25E325 Shown

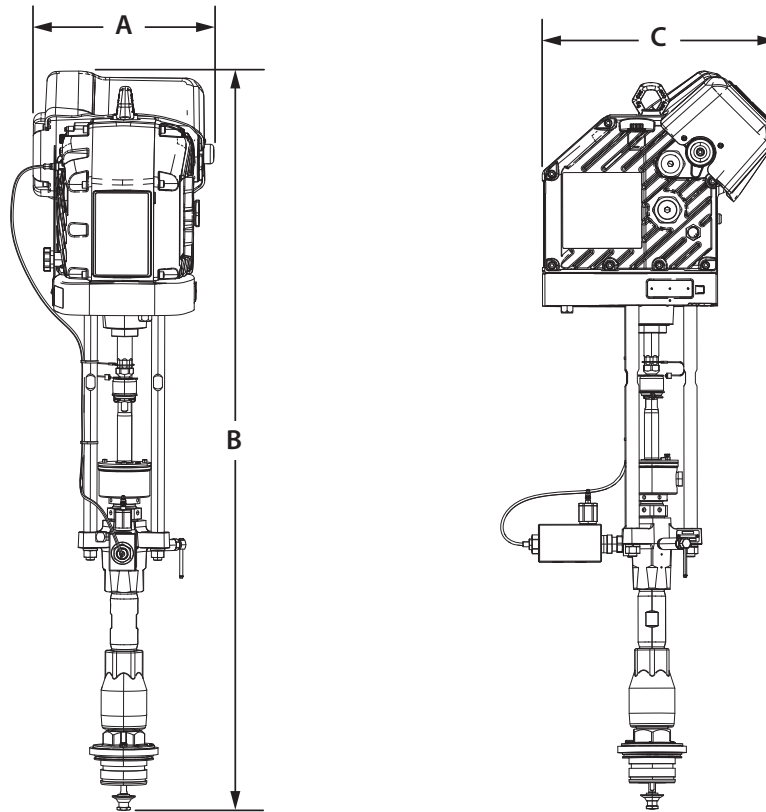

FIG. 29: 220 cc Dura-Flo CS Pump System Dimensions

Pump Description	A		B		C	
	in.	mm	in.	mm	in.	mm
100cc Check-Mate - All	13.7	347.9	54.0	1371.6	19.7	500.3
200cc Check-Mate - All			54.6	1386.8		
250cc Check-Mate - All			54.6	1386.8		
500cc Check-Mate - All			54.2	1376.6		
115cc Dura-Flo CS			44.1	1120.1		
145cc Dura-Flo CS			45.5	1155.7		
145cc Dura-Flo SS			46.5	1181.1		
180cc Dura-Flo CS			44.3	1125.2		
180cc Dura-Flo SS			46.5	1181.1		
220cc Dura-Flo CS			45.0	1143.0		
220cc Dura-Flo SS			47.7	1211.5		
290cc Dura-Flo CS			45.0	1143.0		
290cc Dura-Flo CS			46.6	1183.6		
430cc Dura-Flo - All			48.1	1221.7		

Pump Stand Mounting Hole Diagram

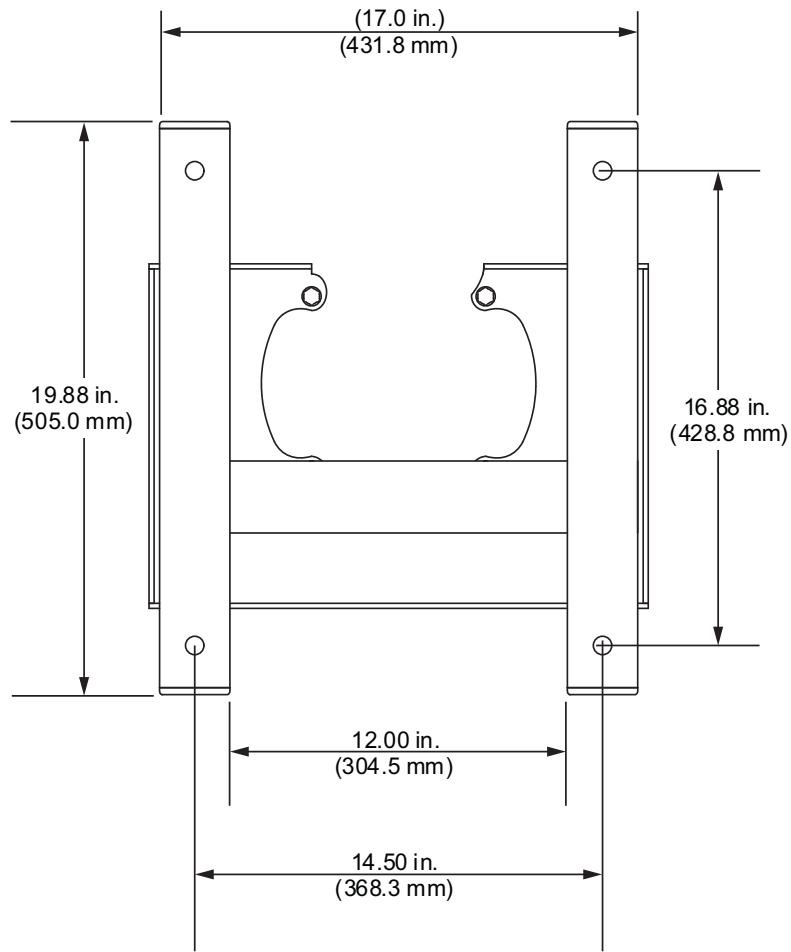

FIG. 30: Pump Stand Mounting Holes

Floor Stand Mounting Hole Diagram

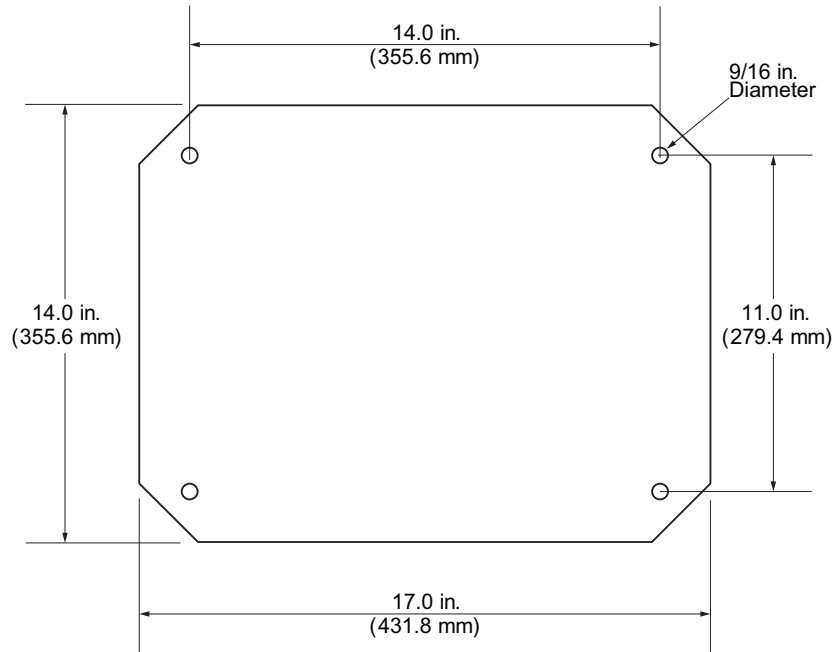

FIG. 31: Floor Stand Mounting Holes

Electric Driver Mounting Hole Pattern

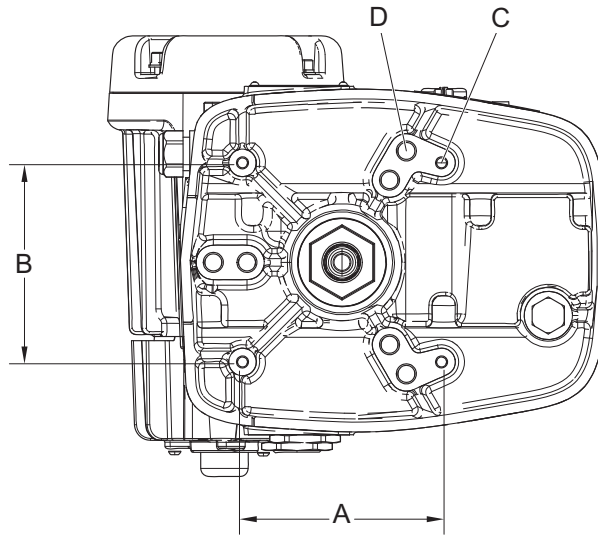

FIG. 32: Electric Driver Mounting Holes

A	B	C	D
6.2 in. (157 mm)	6.2 in. (157 mm)	Four 3/8-16 Mounting Holes	Six 5/8-11 Tie Rod Holes: <ul style="list-style-type: none"> 8 in. (203 mm) x 120° bolt circle OR <ul style="list-style-type: none"> 5.9 in. (150 mm) x 120° bolt circle

Transformer Mounting Hole Diagram

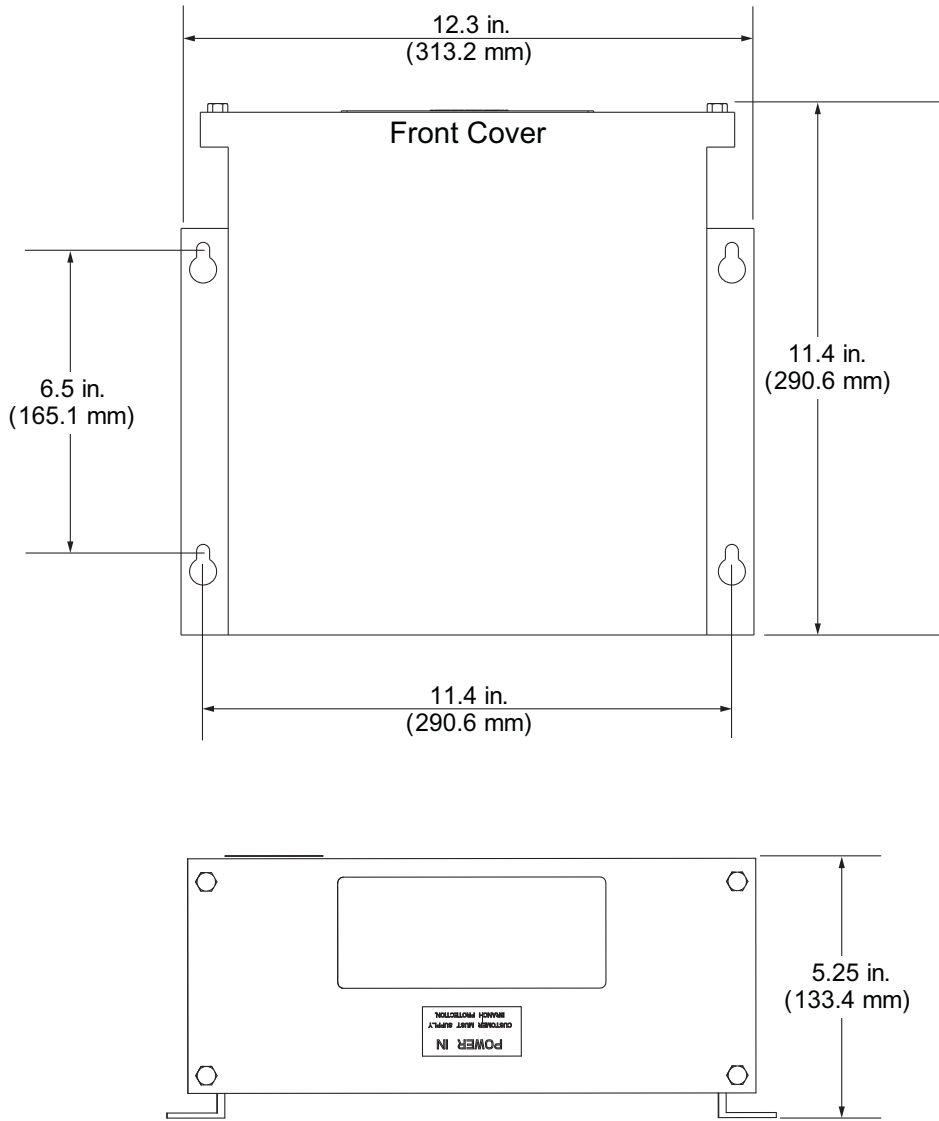

FIG. 33:Transformer Mounting Holes

Pump Performance

Calculate Fluid Outlet Pressure

To calculate fluid outlet pressure (psi/MPa/bar) at a specific fluid flow (gpm/lpm) and electrical power (W), use the following instructions and pump data chart.

1. Refer to the desired flow along the bottom of the chart.
2. Follow the vertical line up to the intersection with the selected fluid outlet pressure curve. Follow left to the scale to read the fluid out pressure.

Calculate Electrical Power

To calculate electrical power (W) at a specific fluid flow (gpm/lpm), use the following instructions and pump data chart.

1. Refer to the desired flow along the bottom of the chart.
2. Follow the vertical line up to the intersection with the selected electrical power curve. Follow right to the scale to read the fluid out pressure.

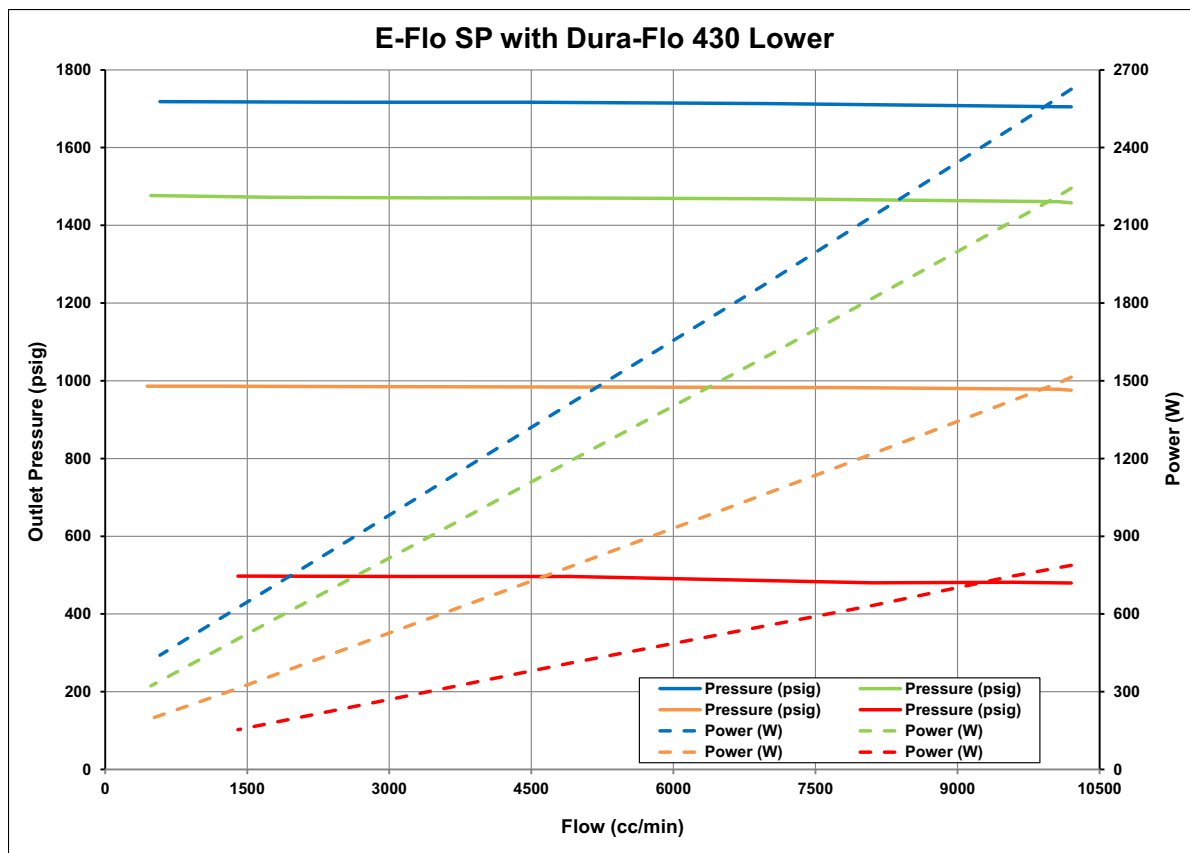

FIG. 34: E-Flow SP Performance Chart

NOTE: Performance is measured using 10 weight oil.

Technical Specifications

E-Flo SP Electric Pumps		
	US	Metric
Driver Thrust	4,840 lbs	21.5 kN, 2.2 kg
Stroke length	4.75 in.	120.7 mm
Maximum fluid operating temperature	180° F	82.3° C
Maximum driver cycle rate	25 cycles per minute	
Driver line voltage rating	200-240 VAC, single phase, 50/60 Hz	
Driver peak input amperage	20 A per phase @ full load*	
Input current	20 A maximum	
Fluid Outlet Size - all pump materials		
Check-Mate 100, 200, 250	1 in. NPT, female	
Check-Mate 500	1-1/2 in. NPT, female	
Dura-Flow 115, 145, 180, 220, 290	1 in. NPT, female	
Dura-Flow 430	1-1/2 in. NPT, female	
Maximum Fluid Working Pressure		
100cc Check-Mate - All	6000 psi	414 bar, 41.4 MPa
200cc Check-Mate - All	4200 psi	290 bar, 29.0 MPa
250cc Check-Mate - All	3400 psi	234 bar, 23.4 MPa
500cc Check-Mate - All	1600 psi	110 bar, 11.0 MPa
145cc Dura-Flo - SS	5600 psi	386 bar, 38.6 MPa
180cc Dura-Flo - SS	4500 psi	310 bar, 31.0 MPa
220cc Dura-Flo - SS	3700 psi	255 bar, 25.5 MPa
290cc Dura-Flo - SS	2800 psi	193 bar, 19.3 MPa
430cc Dura-Flo - SS	1900 psi	131 bar, 13.1 MPa
115cc Dura-Flo - CS	6000 psi	414 bar, 41.4 MPa
145cc Dura-Flo - CS	5600 psi	386 bar, 38.6 MPa
180cc Dura-Flo - CS	4500 psi	310 bar, 31.0 MPa
220cc Dura-Flo - CS	3700 psi	255 bar, 25.5 MPa
290cc Dura-Flo - CS	2800 psi	193 bar, 19.3 MPa
Motor Oil		
Specification	Graco part no. 16W645, ISO220 silicone-free synthetic EP gear oil**	
Capacity	1.5 quarts	1.4 liters
Notes		
* Full load amps with all devices operating at maximum capabilities.		
** The driver gearbox is shipped from the factory pre-filled with oil. Additional oil must be purchased separately.		

E-Flo SP Electric Pumps	
	US
	Metric
Wetted Materials	
Check-Mate - All	See separate pump manual in Related Manuals on page 2
Dura-Flo 115, 145, 180, 220, 290 CS	See separate pump manual in Related Manuals on page 2
Dura-Flo 145, 180, 220, 290 SS	See separate pump manual in Related Manuals on page 2
Dura-Flo 430 CS, SS, SM	See separate pump manual in Related Manuals on page 2
Sound Data (dBa)	
See APD20 Driver Instructions-Parts manual in Related Manuals on page 2 for sound data.	
Fluid Inlet Sizes	
Check-Mate	Not applicable
Dura-Flo	
145SS, 180SS	1 1/2 in. NPT, female
220SS, 290SS, 430SS, 430CS, 430SM	2 in. NPT, female
115CS, 145CS, 180CS, 220CS, 290CS	1 1/4 in. NPT, male

Weight								
Model	No ADM/240		No ADM/480		ADM/240		ADM/480	
	lbs	kg	lbs	kg	lbs	kg	lbs	kg
100cc Check-Mate - All	173	78.5	243	110.2	178	80.7	248	112.5
200cc Check-Mate - All	201.5	91.4	271.5	123.2	206.5	93.7	276.5	125.4
250cc Check-Mate - All	201.5	91.4	271.5	123.2	206.5	93.7	276.5	125.4
500cc Check-Mate - All	229	103.9	299	135.6	234	106.1	304	137.9
115cc Dura-Flo	165.5	75.1	235.5	106.8	170.5	77.3	240.5	109.1
145cc Dura-Flo - CS	175.5	79.6	245.5	111.4	180.5	81.9	250.5	113.6
145cc Dura-Flo - SS	166.75	75.6	236.5	107.3	171.5	77.78	241.5	109.5
180cc Dura-Flo - CS	175.5	79.6	245.5	111.4	180.5	81.9	250.5	113.6
180cc Dura-Flo - SS	167.5	76	237.5	107.7	172.5	78.2	242.5	110
220cc Dura-Flo - CS	179.5	81.4	249.5	113.2	184.5	83.7	254.5	115.4
220cc Dura-Flo - SS	200.5	90.9	270.5	122.7	205.5	93.2	275.5	125
290cc Dura-Flo - CS	180.5	81.9	250.5	113.6	185.5	84.1	255.5	115.9
290cc Dura-Flo - SS	200.5	90.9	270.5	122.7	205.5	93.2	275.5	125
430cc Dura-Flo - All	215	97.5	285	129.3	220	99.8	290	131.5

Graco Standard Warranty

Graco warrants all equipment referenced in this document which is manufactured by Graco and bearing its name to be free from defects in material and workmanship on the date of sale to the original purchaser for use. With the exception of any special, extended, or limited warranty published by Graco, Graco will, for a period of twelve months from the date of sale, repair or replace any part of the equipment determined by Graco to be defective. This warranty applies only when the equipment is installed, operated and maintained in accordance with Graco's written recommendations.

This warranty does not cover, and Graco shall not be liable for general wear and tear, or any malfunction, damage or wear caused by faulty installation, misapplication, abrasion, corrosion, inadequate or improper maintenance, negligence, accident, tampering, or substitution of non-Graco component parts. Nor shall Graco be liable for malfunction, damage or wear caused by the incompatibility of Graco equipment with structures, accessories, equipment or materials not supplied by Graco, or the improper design, manufacture, installation, operation or maintenance of structures, accessories, equipment or materials not supplied by Graco.

This warranty is conditioned upon the prepaid return of the equipment claimed to be defective to an authorized Graco distributor for verification of the claimed defect. If the claimed defect is verified, Graco will repair or replace free of charge any defective parts. The equipment will be returned to the original purchaser transportation prepaid. If inspection of the equipment does not disclose any defect in material or workmanship, repairs will be made at a reasonable charge, which charges may include the costs of parts, labor, and transportation.

THIS WARRANTY IS EXCLUSIVE, AND IS IN LIEU OF ANY OTHER WARRANTIES, EXPRESS OR IMPLIED, INCLUDING BUT NOT LIMITED TO WARRANTY OF MERCHANTABILITY OR WARRANTY OF FITNESS FOR A PARTICULAR PURPOSE.

Graco's sole obligation and buyer's sole remedy for any breach of warranty shall be as set forth above. The buyer agrees that no other remedy (including, but not limited to, incidental or consequential damages for lost profits, lost sales, injury to person or property, or any other incidental or consequential loss) shall be available. Any action for breach of warranty must be brought within two (2) years of the date of sale.

GRACO MAKES NO WARRANTY, AND DISCLAIMS ALL IMPLIED WARRANTIES OF MERCHANTABILITY AND FITNESS FOR A PARTICULAR PURPOSE, IN CONNECTION WITH ACCESSORIES, EQUIPMENT, MATERIALS OR COMPONENTS SOLD BUT NOT MANUFACTURED BY GRACO. These items sold, but not manufactured by Graco (such as electric motors, switches, hose, etc.), are subject to the warranty, if any, of their manufacturer. Graco will provide purchaser with reasonable assistance in making any claim for breach of these warranties.

In no event will Graco be liable for indirect, incidental, special or consequential damages resulting from Graco supplying equipment hereunder, or the furnishing, performance, or use of any products or other goods sold hereto, whether due to a breach of contract, breach of warranty, the negligence of Graco, or otherwise.

FOR GRACO CANADA CUSTOMERS

The Parties acknowledge that they have required that the present document, as well as all documents, notices and legal proceedings entered into, given or instituted pursuant hereto or relating directly or indirectly hereto, be drawn up in English. Les parties reconnaissent avoir convenu que la rédaction du présente document sera en Anglais, ainsi que tous documents, avis et procédures judiciaires exécutés, donnés ou intentés, à la suite de ou en rapport, directement ou indirectement, avec les procédures concernées.

Graco Information

Sealant and Adhesive Dispensing Equipment

For the latest information about Graco products, visit www.graco.com.

For patent information, see www.graco.com/patents.

TO PLACE AN ORDER, contact your Graco distributor, go to www.graco.com, or call to identify the nearest distributor.

If calling from the USA: 1-800-746-1334

If calling from outside the USA: 0-1-330-966-3000

All written and visual data contained in this document reflects the latest product information available at the time of publication. Graco reserves the right to make changes at any time without notice.

Original instructions. This manual contains English. MM 3A6586

Graco Headquarters: Minneapolis

International Offices: Belgium, China, Japan, Korea

GRACO INC. AND SUBSIDIARIES • P.O. BOX 1441 • MINNEAPOLIS MN 55440-1441 • USA
Copyright 2016, Graco Inc. All Graco manufacturing locations are registered to ISO 9001.

www.graco.com
Revision A, January 2019