

# HV-2000C Jet Controller

3A5856C

Diaphragm-Jet™ Technology

EN

HV-2000 Jet Controller, P/N HV-2000C-AD

For non-contact dispensing of viscous material in industrial environments.

For professional use only.

Not approved for use in explosive atmospheres or hazardous locations.



### Important Safety Instructions

Read all warnings and instructions in this manual and all related manuals before using this equipment. Save these instructions.



# Table of Contents

<b>RELATED MANUALS</b> .....	<b>4</b>
<b>WARNINGS</b> .....	<b>5</b>
<b>1. INTRODUCTION AND SPECIFICATIONS</b> .....	<b>6</b>
1.1 Advanjet HV-2000/2000C Overview .....	6
1.2 HV-2000C Controller Specifications .....	7
1.3 Technical Assistance .....	7
1.4 HV-2000C Controller Dimensions .....	8
1.5 HV-2000C Front Panel Features .....	9
1.6 HV-2000C Rear Panel Features .....	9
<b>2. INSTALLATION AND SETUP</b> .....	<b>10</b>
2.1 Physical Placement .....	10
2.2 Pneumatic Connections .....	10
2.3 Cable Connections .....	11
2.4 Input / Output Connections .....	12
<b>3. USING THE HV-2000C CONTROLLER FRONT PANEL</b> .....	<b>13</b>
3.1 Jet and Fluid Pressure Regulators .....	13
3.2 Temperature Controller .....	14
3.3 Trigger Button and LED .....	15
3.4 LCD Display and Selection Keys .....	16
3.5 Jet Setting from the Front Panel .....	16
3.6 Special Front Panel Key Sequences .....	18
<b>4. RS-232 COMMUNICATION</b> .....	<b>19</b>
4.1 RS-232 Connector Pins .....	19
4.2 Changing the Default RS-232 Settings .....	20
<b>5. ADVANJET SOFTWARE</b> .....	<b>21</b>
5.1 Installing and Starting Up the Software .....	21
5.2 Settings Menu .....	22
5.3 Running a Program from Software .....	25
<b>6. TIMING RECIPES</b> .....	<b>26</b>
6.1 Timing Recipe Parameters .....	26
6.2 Programming Timing Recipes .....	27
6.3 DROP Mode Programming .....	29
Dispensing one drop at a time .....	29
Dispensing multiple drop sizes .....	29
6.4 LINE Mode Programming .....	30
Method 1: Jetting a line in PULSE mode .....	30
Method 2: Jetting a line in LEVEL Mode .....	30
Method 3: Jetting a line during an X-Y move .....	31

## Table of Contents

<b>7.</b>	<b>ADVANJET CONTROLLER COMMANDS (ACC)</b> .....	<b>32</b>
7.1	The RS-232 Interface .....	32
7.2	Command Format.....	32
7.3	Recipe Timing Commands .....	33
7.4	Jetting Commands.....	34
7.5	Heater Commands .....	37
7.6	Output Commands .....	38
	<b>APPENDIX 1: FIRST DROP COMPENSATION</b> .....	<b>39</b>
	Appendix 1-1: Background .....	39
	Appendix 1-2: Calculating First Drop Compensation.....	39
	Appendix 1-3: First Drop Compensation in PULSE Mode .....	40
	Appendix 1-4: First Drop Compensation in LEVEL Mode.....	42
	<b>APPENDIX 2: TEMPERATURE CONTROLLER FACTORY SETTINGS</b> .....	<b>43</b>
	<b>APPENDIX 3: DIGITAL PRESSURE GAUGE</b> .....	<b>44</b>
	Appendix 3-1: Specifications .....	44
	Appendix 3-2: Part Names and Functions .....	45
	Appendix 3-3: Connections and Input/Output Circuit.....	46
	Appendix 3-4: Operation Mode Selection .....	47
	Appendix 3-5: Operation Mode Selection .....	48
	Appendix 3-6: Adjustment .....	49
	Appendix 3-7: Other Functions and Error Indications.....	50
	<b>APPENDIX 4: INPUT/OUTPUT CONNECTOR</b> .....	<b>51</b>
	Appendix 4-1: HD26 Pin Assignments .....	51
	Appendix 4-2: Schematic for Configurable I/O DIO0-DIO31 .....	54
	Appendix 4-3: Schematic for Buffered A/D Converter Inputs .....	55
	Appendix 4-4: Schematic for D/A Converter Outputs .....	56
	Appendix 4-5: Schematic for Pressure Alarm Input/Output Circuit.....	57
	<b>GRACO STANDARD WARRANTY</b> .....	<b>58</b>







## Related Manuals

Manuals are available at [www.graco.com](http://www.graco.com). Component manuals below are in English:

3A5855	HV-2000 Jet Setup and Operation
3A5908	Advanjet Jet Maintenance Tool Kit (JKT-2000)
3A5909	HV-2000 Maintenance and Repair

# Warnings

The following warnings are for the setup, use, grounding, maintenance, and repair of this equipment. The exclamation point symbol alerts you to a general warning and the hazard symbols refer to procedure-specific risks. When these symbols appear in the body of this manual or on warning labels, refer back to these Warnings. Product-specific hazard symbols and warnings not covered in this section may appear throughout the body of this manual where applicable.

 <b>WARNING</b>	
	<p><b>ELECTRIC SHOCK HAZARD</b> This equipment must be grounded. Improper grounding, setup, or usage of the system can cause electric shock.</p> <ul style="list-style-type: none"> <li>▪ Turn off and disconnect power cord before servicing equipment.</li> <li>▪ Connect only to grounded electrical outlets.</li> <li>▪ Use only 3-wire extension cords.</li> <li>▪ Ensure ground prongs are intact on power and extension cords.</li> </ul>
	<p><b>TOXIC FLUID OR FUMES HAZARD</b> Toxic fluids or fumes can cause serious injury or death if splashed in the eyes or on skin, inhaled, or swallowed.</p> <ul style="list-style-type: none"> <li>▪ Read Safety Data Sheets (SDSs) to know the specific hazards of the fluids you are using.</li> <li>▪ Store hazardous fluid in approved containers and dispose of it according to applicable guidelines.</li> </ul>
	<p><b>BURN HAZARD</b> Equipment surfaces and fluid that is heated can become very hot during operation. To avoid severe burns: Do not touch hot fluid or equipment.</p>
	<p><b>PERSONAL PROTECTIVE EQUIPMENT</b> Wear appropriate protective equipment when in the work area to help prevent serious injury, including eye injury, hearing loss, inhalation of toxic fumes, and burns. Protective equipment includes but is not limited to:</p> <ul style="list-style-type: none"> <li>▪ Protective eyewear, and hearing protection.</li> <li>▪ Respirators, protective clothing, and gloves as recommended by the fluid and solvent manufacturer.</li> </ul>
	<p><b>EQUIPMENT MISUSE HAZARD</b> Misuse can cause death or serious injury.</p> <ul style="list-style-type: none"> <li>▪ Do not operate the unit when fatigued or under the influence of drugs or alcohol.</li> <li>▪ Do not exceed the maximum working pressure or temperature rating of the lowest rated system component. See Technical Specifications in all equipment manuals.</li> <li>▪ Use fluids and solvents that are compatible with equipment wetted parts. See Technical Specifications in all equipment manuals. Read fluid and solvent manufacturer's warnings. For complete information about your material, request SDSs from distributor or retailer.</li> <li>▪ Turn off all equipment and relieve air pressure when equipment is not in use.</li> <li>▪ Check equipment daily. Repair or replace worn or damaged parts immediately with genuine manufacturer's replacement parts only.</li> <li>▪ Do not alter or modify equipment. Alterations or modifications may void agency approvals and create safety hazards.</li> <li>▪ Make sure all equipment is rated and approved for the environment in which it is used.</li> <li>▪ Use equipment only for its intended purpose. Contact your distributor for information.</li> <li>▪ Route hoses and cables away from traffic areas, sharp edges, moving parts, and hot surfaces.</li> <li>▪ Do not kink or over bend hoses or use hoses to pull equipment.</li> <li>▪ Keep children and animals away from work area.</li> <li>▪ Comply with all applicable safety regulations.</li> </ul>

# 1. Introduction and Specifications

---

## 1.1 Advanjet HV-2000/2000C Overview

---

The Advanjet HV-2000C controller provides timing signals as well as pneumatic and electrical resources for the Advanjet HV-2000 Jet Valve.

- The HV-2000C provides timing signals to drive a rapid-response solenoid valve in the HV-2000 Jet Valve. Its internal computer remembers and executes a variety of operational sequences. The controller can respond to actuation signals from either a front panel switch or from an external switch.
- The HV-2000C provides regulated, pressurized air for the fluid pressure and jet pressure of the HV-2000 Jet Valve.
- The HV-2000C provides electrical power to a heater element in the HV-2000 Jet Valve and controls the temperature of the valve's heater by monitoring a resistance temperature detector (RTD) sensor in the HV-2000 Jet Valve.

---

## 1.2 HV-2000C Controller Specifications

---

PARAMETER	SPECIFICATION
Size	Width: 254.0 mm (10.00 in) Height: 152.5 mm (6.00 in) Depth: 341.4 mm (13.44 in) Weight: 3200 g (7.05 lbs)
Drop Parameters	Refill time and Dwell (0.1 msec resolution) Number of drops (programmable from 1 to 1M)
Recipes	6 independent recipes, manual or remote triggers
Nozzle Heater	Heating to 70 °C Max ± 1.0 °C @ 50 °C PID control using platinum RTD, Auto tuning 24 VDC, 5.7 W, 100 Ω Programmable shutoff timer 2 alarms for process control
First Drop Compensation	2 levels with programmable time interval
Interface	RS-232 Serial Port LCD Display with Keypad
Input/Output	TTL level triggers
Operating Temperature	15 °C to 50 °C (59 °F to 122 °F)
Input Pressure	0.6 MPa (90 psi) - maximum
Input Power	100 – 240 VAC, 50/60 Hz, 115 W Fuse: 5x20 mm, Fast-acting, 1.6 amp, 250 VAC
Advanjet Software	Windows XP, Vista, Windows 7 and Windows 8
Approvals	

---

## 1.3 Technical Assistance

---

Advanjet  
926 Andreasen Dr. # 108  
Escondido, CA 92029  
USA

Phone: +1 800 333 4877  
Web: [www.advanjet.com](http://www.advanjet.com)  
E-mail: [info@advanjet.com](mailto:info@advanjet.com)

### 1.4 HV-2000C Controller Dimensions

Shown below are the mechanical dimensions of the HV-2000C. Units are in millimeters [inches].

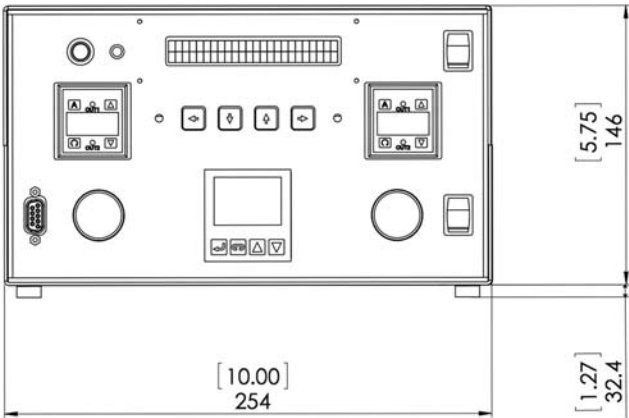
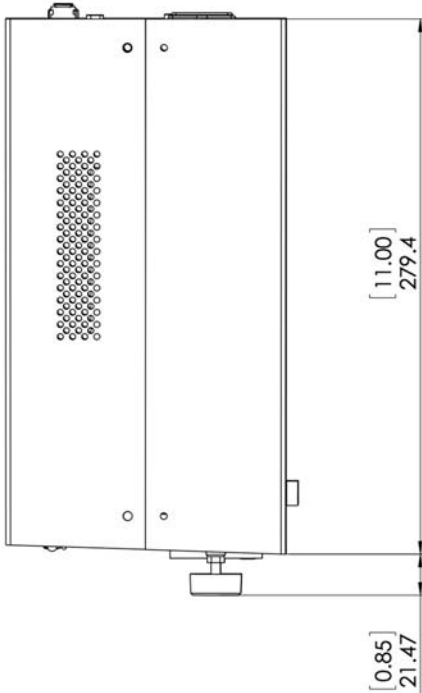
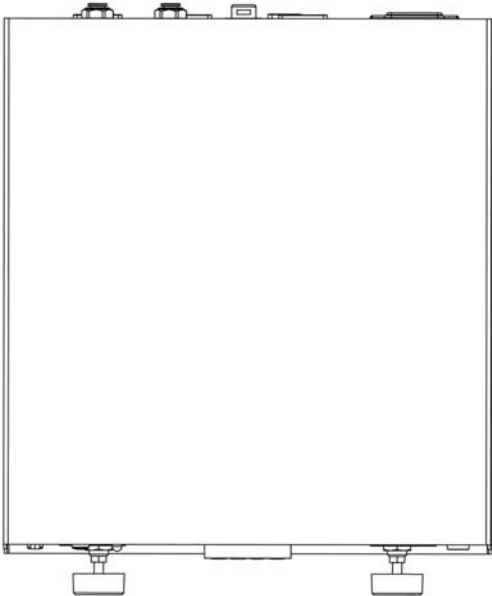



## 1.5 HV-2000C Front Panel Features

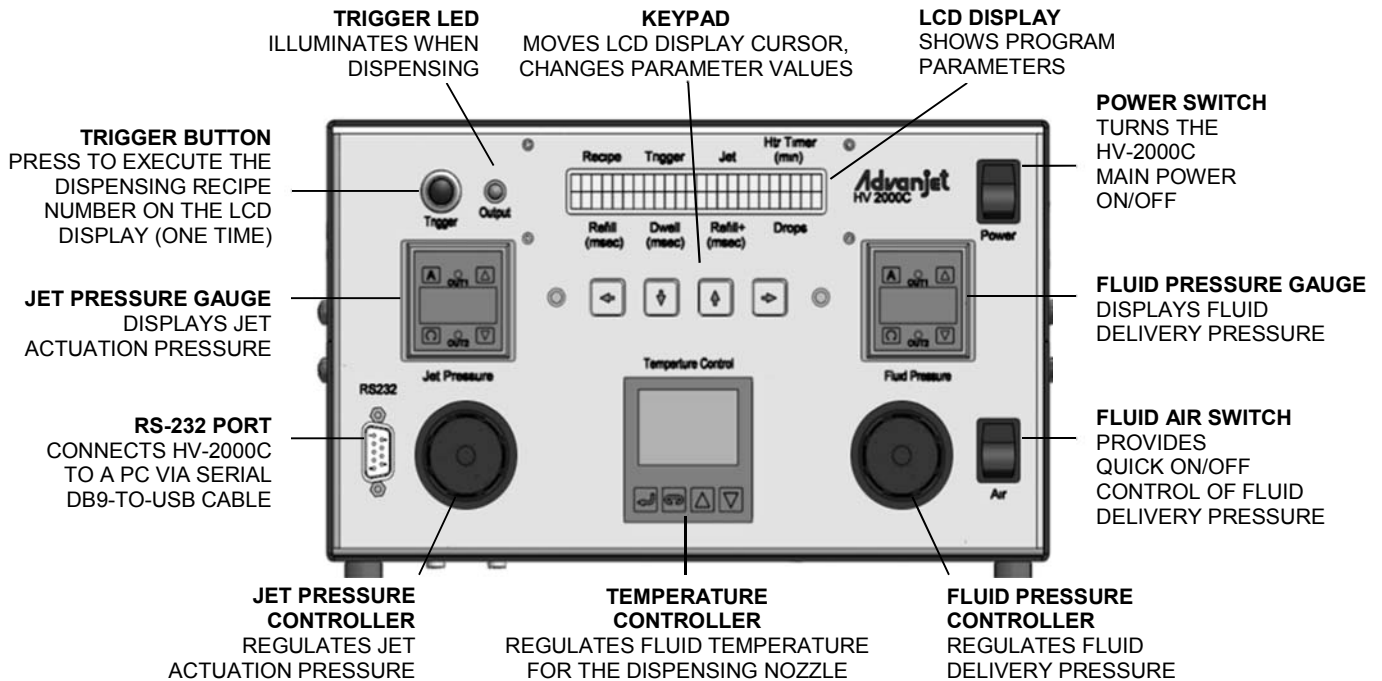

## 1.6 HV-2000C Rear Panel Features

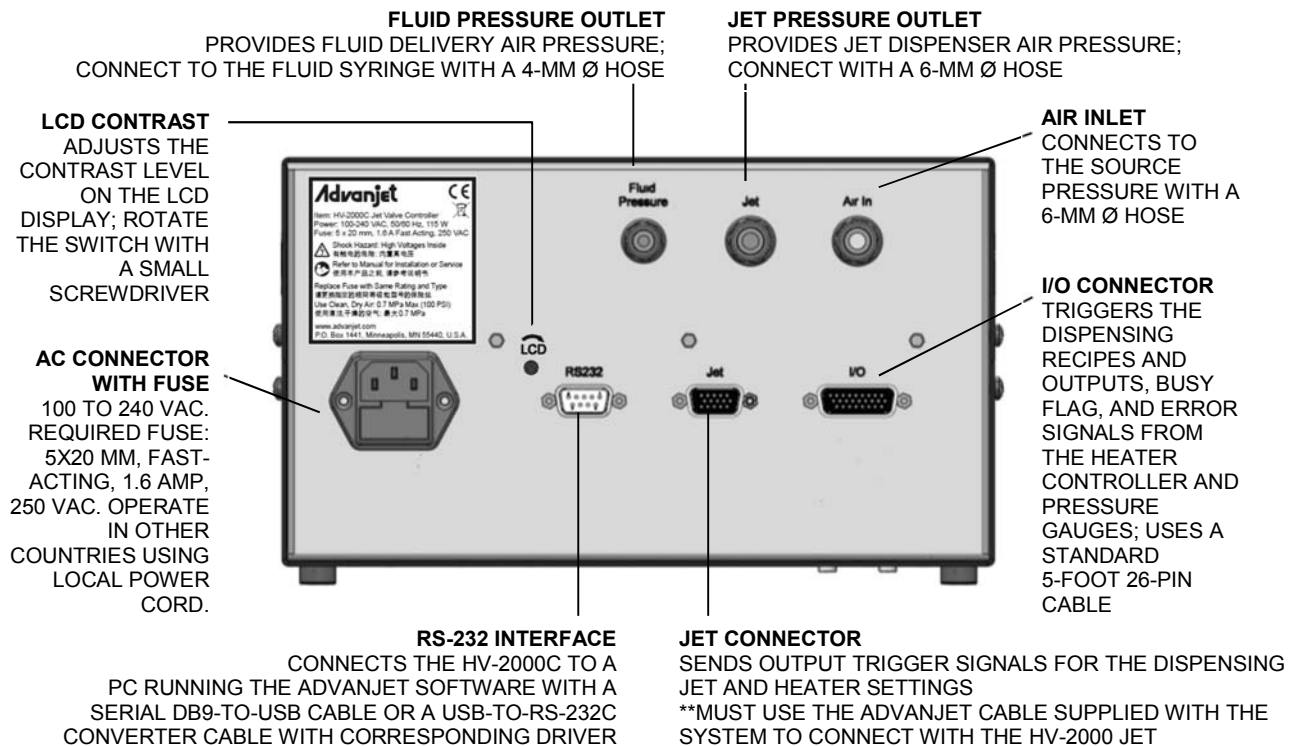

## 2. Installation and Setup

### 2.1 Physical Placement

The HV-2000C controller should be placed in a location where the front panel controls can be viewed and accessed. The ventilation holes on the sides should not be blocked.

### 2.2 Pneumatic Connections

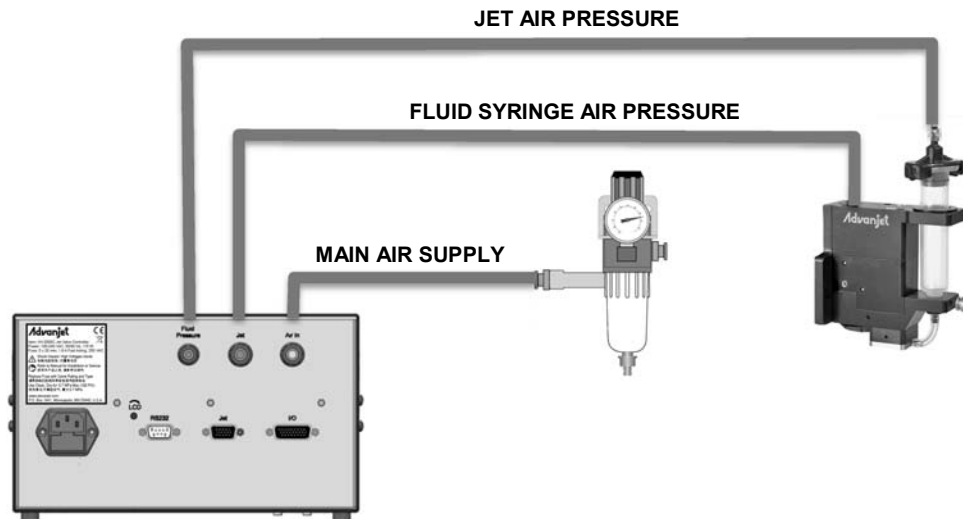

Figure 2-1: HV-2000C Pneumatic Connections

**Main Air Supply:** Connect a filtered (40-micron filter or better) and independently regulated main air source. It is highly recommended to place a drying system or desiccant dryer in line with the main air line. A 6mm OD air tube with a slip connect coupler is supplied to connect the HV-2000C to the main air supply. The main air supply pressure should be between 70 to 100 psi (0.48 and 0.70 MPa).

**Jet Air Pressure:** The HV-2000C delivers jet air pressure through black 6 mm OD tubing with a quick-connect coupler to the controller and an air fitting for the jet. The jet air supply must be clean and dry and at a maximum pressure of 75 psi (0.51 MPa); normal jet air operation is usually between 35 and 75 psi (0.24 and 0.51 MPa).

**Fluid Syringe Air Pressure:** The HV-2000C delivers fluid syringe air pressure through clear 4 mm OD tubing that is attached to the receiver head and has a twist-lock connector to the controller. The fluid syringe air supply should be at maximum 60 psi (0.41 MPa); normal fluid pressure is usually between 10 and 50 psi (0.06 and 0.34 MPa). Variations in the air pressure source can adversely affect the consistency of the drop size.

#### NOTICE

It is imperative that the air supplied to the HV-2000 is clean and dry and free from debris and water. A 40-micron filter, a water separator, and an overpressure relief valve set at around 120 psi (0.83 MPa) are highly recommended. If the air is not clean and dry, serious damage can occur to the solenoid valves.

## 2.3 Cable Connections

Four cable connections are on the rear of the Advanjet controller: Power cord, RS-232, Jet, and Digital I/O, as shown in Figure 2-2. To assure proper connections to the Advanjet controller, each of the standard cables supplied by Advanjet has a distinct

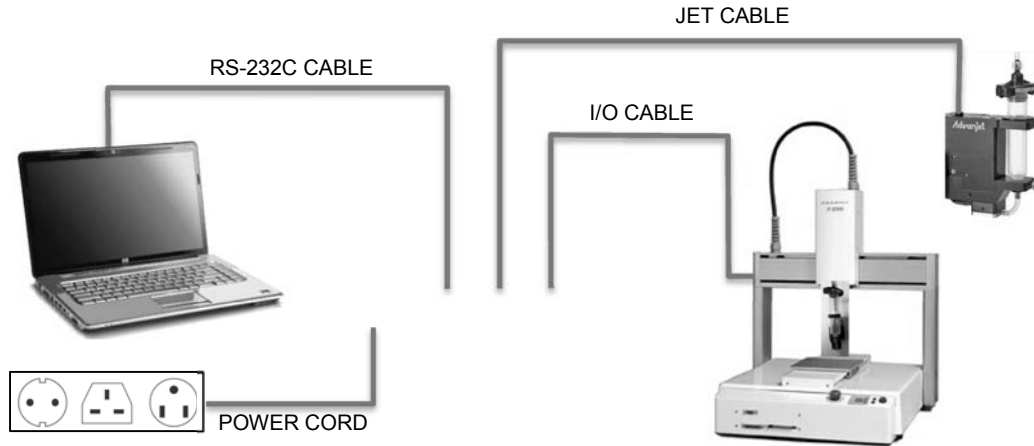

Figure 2-2: HV-2000C Cable Connections

connector.

**Jet:** The Jet cable is a high-density HD-15 cable and should be attached directly to the HV-2000 Jet and the controller.

**I/O:** The HV-2000C provides six TTL trigger lines to control jet operations through a 26-pin cable that connects the jet to a robot. See Section 2.4 for more details.

**RS-232:** The Advanjet software requires an RS-232C communication interface with the Advanjet controller. For computers without an RS-232C port, use a USB to RS-232C



converter cable with the drivers that come with the cable. Advanjet can supply an RS-232C-to-USB cable and corresponding driver.

**Power:** The power cord kit included with the controller (P/N 26A545) has a cord for each region as follows:

- Standard 115V, 10A, for USA, Mexico, Canada, Taiwan, and similar
- 250V cord for continental Europe
- Adapter for UK, Australia and similar

The Advanjet grounded power cord. power cord to a grounded before



The equipment must be grounded to reduce the risk of static sparking and electric shock. Electric or static sparking can cause fumes to ignite or explode. Improper grounding can cause electric shock. Grounding provides an escape wire for the electric current.

controller is through the Connect the properly power source operating.

---

## 2.4 Input / Output Connections

---

A standard, 5-foot 26-pin Input/Output cable is supplied with the HV-2000C. The table below describes the I/O connector pin assignments. The I/O is configured for the inputs to be pulled down to GND. When the specific input is triggered, the Advanjet controller will activate the corresponding preprogrammed Recipe # shown.

- Pins 1 through 6 are outputs from the robot to the Advanjet controller. They can be TTL outputs capable of sinking 2 mA of current, or they can also be relay contacts.
- Pin 7 outputs a busy status flag from the Advanjet controller to the robot.
- Pin 8 is an external interrupt used to remotely stop a dispensing program.
- Pins 9 and 14 are Isolated Ground.
- Pins 18-26 are alarms from the heater and pressure sensors.

I/O PIN ASSIGNMENTS	
HD26	HV-2000C
1	Recipe 1 (Input)
2	Recipe 2 (Input)
3	Recipe 3 (Input)
4	Recipe 4 (Input)
5	Recipe 5 (Input)
6	Recipe 6 (Input)
7	Busy Flag (Output)
8	External Interrupt (Input)
9	GND
10	D/A Converter Output
11	Buffered A/D Converter Inputs
12	Buffered A/D Converter Inputs
13	D/A Converter Output
14	GND
15	No connection
16	No connection
17	No connection
18	Heater Alarm Common (Output)
19	Fluid Pressure Alarm Common 2
20	Fluid Pressure Alarm 2 (Output)
21	Fluid Pressure Alarm 1 (Output)
22	Jet Pressure Alarm Common 1
23	Jet Pressure Alarm 2 (Output)
24	Jet Pressure Alarm 1 (Output)
25	Heater Alarm 1 (Output)
26	Heater Alarm 2 (Output)

**Note:** Refer to Appendix 4 for I/O connection details.

### 3. Using the HV-2000C Controller Front Panel

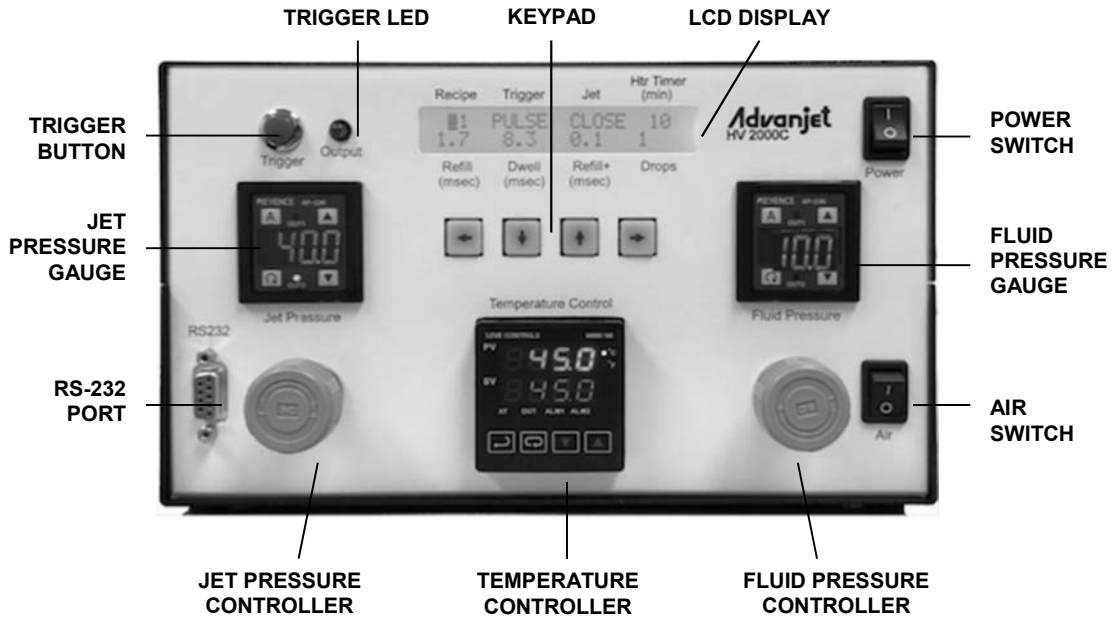

Figure 3-1: HV-2000C Front Panel

#### 3.1 Jet and Fluid Pressure Regulators

The HV-2000C controller has two integrated air regulators (see Figure 3-2) that control the pressure to the Jet and the Fluid supply. Turn the knob clockwise to increase and counterclockwise to decrease. Digital gauges indicate the pressure levels; the Jet Pressure gauge is pictured below. The default pressure unit on the HV-2000C is psi (1 psi = 0.00689 MPa). Details from the pressure regulator manufacturer are in Appendix 3: Digital Pressure Gauge.

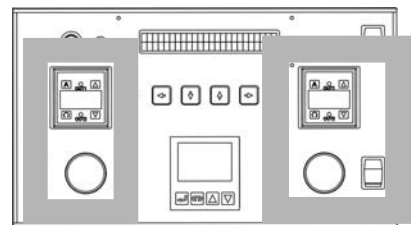

Figure 3-2: Pressure Regulators and Air Switch



Figure 3-3: Jet Pressure Gauge

The Air Switch allows the operator to instantly turn the Fluid Pressure ON or OFF. This is very convenient when changing fluid or cleaning the jet.





Figure 3-4: Air Switch

## 3.2 Temperature Controller

The HV-2000C Temperature Controller regulates the temperature of the dispensing fluid and displays the present and set point temperatures.

The main menu displays the present temperature value (PV) in red on the top line of the display and the set point temperature value (SV) in green on the bottom line of the display.

Use the  (INDEX) key to cycle through the menu options on the PV line, the  keys to scroll through settings or increase or decrease temperature values, and the  (ENTER) key to save an input and exit the menu.

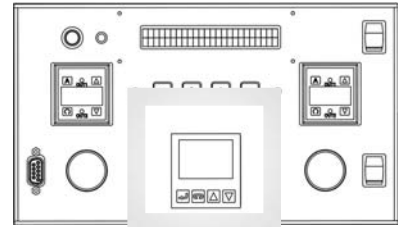

Figure 3-5:  
Temperature Controller

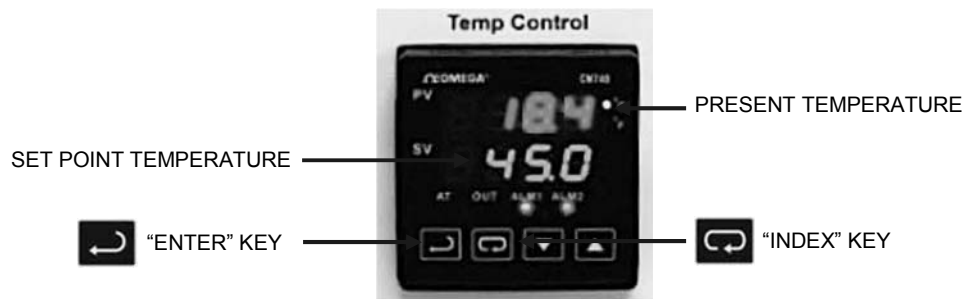

Figure 3-6: Present Value (PV) , Set Value (SV),  
ENTER Key and INDEX Key

To turn ON the heater:





- Press  until the Run-Stop Output Control screen (**r-S**) is on the PV line.
- Use the  keys to select the **rUn** setting to turn ON the heater.
- Press the  key to save the change. Now the heater is turned ON.
- Press the  key again to return to the main screen display.



Figure 3-7: Turn ON the Heater

---

## 3.2 Temperature Controller (Continued)

---

To turn OFF the heater:





- Press  until the Run-Stop screen is displayed (r-S).
- Use the  keys to select the **Stop** setting.
- Press the  key to save the change. Now the heater is turned OFF.
- Press the  key again to return to the main screen display.



Figure 3-8: Turn OFF the Heater

To change the Set Value (SV) temperature:







- Use the  keys to increase or decrease the value. For example, to change SV from 20 to 45 degrees, use the  key to increase the SV value to 45.
- Press  to save the change.



Figure 3-9: Press  to increase the SV value to 45, then press  to save the change

Technical specifications of the heater can be found in Appendix 2: Temperature Controller Factory Settings.

---

## 3.3 Trigger Button and LED

---

Pressing the **Trigger Button** immediately executes the current recipe (recipe # and parameters) displayed on the LCD screen one time. If multiple drops were specified in the recipe, multiple drops will be dispensed.

The **Trigger Output LED** is on when the Jet is firing to verify a signal was sent to the Jet. The light is off when the Jet is in idle state.

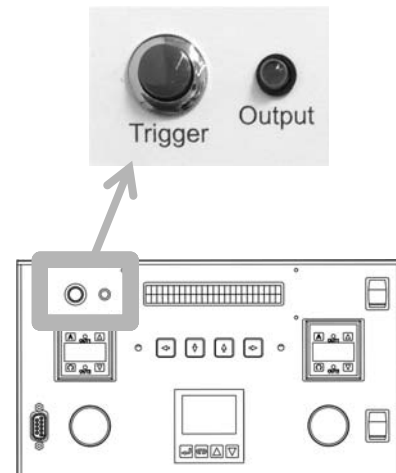

Figure 3-10:  
Trigger Button and Output LED

### 3.4 LCD Display and Selection Keys

HV-2000C front panel programming and operation uses the LCD display and input keypad, highlighted in Figure 3-11 at right. Eight basic settings can be input from the main LCD menu. The selected setting is indicated by a blinking cursor.

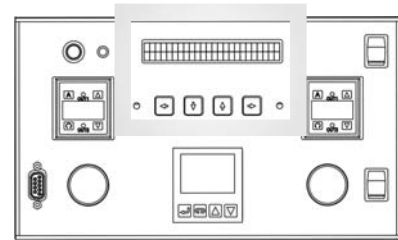

Figure 3-11:  
LCD Display and Selection Keys

Recipe	Trigger	Jet	Htr Timer (min)
#1	PULSE	CLOSE	0
2.5	17.5	0.3	1
Refill (msec)	Dwell (msec)	Refill+ (msec)	Drops

Figure 3-12: LCD Display with Cursor at Recipe #

Figure 3-12 shows the cursor selecting the Recipe #. Use the LEFT/RIGHT keys to move the cursor and the UP/DOWN keys to increment the values.

### 3.5 Jet Setting from the Front Panel

The eight jetting parameters on the LCD display can be programmed from the input keypad.

**Recipe:** Select the recipe number from 1 to 6. Each recipe consists of the Trigger mode, Refill time, Dwell time, Refill+ time (“first drop” adjustment), and the number of drops to dispense. Up to 6 dispensing recipes can be programmed and saved in the controller.

**Trigger:** There are two Trigger modes—PULSE or LEVEL.

In the PULSE mode, the number of drops dispensed per trigger signal is specified in the **Drops** setting. For example, if a recipe has set **Trigger** to PULSE and **Drops** to 5, the jet will dispense 5 drops per Trigger signal. Pressing the Trigger button in PULSE mode sends a Trigger signal and the jet will dispense 5 drops.

In the LEVEL mode, the jet will dispense drops nonstop until the **Trigger** signal retreats—the **Drops** count is ignored. Pressing the Trigger button in LEVEL mode causes LEVEL mode to be ignored, and the jet will dispense the number of drops specified in the **Drops**.

**Jet:** Use this to CLOSE or OPEN the Jet valve.

**Htr Timer (min):** The Heater Off timer automatically turns off the heater after the Jet has been idle for the specified number of minutes. This feature is useful if materials will be adversely affected by long periods of heating. For example, some materials can be “cured” by high temperature while sitting in the nozzle chamber for a long period of idle time. If **Htr Timer** is set to zero, the Heater Off timer is not activated.



---

### 3.5 Jet Setting from the Front Panel (Continued)

---

**Refill (msec):** Refill time is the time required for the material to flow into the nozzle after each drop is ejected. **Refill** is set in msec with 0.1 msec resolution. Section 6.1 - Timing Recipe Parameters provides a detailed explanation of Refill Time.

**Dwell (msec):** Dwell time is the time required for the material to flow out of the nozzle and form a drop. **Dwell** is set in msec with 0.1 msec resolution. Section 6.1 - Timing Recipe Parameters provides a detailed explanation of Dwell Time.

**Refill+ (msec):** Sometimes the jet requires a little extra time for the first drop to be ejected, depending on the material or if the jet is idle for a period of time. **Refill+** time is added to **Refill** time to adjust the size and quality of the first drop. In PULSE mode, Refill+ time applies to each drop; in LEVEL mode, Refill+ time applies to just the first drop. Detailed explanations can be found in Section 6.2 – Programming Timing Recipes (Adjust Refill Time for First Drop), and also Appendix 1: First Drop Compensation.

**Drops:** Specify the number of drops to be dispensed. To dispense a single drop per trigger signal, enter 1. To dispense 10 drops per trigger signal, enter 10.

**Note:** *If the Advanjet controller software is being used and values are changed using the front panel display, the changes will not be transferred to the Advanjet controller software. Also, the front panel values can be overwritten each time you start the Advanjet software program. The warning below will be displayed. It is recommended to write down any recipe changes made from the front panel and then enter them into the software to synchronize.*



**Figure 3-13: Advanjet Controller Overwrite Warning**

---

### 3.6 Special Front Panel Key Sequences

---

Pressing a combination of front panel keys accesses additional settings.

**Refill++ time:** Simultaneously pressing the LEFT and RIGHT keys once brings up the **Refill++** time menu. As another method of first drop compensation, **Refill++** time is added to **Refill** time after the jet is idled for a defined number of seconds. **Refill++** time applies to just the first drop in both PULSE and LEVEL modes. To access **Refill++**, press LEFT + RIGHT once. The screen on the right appears:

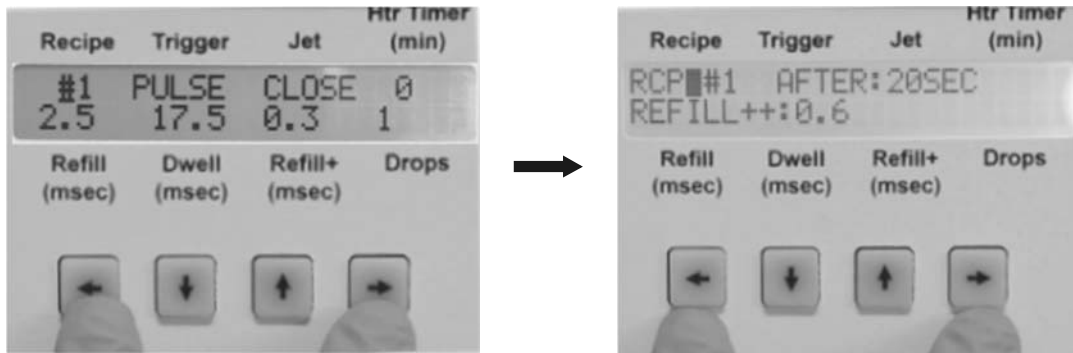

Figure 3-14: Press LEFT + RIGHT to Set the Refill++ Parameter

For **RCP**, enter the recipe number. **AFTER** is the jet idle time in seconds, and **REFILL++** is the extra refill time. For a detailed explanation, see Section 6.2 - Programming Timing Recipes (Adjust Refill Time for First Drop), and also Appendix 1: First Drop Compensation. After entering the **REFILL++** settings, simultaneously press the LEFT and RIGHT keys twice to accept the new settings and return to the main menu.

**RS-232 Settings:** Simultaneously pressing LEFT+RIGHT twice brings up the **RS-232 Settings** menu. This setting is explained in detail in Section 4.2 - Changing the Default RS-232 Settings. Press LEFT+RIGHT again to return to the main menu.

## 4. RS-232 Communication

### 4.1 RS-232 Connector Pins

On some HV-2000C models there is a serial port DB9P female connector located on the front panel. This RS-232 port is used to connect the controller to a PC using a USB-to-Serial Adapter cable. Connect the USB Plug end to the PC's USB port, and connect the Serial DB9 plug to the RS-232 port.

For system configurations that are not using a USB Serial RS-232 cable, the following table shows the correct RS-232 cable pin-outs when connecting directly from a PC serial port:

RS-232 Connector Pins		
Computer	Advanjet	Function
2	3	Rx ← Tx
3	2	Tx → Rx
4	6	DTR → DSR
5	5	GND
6	4	DSR ← DTR
7	8	RTS → CTS
8	7	CTS ← RTS

Figure 4-1: RS-232 Cable Pin-Outs

## 4.2 Changing the Default RS-232 Settings

The default settings for the RS-232 data interface are CTS ON, Baud Rate 57600, Parity NONE, and Data Length 8BIT. To change the default RS-232 settings, simultaneously press the LEFT and RIGHT keys twice. (Pressing L+R one time displays the Refill++ settings; pressing L+R a second time displays the RS-232 default settings.)



Figure 4-2: Press LEFT+RIGHT Keys Twice for the Default RS-232 Settings

Use the LEFT/RIGHT keys to cycle through the settings. The selected setting will have a blinking cursor. Use the UP/DOWN keys to cycle through the setting options:

SETTING	DEFAULT	OPTIONS
CTS (hardware handshake)	ON	ON or OFF
Baud Rate	57600	57600, 19200, 9600 or 4800
Parity	NONE	NONE, EVEN or ODD
Data Length	8BIT	8BIT or 7BIT

To accept the new RS-232 interface settings, simultaneously press and hold the LEFT and RIGHT keys. The LCD display will return to the main menu.

**Note:** Remember to check the RS-232 settings in the Advanjet Controller program. The settings in the HV-2000C controller should be the same as the settings in the program. The Advanjet Controller program and the HV-2000C controller will not be able to communicate with each other when they have different RS-232 settings.

## 5. Advanjet Software

The Advanjet software is not required if the controller will always be operated from the front panel keys. However, if a PC user interface is preferred, or if access to the controller front panel keys is limited, the Advanjet Software provides the option of programming the jetting parameters from a PC using Windows XP, Vista, Windows 7, and Windows 8.

### 5.1 Installing and Starting Up the Software

1. Insert the installation CD or obtain a link to download the Advanjet controller program from [www.Advanjet.com](http://www.Advanjet.com). Run Advanjet2000\_Installer.exe and follow the installation instructions.
2. Once the software is installed, connect the RS-232 cable from the PC to the HV-2000C controller, connect the pneumatics as shown in Figure 2-1, and connect jet cable to the controller. Turn on the controller and set the Jet Pressure to 40 psi (0.28 MPa).
3. Start the Advanjet software by clicking on the Advanjet2000 entry in the Start Programs menu. (A shortcut for this program can be created.)
4. On startup, the Advanjet Software program will poll the HV-2000C controller and automatically establish the RS-232C port and connection. A “Failed to find COM port for Advanjet Controller” message will appear if the program cannot establish communication with the controller. If this message appears, check the RS-232 cable for proper connection between the PC (see Section 4).

The Settings menu appears as shown below. Check that the Jet button [1] is Red and that the Controller Status [11] indicates “Ready.” The Advanjet program is ready.

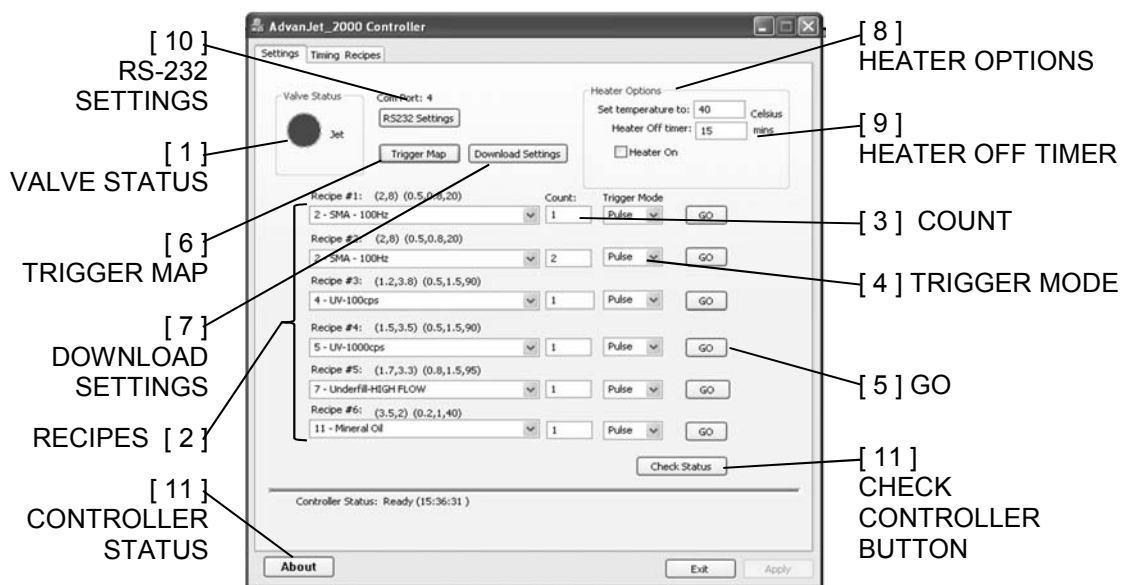

Figure 5-1: Advanjet Software Settings Menu

---

## 5.2 Settings Menu

---

This section describes features 1 – 11 of the Advanjet Software Settings Menu as shown in Figure 5-1 on the previous page.

1. **Valve Status:** Turn the Jet valve ON or OFF by clicking on the large indicator button (RED = ON, BLUE = OFF). The Jet valve is ON by default at startup. When the button is RED, the Jet valve is activated and it will block the fluid flow. If the button is BLUE, the Jet valve is OFF and fluid will flow freely. Generally, the user should rarely have to activate the valve manually.
2. **Recipe #1 to Recipe #6:** Up to six recipes can be programmed for the controller. Each recipe consists of Refill Time, Dwell Time, and “first drop” adjustment times for Refill, number of drops to dispense, and the Trigger mode.  
A pull-down menu is located below each Recipe #. When the pull-down menu is clicked, the Recipe List configured in the Timing Recipes menu is displayed (See Section 6). In the recipe list (2, 8) (0.5, 0.8, 20), the first bracket shows a Refill time of 2 msec and Dwell time of 8 msec. The second bracket shows that 0.5 msec will be added to the Refill time for the first drop (Refill+), and 0.8 msec will be added to the first drop if the idle time is greater than 20 seconds (Refill++). Click on the arrow to choose a recipe entry.
3. **Count:** The Count is the number of drops for the corresponding recipe. For example, to dispense a single drop of Recipe #1 SMA 100Hz (as shown in Figure 5-1), specify 1 in the Count. To dispense multiple drops, choose a number greater than one, as shown in Recipe #2.  
**Note:** refer to DROP mode programming (see Section 6.3) and LINE mode programming (see Section 6.4) for using the **Count** value to set the dispensing mode.
4. **Trigger Mode:** The Trigger Mode is either PULSE or LEVEL. In PULSE mode, the number of drops to dispense is specified in the **Count** entry. Referring again to Recipe #1, setting count to 5 and Trigger Mode to PULSE will cause the Jet to dispense 5 drops when the controller receives a falling edge signal (high to low) from the Recipe #1 Trigger.  
In LEVEL mode, the drops will be dispensed nonstop as long as the trigger signal remains low. Once the signal returns to high, the Jet will stop dispensing. In LEVEL mode, the **Count** value is ignored; number of drops is calculated by dividing the trigger signal time by the “jet busy” time. For example, if Recipe #1 has a Refill Time of 2 msec, a Dwell Time of 3 msec, and the falling edge signal has remained low for 100 msec, then the Jet will dispense 20 drops  $[100 \div (2+3)]$ .
5. **Go:** Click on **Go** to activate a recipe manually. Remember, as soon as a PULSE mode trigger has initiated the recipe (manually or remotely), the recipe activates for the number of times specified by the **Count** number, without stopping.

---

## 5.2 Settings Menu (Continued)

---

6. **Trigger Map:** Displays the assignment of the trigger input to the dispensing recipes. For example, in Figure 5-2 below, input trigger signal from I/O Pin 1 is used to activate Recipe #1. The BusyFlag (I/O Pin 7) is an output signal that the external controller/robot can use to monitor the Jet status. When the Jet is idle, the BusyFlag signal is set to high; when the Jet is activated, the BusyFlag signal is set to low. An external controller/robot can use the BusyFlag signal to synchronize the timing for the next Recipe trigger.

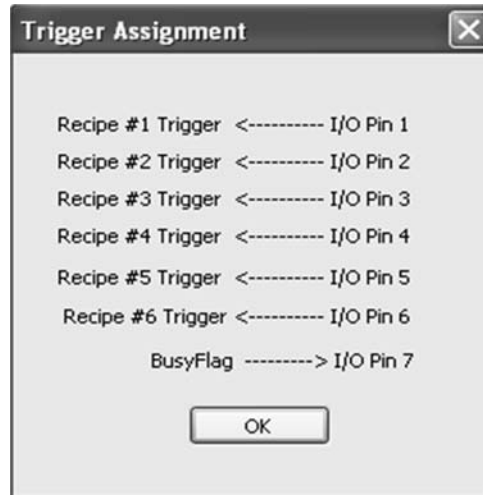

Figure 5-2: Trigger Map

7. **Download Settings:** Click on this button to download timing recipes, drop count, and trigger mode for the six recipes, and the settings for the temperature controller. The download command will overwrite the current settings in the controller.
8. **Heater Options:**
  - Heater On:** Sets the heater on the controller to ON or OFF.
  - Set temperature to:** Enters nozzle heater value (in degrees Celsius).
9. **Heater Off Timer:** This automatically turns off the heater after setting a specified Jet idle time in minutes. This feature is useful if materials will be adversely affected by long periods of heating. For example, some materials can be “cured” by high temperature when sitting in the nozzle chamber for a long period of idle time. A value of zero means the Heater Off timer option is not activated.

## 5.2 Settings Menu (Continued)

10. **RS-232 Settings:** The default settings for the Advanjet program and the controller are as follows:

SETTING	DEFAULT	OPTIONS
CTS (hardware handshake)	ON	ON or OFF
Baud Rate	57600	57600, 19200, 9600 or 4800
Parity	NONE	NONE, EVEN or ODD
Data Length	8BIT	8BIT or 7BIT

The Advanjet program sets the value for the **COM Port** at startup. The program polls each COM port in your computer and looks for the controller. Advanjet will warn the user if it fails to find the COM port for the controller. To troubleshoot, open Device Manager (Control Panel\System\Hardware\Device Manager) to view a list of hardware devices installed on your computer and properties for each device.

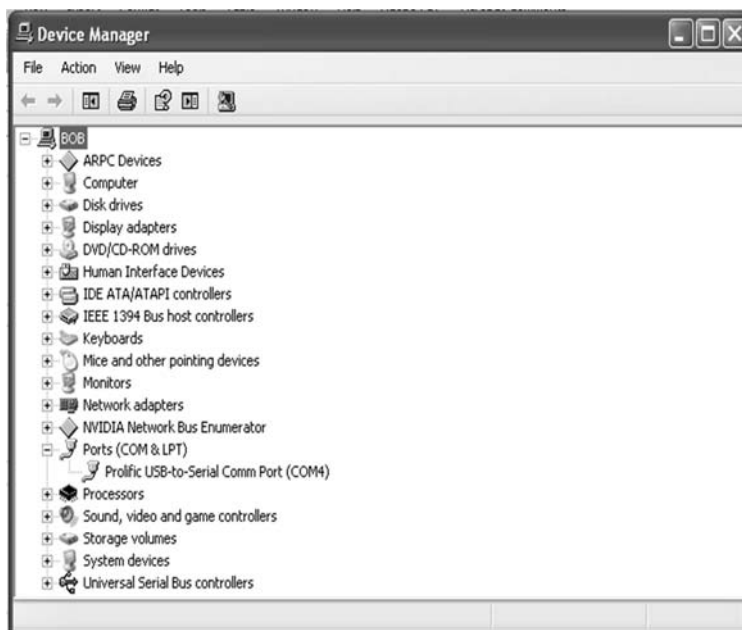

Figure 5-3: Assignment of COM Port Shown on Device Manager

- An entry for **Ports (COM & LPT)** will appear on the Device Manager list when a USB/Serial adapter cable is installed in the PC. For example, Figure 5-3 shows that the USB-to-Serial Com Port is assigned a value of 4 (COM4).
11. **Check Status:** Click on this button to check on the communication status between the Advanjet program and the controller. The status is displayed below the line on the left. A **Ready** status indicates that the communication is working. A **Com Port Error** or **Read Error** status indicates a RS-232 cable connection failure.



---

### 5.3 Running a Program from Software

---

Before running a program for the first time, make sure to check the following:

- Connect all electrical cables to the HV-2000. This includes the jet cable, the I/O cable if remote triggering is used, the RS-232 cable when running from the computer, and the power cable. All connections are unique.
- Turn ON the Advanjet controller. The heater controller and LCD display should indicate the system is active.
- Run the Advanjet software and make sure the main screen is active, the Controller Status shows Ready and the Jet button is RED.

When loading the Advanjet software, the Overwrite Warning shown in Figure 5-4 is presented as a reminder that any previous values set in the controller manually (using the front panel keys) will be reset. Be sure to note the jetting recipe values listed on the front panel LCD screen before choosing **Yes** to overwrite the settings.

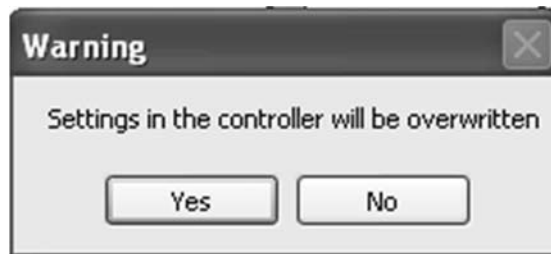

Figure 5-4: Overwrite Warning

**Note:** If this is the first time running the HV-2000, do not attempt to use remote triggering. Run the jet from the main Advanjet software screen.

- In the Settings menu, select **Recipe #1**. Set the timing to (2,8) (0.5, 0.8, 20), set the Count to 1, and set the Trigger Mode to PULSE.
- Park the HV-2000 Jet over a cup and push the **Jet** button on the main screen. The Button should turn from RED to BLUE. Material should flow through the feed tube and out the tip. It might take a while if the material is thick. If the material does not flow out the tip, heat is probably needed. A good starting temperature is 45 °C.
- Once material flows, the jet has been successfully primed and is ready to jet drops.

## 6. Timing Recipes

Before dispensing can begin, Timing Recipes must be created for the particular fluids being dispensed.

---

### 6.1 Timing Recipe Parameters

---

A Recipe specifies two timers, Refill Time and Dwell Time, which set the performance of the jet and the size and volume of the jetted drop. The values for Refill Time and Dwell Time depend on the rheology of the fluid to be dispensed and should be chosen to optimize jet performance and dispense quality.

**Refill Time** is the time that the jet is OPEN. The amount of refill time is dependent on viscosity, temperature, and fluid pressure. For example, for a UV adhesive with 1,000 cps, a typical **Refill** time might be from 1.7 to 2 msec with fluid pressure at 15 psi. It is best to determine the **Refill** time through application testing. Too much **Refill** time could cause accumulation of material on the nozzle tip. Not enough **Refill** time could result in a poor-quality drop or a missed drop.

Specifically, without sufficient **Refill** time, the jet will be “starved” and the drop size could be inconsistent. A pattern of large and small drops is usually a sign that the jet needs more time to refill. If this pattern is observed, increase the value of **Refill** time until the drops are consistent and stable. Alternatively, if a specific drop rate is desired, increase **Fluid Pressure** instead of **Refill** time.

**Dwell Time** is the time that the jet is CLOSED. In DROP mode, the value of **Dwell** time is usually not important since its duration is small compared to the motion time of the robot moving from one position to the next. However, in LINE mode, the **Dwell** time is important and sets the drop cycle time.

**Drop Cycle Time:** The following formula gives the relationship of drop cycle time, drop spacing, and robot velocity:

$$V = \Delta X / \Delta T$$

Where  $V$  = Robot Velocity  
 $\Delta X$  = Desired Drop Spacing  
 $\Delta T$  = Drop cycle time (Refill Time + Dwell Time).

**Refill+** and **Refill++** time: Refill time can be extended to give the jet a little extra time for the first drop to be ejected. This is useful with materials that are “shear thinning” and/or need a little extra time initially after being idle for a period of time. In either the DROP mode or LINE mode, the extra time is added to the Refill Time to adjust the time for the first drop.

## 6.2 Programming Timing Recipes

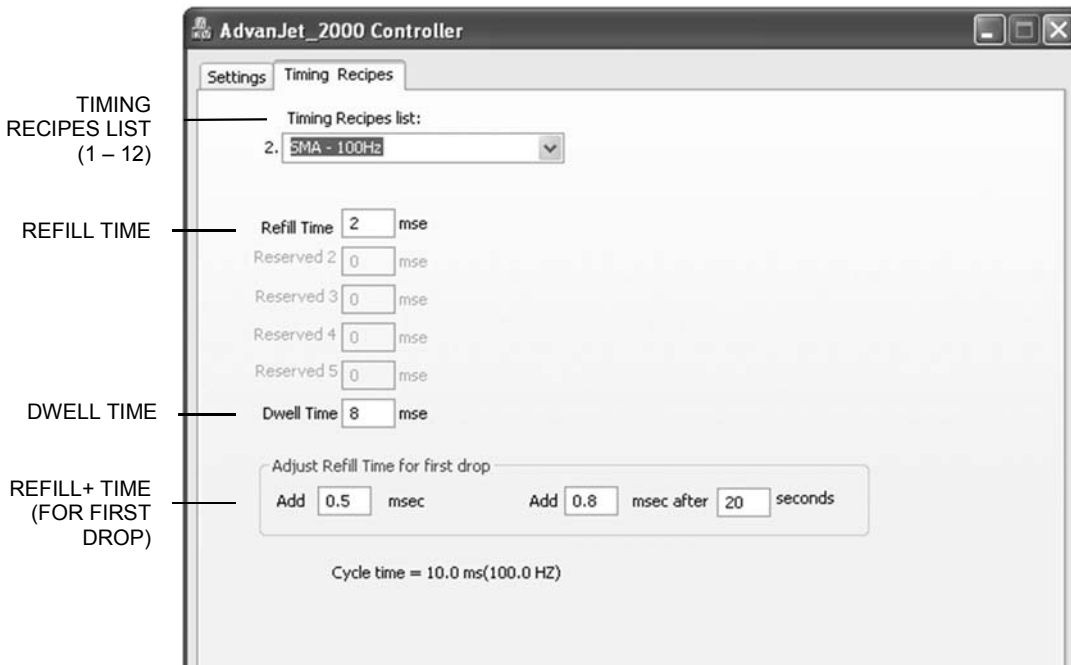

Figure 6-1: Timing Recipes Main Menu

The Advanjet software offers several sample Timing Recipes for popular fluids for a quick start-up. As shown in Figure 6-1 above, the Timing Recipes main menu screen lists the dispensing parameters on the HV-2000C controller front panel.

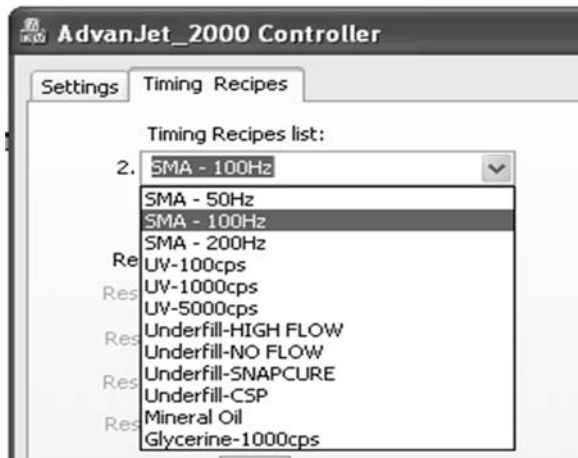

Figure 6-2: Timing Recipes List

**Timing Recipe List:** Up to twelve Timing Recipes can be programmed. Each Timing Recipe should have a distinct and unique name. Since these names will be used to identify fluid values and are used in the recipe list in the Settings screen, a good choice for a name is the specific fluid or material type (SMA-100Hz, UV-100 cps) or part number, as shown in Figure 6-2 at left.

---

## 6.2 Programming Timing Recipes (Continued)

---

**Refill Time:** Sets the time required for the material to flow into the orifice after each drop has been ejected. Time is set in msec with 0.1 msec resolution.

**Reserved 2 to Reserved 5:** These timers are not used for the HV-2000. They are set to zero by default.

**Dwell Time:** Sets the time required for the material to be ejected from the orifice. Time is set in msec with 0.1 msec resolution.

**Adjust Refill Time for First Drop:** There are two time values for adjusting the size and quality of the first drop. The programming is discussed here; a more detailed explanation is in Appendix 1: First Drop Compensation.

- **Add xxx msec:** is a time value that is added to Refill Time. Referring back to Figure 6-1, 2.0 msec (original Refill Time) + additional 0.5 msec = 2.5 msec Total Refill Time. In DROP mode, this value is added to every drop (described in Section 6.3). However, in LINE mode this value is added only to the very first drop (described in Section 6.4).

**Note:** this is the value of **Refill+** displayed on the LCD screen of the HV-2000C Controller (see Section 3.5).

- **Add XX msec after YY seconds:** is a time value added to the Refill Time after the jet is idled for a defined number of seconds. This additional time is added only to the first drop in both Drop and Line Mode. Referring again to Figure 6-1, the Refill Time for the first drop after 20 seconds at idle would be 2 msec (original Refill Time) + additional 0.8 msec = 2.8 msec Total Refill Time. This applies to only the first drop.

**Note:** this is the value of **Refill++** displayed on the LCD screen of the HV-2000C Controller (see Section 3.6). In general, the value of **Refill++** is slightly larger than **Refill +**.

**Note:** *Once the names and timing values have been chosen for a recipe, be sure to click the **APPLY** button to retain the changes.*

---

## 6.3 DROP Mode Programming

---

Programming the Advanjet system is very simple and flexible, as shown in the following examples.

### **Dispensing one drop at a time**

1. On the Settings Menu (see Section 5.2), select the pull-down menu to set the timing recipe for “Recipe #1”
2. Set the **Count** entry to 1 for “Recipe #1”
3. Set the **Trigger** Mode for “Recipe #1” to PULSE.
4. Click on “Download Settings” to send the new options to the controller.
5. The Robot moves to an X-Y position.
6. The Robot sends a trigger signal on I/O Pin 1 to the HV-2000C controller to jet a drop.
7. The Robot moves to another X-Y position.
8. The Robot sends a trigger to the controller to jet a drop, and so on.

### **Dispensing multiple drop sizes**

1. On the Settings Menu, select the pull-down menu to set the timing recipes for “Recipe #1” and “Recipe #2.”
2. Set the **Count** entry in “Recipe #1” to 1 for one drop.
3. Set the **Count** entry in “Recipe #2” to 2 for two drops.
4. Set the **Trigger** Mode for “Recipe #1” and “Recipe #2” to PULSE.
5. Click on “Download Settings” to send the new options to the controller.
6. The Robot moves to an X-Y position.
7. The Robot sends one trigger signal on I/O Pin 1 to the HV-2000C controller to jet one drop.
8. The Robot then moves to another X-Y position.
9. The Robot sends one trigger signal to I/O Pin 2 to the HV-2000C controller to jet two drops.

Alternately, instead of using two recipes as described above, the Robot can issue multiple triggers to I/O Pin 1 to fire multiple drops.

---

## 6.4 LINE Mode Programming

---

The Advanjet software and HV-2000C controller make dispensing lines very simple. The following examples illustrate how this is done.

### **Method 1: Jetting a line in PULSE mode**

1. Click on the Timing Recipes tab, select a Recipe # and enter a **Refill** time of 2 msec and **Dwell** time of 3 msec. (The timing is given here for illustration; exact timing for fluid and pressure varies with material.)
2. To dispense 60 drops in the line, click on the Settings tab and set **Count** to 60 and **Trigger** to PULSE.
3. For this example,  $\Delta X$  (drop spacing) is 0.5 mm and  $\Delta T$  (drop cycle time, which is Refill + Dwell time) is 5 msec/drop or 100 drops/second. To calculate the velocity (V) of the robot:
$$\begin{aligned} V &= \Delta X / \Delta T \\ &= 0.5 \text{ mm} / 0.005 \text{ sec} \\ &= 100 \text{ mm/sec} \end{aligned}$$
4. Click on Download Settings to send the new settings to the controller.
5. The Robot makes an XY move at 100 mm/sec and issues a trigger to I/O Pin 3. The Advanjet controller will jet 60 drops at 0.5 mm spacing.
6. To achieve smaller drops while maintaining the same velocity and  $\Delta X$ , change the Refill time to 1.7 msec and Dwell time to 3.3 msec to keep  $\Delta T$  at 5 msec.

### **Method 2: Jetting a line in LEVEL Mode**

1. Click on the Timing Recipes tab, select a Recipe # and enter a **Refill** time of 2 msec and **Dwell** time of 3 msec. The  $\Delta T$  (Refill + Dwell time) is 5 msec.
2. Click on the Settings tab and set **Trigger** to LEVEL. Note: in LEVEL mode, the controller ignores the **Count**. Instead, the number of drops to dispense is determined by the (time) duration of the 'low' trigger.
3. As determined above, drop cycle time ( $\Delta T$ ) is 5 msec. For drop spacing ( $\Delta X$ ) of 0.5 mm, robot velocity (V) is calculated as follows:
$$\begin{aligned} V &= \Delta X / \Delta T \\ &= 0.5 \text{ mm} / 0.005 \text{ sec} \\ &= 100 \text{ mm/sec} \end{aligned}$$
4. Click on Download Settings to send the new settings to the controller.
5. The Robot makes an X-Y move at 100 mm/sec and issues a trigger to I/O Pin 3. To jet 60 drops at the prescribed drop rate, this trigger signal should stay low for 300 msec (60 drops  $\times$  5 msec drop cycle time).
6. To dispense smaller drops at the same robot velocity and drop spacing, decrease **Refill** time to 1.7 msec and increase **Dwell** time to 3.3 msec (drop cycle time remains at 5 msec).

---

## 6.4 LINE Mode Programming (Continued)

---

### **Method 3: Jetting a line during an X-Y move**

There is another method to dispense a line if the Robot has the capability to issue triggers during an X-Y move. The Robot will make an X-Y move and send pulses of trigger to the controller at the position where it wants to jet a drop. The following example illustrates the procedure.

1. Click on the Timing Recipes tab, select a Recipe # and set the **Refill** time to 2 msec, **Dwell** time to 2.8 msec, **Count** to 1, and **Trigger** mode to PULSE.
2. Click on Download Settings to send the new settings to the controller.
3. The Robot makes an X-Y move.
4. The Robot sends a trigger to the controller every 5 msec to form a string of drops.

**Note:** *It is important to not issue a new pulse to the Advanjet controller until the  $\Delta T$  cycle is completed. Otherwise, the Advanjet controller will ignore the trigger if it hasn't completed its cycle. In the above example, Dwell Time was set to 2.8 msec to ensure the Advanjet cycle is completed before the robot issues a new pulse.*

## 7. Advanjet Controller Commands (ACC)

The ACC is a simple set of commands for controlling the Jet, timing values, and settings for the recipes. A host computer or external robot is connected to the Advanjet controller via an RS-232 cable. The host/robot sends ACC to the controller in ASCII format. This section serves as a reference for using ACC to write a custom program for the Advanjet Controller.

ADVANJET CONTROLLER COMMANDS (ACC)		
<b>RECIPE TIMING</b>		
<b>ST</b>	Set Recipe Timers	#RecipeID,#Refill,#0,#0,#0,#0,#Dwell;
<b>SL</b>	Adjust Refill Time for First Drop	#nRecipeID,#Refill+,#Refill++,#DelaySec;
<b>CT</b>	Set Drop Count and Trigger Format	#nRecipeID,#TriggerFormat,#nDotCount;
<b>JETTING</b>		
<b>SM</b>	Select Recipe	# nRecipeID;
<b>SG</b>	Start Dispensing	(no values required)
<b>SV</b>	Set Jet Value State	# nValveID,# nValveStatus;
<b>SD</b>	Reset Internal Drop Counter	#nDropcnt;
<b>HEATER</b>		
<b>SH</b>	Set Heater Temperature	# nTemperature;
<b>SO</b>	Turn Heater On/Off	# nFlag;
<b>HF</b>	Heater Off timer	# nMins;
<b>OUTPUT</b>		
<b>OD</b>	Output Internal Drop Counter	OD;
<b>OE</b>	Output Error	OE;
<b>OS</b>	Output Jet Status	OS;
<b>OT</b>	Output Temperature	OT;
<b>OV</b>	Output Version	OV;

### 7.1 The RS-232 Interface

The Advanjet controller is connected to the host computer/external robot via an RS-232 cable. The default settings for the controller are: CTS ON; Baud Rate 57600; Parity NONE; and Data Length set to 8BIT. To change the default RS-232 settings, refer to Section 4.2.

### 7.2 Command Format

Each command is identified by two ASCII characters (ST, SL, CT, etc.) and followed by a series of values. A COMMA separates each value and a SEMICOLON must terminate the last value. For example: **CT 0,0,2;** is a valid command. But **CT 0,0,2** is not valid because the controller is looking for a semicolon before executing this command.



### 7.3 Recipe Timing Commands

ST	Set Recipe Timers	#RecipeID,#Refill,#0,#0,#0,#0,#Dwell;
----	-------------------	---------------------------------------

The **ST** function configures the timing values for the recipe. #RecipeID numbers 0 to 5 correspond to Recipes 1 to 6.

#RecipeID 0	→	□□□□□□□□
#RecipeID 1	→	□□□□□□□2
#RecipeID 2	→	□□□□□□□3
#RecipeID 3	→	□□□□□□□4
#RecipeID 4	→	□□□□□□□5
#RecipeID 5	→	□□□□□□□6

Figure 7-1 - #RecipeID 0 – 5  
Corresponds to Recipe #1 - 6

Seven parameters are required for this function, defined as follows:

1	# nRecipeID	Identifies the recipe; it must be between <b>0 and 5</b> .
2	# Refill	Specifies the Refill Time in <b>0.1 msec</b> units.
3 - 6	#0, #0, #0, #0	Four reserved timer values; they must all be <b>0</b> .
7	# Dwell	Specifies the Dwell Time in <b>0.1 msec</b> units.

Example #1: ST 0,18,0,0,0,0,32;

Sets the first recipe, Recipe #1

Refill Time is 1.8 msec

Dwell Time is 3.2 msec

The Refill Time plus the Dwell Time set the single drop cycle time to 5msec (1.8 +3.2) resulting in a drop frequency of 200 drops per second.

Example #2: ST 3,50,0,0,0,0,150;

Sets Recipe #4

Refill Time is 5 msec

Dwell Time is 15 msec

The Refill Time plus the Dwell Time set the single drop cycle time to 20msec (5+15) resulting in a drop frequency of 50 drops per second

### 7.3 Recipe Timing Commands (Continued)

<b>SL</b>	Adjust Refill Time for First Drop	#nRecipeID,#Refill+,#Refill++,#DelaySec;
-----------	-----------------------------------	--

The **SL** command adjusts the Refill Time for the first dot. These values help to control the size and quality of the first dot. Four parameters are required for this function, defined as follows:

1	# nRecipeID	Identifies the recipe; it must be between <b>0 and 5</b> .
2	# Refill+	Sets the timing value in <b>0.1 msec</b> units to be added to the first dot
3	# Refill++	Sets the timing value in <b>0.1 msec</b> units to be added to the first dot after the Jet is idle for # DelaySec seconds
4	# DelaySec	Sets the Jet idle time used by the #Refill++ in <b>seconds</b> .

**Example:** SL 0,2,4,20;

Sets the first recipe, Recipe #1

Refill+ Time is 0.2 msec

Refill++ Time is 0.4 msec

Idle Time is 20 seconds

The Refill+ Time (0.2 msec) is added to the Refill Time of Recipe #1 for every drop in DROP mode and added only to the very first drop in LINE mode, as described in Section 6.4. If the Jet has been idle for more than 20 seconds, then the Refill++ Time (0.4 msec) is used for first drop adjustment.

<b>CT</b>	Set Drop Count and Trigger Format	#nRecipeID,#TriggerFormat,#nDotCount;
-----------	-----------------------------------	---------------------------------------

The **CT** command set the count value for drops and the format for the trigger input. Three parameters are required for this function, defined as follows:

1	# nRecipeID	Identifies the recipe; it must be between <b>0 and 5</b> .
2	# TriggerFormat	Sets #TriggerFormat; 0 = PULSE and 1 = LEVEL
3	# nDotCount	Sets the number of drops per trigger signal

**Example #1:** CT 0,0,2;

Sets the first recipe, Recipe #1

Trigger format is PULSE

Drop Count is 2.

This command will cause the Jet to dispense 2 drops when it receives a PULSE signal from Recipe #1 Trigger.

**Example #2:** CT 1,1,5;

Sets the second recipe, Recipe #2

Trigger format is LEVEL

The number of drops will depend on the duration of the LEVEL signal (low) from Recipe #2 Trigger and the single drop cycle time defined by the ST command. The drop count value of 5 is ignored.

### 7.4 Jetting Commands

<b>SM</b>	Select Recipe	# nRecipeID;
-----------	---------------	--------------

The **SM** command identifies the recipe that the controller should use when it receives a **SG** (start dispensing) command from the host/robot. This command should be sent before an **SG** command to identify the recipe timers and settings.

# nRecipeID	Identifies the recipe; it must be between <b>0 and 5</b> .
-------------	--

Example:     **SM 3;** selects Recipe #4

<b>SG</b>	Start Dispensing	(no values required)
-----------	------------------	----------------------

The **SG;** command will cause the controller to activate the Jet. The SM command must be used to identify the recipe for timing values and the number of drops to dispense. The SG command must be followed by a semicolon.

Example: Here is a sequence of commands sent to the controller to program Recipe#1 and Recipe#2 before dispensing:

```
ST 0,50,0,0,0,0,100;
SL 0,2,4,20;
CT 0,0,1;
ST 1,50,0,0,0,0,150;
SL 1,2,4,20;
CT 1,0,2;
```

The **CT** command sets one drop to dispense for Recipe#1 and two drops for Recipe#2. When the external host moves to an XY position, it might send the following commands to dispense one drop using the values setup in Recipe#1:

```
SM 0;
SG;
```

The host then moves to another XY position and sends another **SG;** command to dispense another drop at the new location. It can keep on doing this as long as it is using the values in Recipe#0. If the host decides to dispense 2 drops at the new location, it should send an **SM 1;** command to select Recipe#1 before issuing a **SG;** command.

---

## 7.4 Jetting Commands (Continued)

---

<b>SV</b>	Set Jet Value State	# nValveID,# nValveStatus;
-----------	---------------------	----------------------------

This command allows the host to open or close the Jet valve.

1	# nValveID	Sets # nValveID to <b>0</b> for Jet valve
2	# nValveStatus	Sets # nValveStatus; <b>1</b> = open and 0 = closed

Example:    **SV 0,1;** opens the Jet.

<b>SD</b>	Reset Internal Drop Counter to 0	#nDropcnt;
-----------	----------------------------------	------------

This command is used to reset the internal drop counter to zero

#nDropcnt	Resets the internal drop counter.
-----------	-----------------------------------

Example:    **SD 0;** resets the internal drop counter to 0.

---

## 7.5 Heater Commands

---

<b>SH</b>	Set Heater Temperature	# nTemperature;
-----------	------------------------	-----------------

The **SH** command allows the host to set the temperature for the Heater Controller in the Advanjet Controller.

# nTemperature	Sets temperature value in <b>degrees Celsius</b> . This value should be <b>less than 75</b> degrees Celsius (167 °F).
----------------	--

<b>SO</b>	Turn Heater On/Off	# nFlag;
-----------	--------------------	----------

The **SO** command allows the host to turn On or Off the heater in the controller.

# nFlag	Sets #nFlag; 1 = turn heater on and 0 = turn heater off
---------	---

<b>HF</b>	Heater Off timer	# nMins;
-----------	------------------	----------

The **HF** command gives the host the ability to automatically turn the heater off after a specified Jet idle time.

# nMins	Sets the idle Jet time in <b>minutes</b>
---------	--

Example: The following commands will set the heater temperature to 50 degree Celsius (122 °F), the idle time to 5 minutes and turn on the heater.

```
SH 50;  
HF 5;  
SO 1;
```

---

## 7.6 Output Commands

---

<b>OD</b>	Output Internal Drop Counter	OD;
-----------	------------------------------	-----

The host can send the **OD;** command to determine the number of drops that have been completed since the last **SD;** command (reset counter command). A return string consisting of the total number of drops will be returned.

<b>OE</b>	Output Error	OE;
-----------	--------------	-----

The host can send the **OE;** command to verify that it is communicating properly with the controller. A return string of **0;** indicates that the command was received without error and **1;** indicates there was an error in the previous command. Once the **OS;** command return string is returned, the error state in the controller is cleared.

<b>OS</b>	Output Jet Status	OS;
-----------	-------------------	-----

The host can send the **OS;** command to verify that it is communicating properly with the controller. A return string of **1;** indicates that the Jet valve is closed and **0;** indicates the valve is opened.

<b>OT</b>	Output Temperature	OT;
-----------	--------------------	-----

The host can send this **OT;** command to get the present temperature of the Jet heater. A return string of **50.5;** indicates the temperature is at 50.5 degree Celsius.

<b>OV</b>	Output Version	OV;
-----------	----------------	-----

The host can send this **OV;** command to identify the controller. A return string of **ADV-HV2000P\_xxxx** indicates that the host has found the controller.

**Note:** *The controller might not be able to respond to the output commands when it is busy dispensing a long series of drops. In this case, the host should try again after a short wait.*

## Appendix 1: First Drop Compensation

### Appendix 1-1: Background

Many viscous fluids are thixotropic and their viscosity decreases with motion. This is often referred to as shear thinning. When dispensing a thixotropic fluid, the very first drop ejected is often smaller than subsequent drops if the jet has been idle for some time.

Traditionally, operators dispense a few “wasted drops” in a blank area of the substrate to get the dispensing material into a shear-thinning condition. Although this technique is a good idea because it gets rid of the first drop problem altogether, it wastes time and fluid. The Advanjet HV-2000C has a better solution.

### Appendix 1-2: Calculating First Drop Compensation

To compensate for small first drops, the HV-2000C offers two jetting parameters: **Refill +** and **Refill ++**. The first drop compensation process is based on the following:

$T^+$  = First Drop Compensation  
 $T^{++}$  = Extended Drop Compensation  
Elapse Time = Idle time of the jet since the last dispense  
Extended Timeout = Time entered in the Recipes Menu/Adjust Refill Time for first drop “msec after YY seconds”

If Elapse Time < Extended Timeout, then Refill Time = Refill +  $T^+$   
If Elapse Time > Extended Timeout, then Refill Time = Refill +  $T^{++}$

Examples: For a time-cure material, the fluid could be slightly thickening if it sits idle for a long time, especially if the fluid is being actively heated. Suppose Extended Timeout is set at 20 seconds. The first drop refill time will equal (Refill +  $T^*$ ), where the value of  $T^*$  depends on how long the jet has been idle.

If Elapse Time < 20 sec (Extended Timeout), then  $T^* = T^+$   
If Elapse Time  $\geq$  20 sec (Extended Timeout), then  $T^* = T^{++}$

Lines: For the first drop of all the lines, Refill Time = Refill +  $T^{++}$ . Subsequent drops will have a Refill Time without any compensation if multiple drops are specified.

Individual Drops: For individual drops, Refill Time = Refill +  $T^+$ . When dispensing individual drops with an Elapse Time of less than 20 seconds, the compensation is always applied.

### Appendix 1-3: First Drop Compensation in PULSE Mode

- In this mode, the controller produces “n” drops when it receives a trigger signal, where “n” is the number of drops.
- Refill Time for the first dot = Refill +  $T^+$
- Refill Time for all subsequent dots = Refill (no added first drop compensation)
- If the number of drops is set to 1, the refill time will always be Refill +  $T^+$  because there are no subsequent dots.

Example 1: Number of drops = 1

In the timing diagram below,  $T^* = T^+$   
Therefore, each drop = Refill +  $T^+$

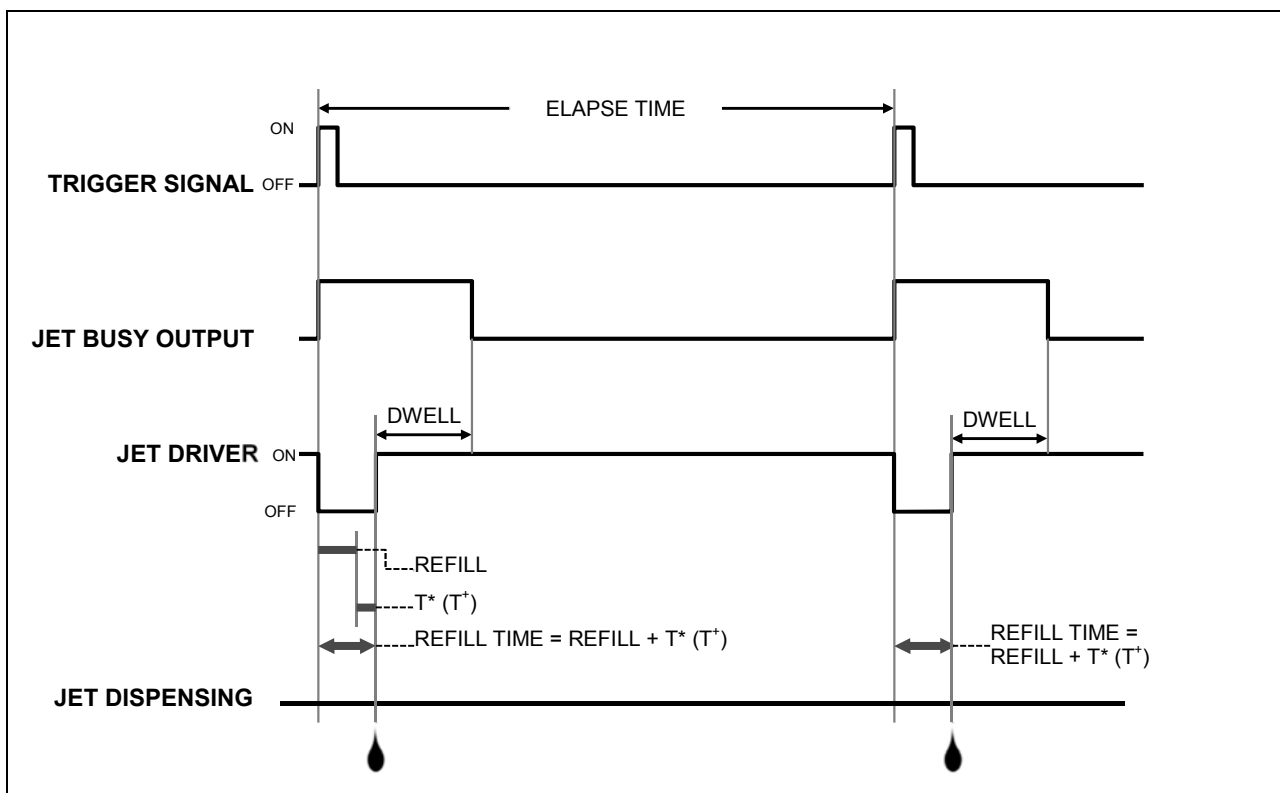

Figure A1- 1: 1<sup>st</sup> Drop Compensation in PULSE Mode, # of Drops = 1



### Appendix 1-3: First Drop Compensation in PULSE Mode (Continued)

Example 2: Number of drops = 3

In the timing diagram below,  $T^* = T^+$

Therefore, the first drop = Refill +  $T^+$

The refill time for all other drops = Refill (no first drop compensations added).

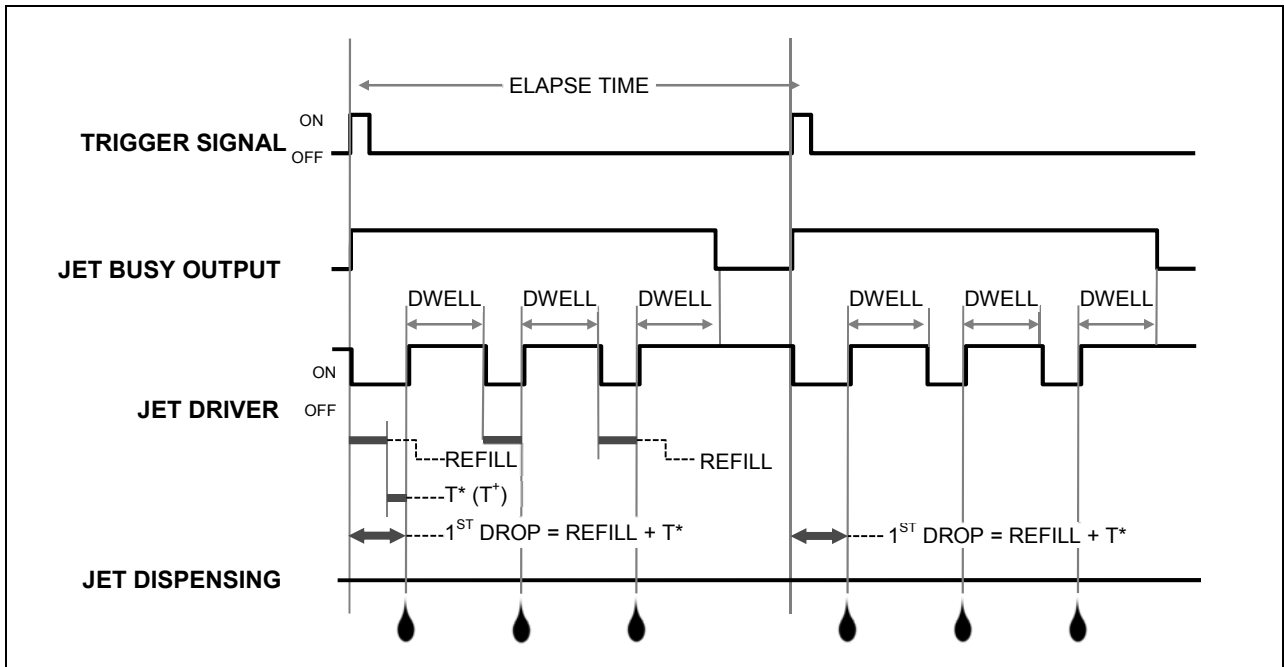

Figure A1- 2: 1<sup>ST</sup> Drop Compensation in PULSE Mode, # of Drops = 3

## Appendix 1-4: First Drop Compensation in LEVEL Mode

- In this mode, the controller produces drops as long as the Trigger signal is high
- Refill Time for the first dot = Refill +  $T^*$
- Refill Time for all other dots = Refill

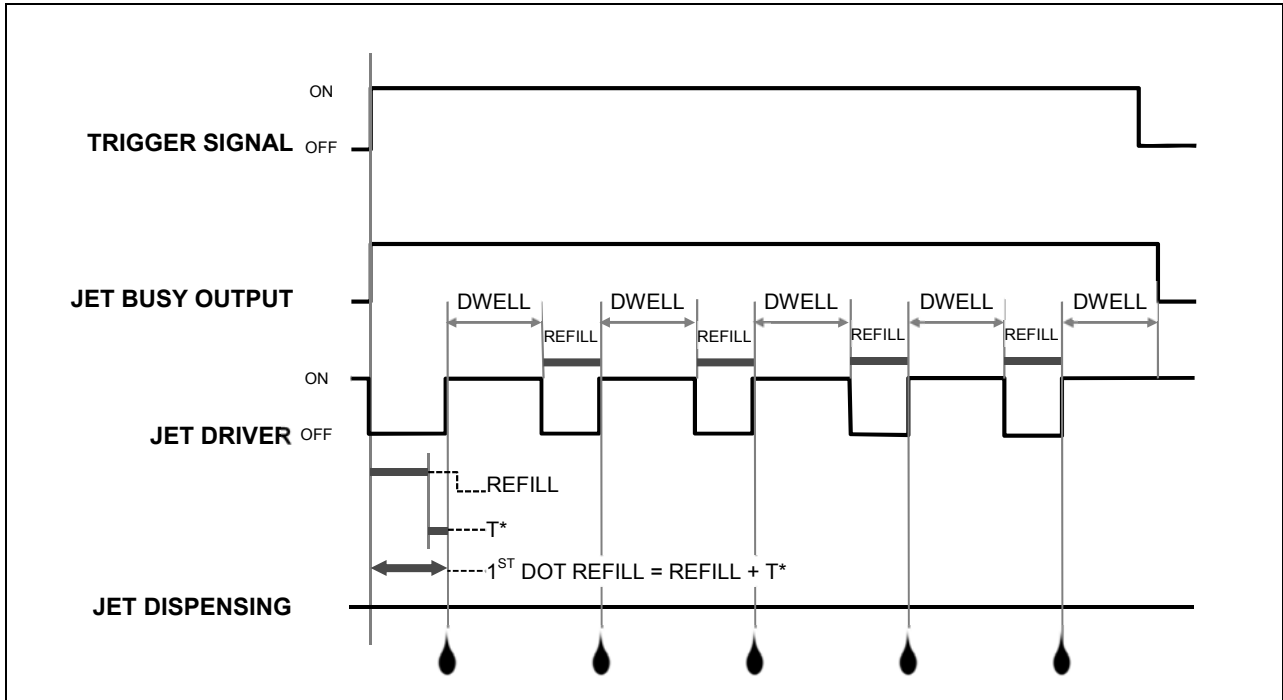







Figure A1- 3: 1<sup>st</sup> Drop Compensation in LEVEL Mode, # of Drops = 1

## Appendix 2: Temperature Controller Factory Settings

The CN740 Temperature Controller manual is included with your Advanjet controller shipment. Please refer to it for specific instructions.

Listed below are factory set values programmed by Advanjet to work with the HV-2000C controller and the HV-2000 Jet Nozzle plate for the majority of applications. It is strongly recommended that users do not modify these values.

Use the  keys to adjust values. Press  once to save changes, and press  again to return to the previous menu.

OPERATION	Description	Setting	Value
Press 	Control Run/Stop setting	r-S	
	Upper-limit alarm 1	AL1H	3
	Lower-limit alarm 1	AL1L	3
	Upper-limit alarm 2	AL2H	3
	Lower-limit alarm 2	AL2L	3
		LOC	oFF
REGULATION	Description	Setting	Value
Press  once, then press 	PB (Proportional band)	P	4
	Ti (Integral time)	i	20
	Td (Derivative time)	d	5
	Default value of Integral Volume	ioF	0
	Heating Control Cycle Setting	HtPd	10
	Process Temperature Offset	tPoF	0
INITIAL SETTINGS	Description	Setting	Value
Press and hold 	Input temperature sensor type	inPt	Pt2
	Temperature unit display selection	tPUn	C
	Upper-limit of temperature range	tP-H	75
	Lower-limit of temperature range	tP-L	-20
	Control method	Ctrl	PiD
	Heating/Cooling control Selection	S-HC	HEAt
	Alarm 1 type	ALA1	1
	Alarm 2 type	ALA2	1
	Data Format	C-5L	ASCII
	Communication write-in selection	Co5H	on
	Controller Address	C-no	1
	Baud Rate Setting	bP5	9600
	Communication Data Length	LEn	8
	Communication Parity Bit	Prty	nonE
Communication Stop Bit	Stop	1	

## Appendix 3: Digital Pressure Gauge

### Appendix 3-1: Specifications

**KEYENCE**

AP-30 Series  
Two-Color Digital Display Pressure Sensor



TYPE	NEGATIVE PRESSURE		POSITIVE PRESSURE		COMPOUND PRESSURE
	Model	AP-31K (P)	AP-32K (P)	AP-33K (P)	AP-34K
Rated pressure	0 to -29.9 inHg (0 to -101.3 kPa)	0 to 14.50 psi (0 to 100 kPa)	0 to 145.0 psi (0 to 1.000 MPa)	29.9 to -29.9 inHg (101.3 to -101.3 kPa)	
Pressure resistance	72.5 psi	72.5 psi	217.5 psi	72.5 psi	
Type of pressure	Gauge pressure, air or non-corrosive gases				
Fluid type	Air or non-corrosive gases				
Display power	3 1/2-digit, 2-color, 7-segment LED (Character height: 11 mm 0.43")				
Display resolution	0.1 kPa, 1 mmHg, 0.1 inHg, 0.001 bar	0.1 kPa, 0.001 kgf / cm <sup>2</sup> , 0.02 psi, 0.001 bar	0.001 MPa 0.01 kgf / cm <sup>2</sup> , 0.2 psi, 0.01 bar	0.2 kPa, 2 mmHg, 0.1 inHg, 0.002 bar	
Display range	-15% to +110% of F.S.				
Repetition accuracy	±0.2% of F.S. (5 ms or more)				
Response time (chatter prevention function)	2.5/5/100/500 ms (selectable)				
Control output	NPN open collector: 100 mA max. (40 V max.), Residual voltage: 1 V max. 2-output (N.O./N.C.selectable)				
Analog output	1 to 5 V (Load impedance: 47 kΩ min.)				
Temperature fluctuation for analog output	±2% max. (of F.S.) of detecting pressure at 25 °C (77°F) (0 to 50 °C) (32 to 122 °F)				
Temperature fluctuation for display	±1% max. (of F.S.) of detecting pressure at 25 °C (77°F) (0 to 50 °C) (32 to 122 °F)				
Control output hysteresis	Variable (when hysteresis mode is selected), 0.5% of F.S. in standard mode				
Power supply	12 to 24 VDC ±10%				
Current consumption	50 mA (at 24 V), 90 mA (at 12 V)				
Ambient temperature	0 to 50 °C (32 to 122°F), No condensation / 35 to 85% RH (No condensation)				
Relative humidity	35 to 85% RH (No condensation)				
Vibration	10 to 55 Hz, 1.5 mm 0.06" double amplitude in X, Y, and Z directions, 2 hours respectively				
Material	Front housing: Polyamide, Front panel sheet: PET, Rear housing: Polysulfone, Pressure port: Die-cast zinc, Cable: Oil-proof cabtyre cable				
Weight	Approx. 120 g				

---

## Appendix 3-2: Part Names and Functions

---

### AUTO key

In auto-tuning mode, use this key to detect pressure. In measurement mode, press this key for 2 seconds or more to adjust the zero-point.

### SET key

Use this key to display or change preset values.

### Output indicator 2 (Green LED)

### Display unit label

### Output indicator 1 (Red LED)

### UP/DOWN key

Use these keys to set output modes, or to change preset values or units.

### Housing

### Hexagonal socket bolt

### Rear metal casing (Die-cast zinc)

## ■ Display unit label

The AP-30 series enables you to select the display units for pressure. Attach the included display unit label for the desired units at the  position in the figure.

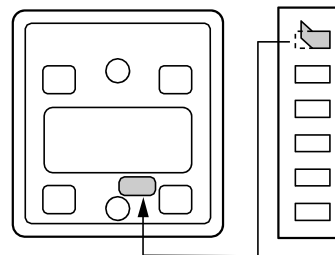

## Appendix 3-3: Connections and Input/Output Circuit

### ■ Connections

- Drive current load

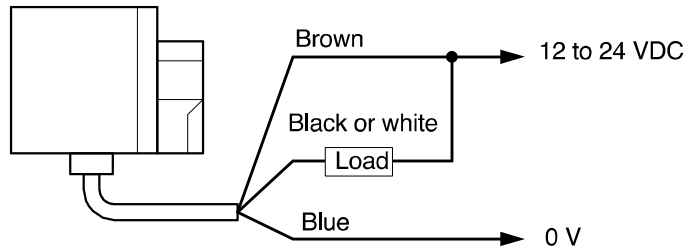

- Input to voltage input equipment

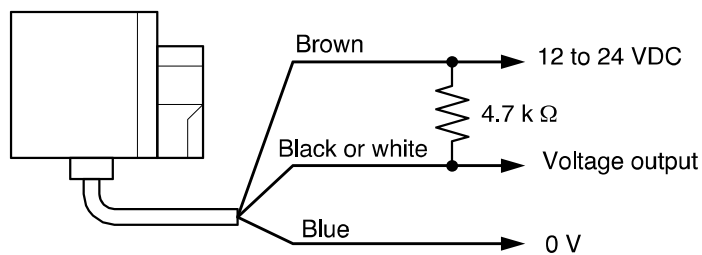

### ■ Input/output circuit

- Output circuit

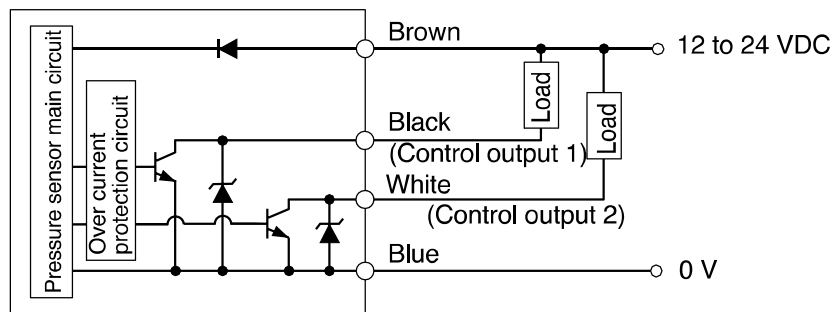

#### AP-31Z/32Z/33Z/34Z (Z type only)

Input circuit (Zero-shift input)  
Zero-shift input resets the display to "0" at the rising edge of the signal.

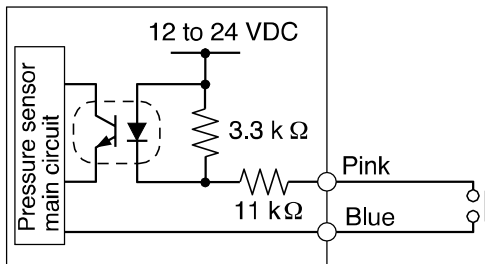

#### AP-31/32/33/34 (Except for Z type)

Analog output circuit

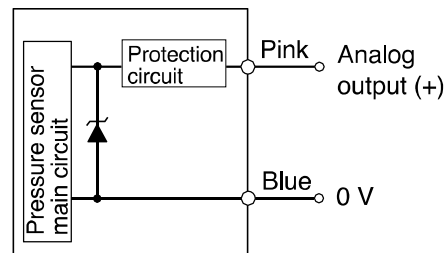

## Appendix 3-4: Operation Mode Selection

### ■ Auto-tuning mode (F-1)

Using the AUTO key, detect the upper limit value (A) and the lower limit value (b). The detection level (C) is automatically set at the midpoint between the two values. (You can finely adjust the preset value C within the range between A and b.)

Control output 1: The sensor turns on when the pressure exceeds the preset value C.

Control output 2: The sensor turns on when the pressure goes outside the stability levels.

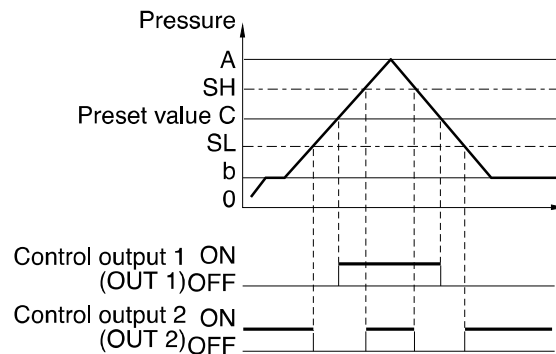

\* The stability levels are automatically set as shown in the following calculations.

$$SH = \frac{A + C}{2}$$

$$SL = \frac{C + b}{2}$$

### ■ Hysteresis mode (F-2)

Set desired detection level (H) and hysteresis (h) for the detection.

Control output 1: The sensor turns on when the pressure exceeds the preset value H. When the pressure falls by the preset value h, the sensor turns off.

Control output 2: The sensor turns on when the pressure goes outside the hysteresis width (H - h).

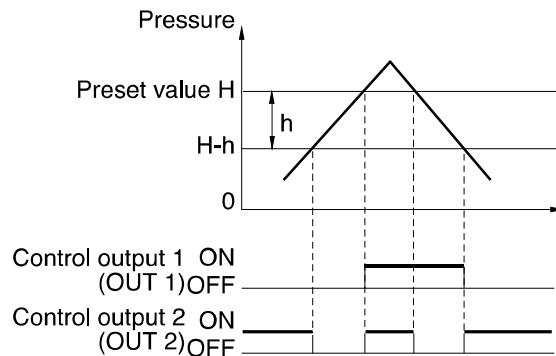

h: Hysteresis width of OUT1

\* When h is set to a value close to 0, if pressure fluctuates around the detection point, OUT1 will chatter.

---

## Appendix 3-5: Operation Mode Selection

---

### ■ 2-independent mode (F-3)

Set two desired detection points (A and B).

Control output 1: The sensor turns on when the pressure exceeds the preset value A.

Control output 2: The sensor turns on when the pressure exceeds the preset value b.

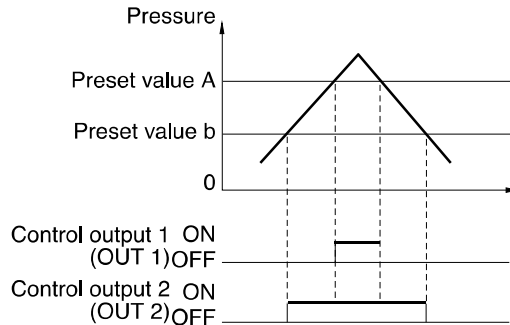

### ■ Window mode (F-4)

Set desired upper limit value (H) and lower limit value (L).

Control output 1: The sensor turns off when the pressure goes outside of the range between the upper limit value (H) and lower limit value (L).

Control output 2: The sensor turns off when the pressure goes outside of the stability levels.

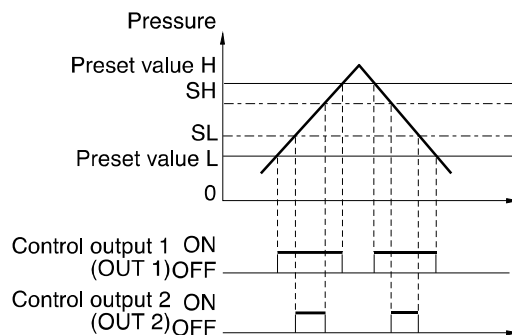

\* The stability levels are automatically set as shown in the following calculations.

$$SH = H - \frac{(H - L)}{4}$$

$$SL = L + \frac{(H - L)}{4}$$

**Note 1:** The above description shows the operation of control outputs 1 and 2 when the output selector switch is set to N.O.

When the output selector switch is set to N.C., the operation of control outputs 1 and 2 is inverted.

**Note 2:** Except for OUT1 in hysteresis mode, each control output includes an internal hysteresis of 0.5% of F.S.

---



## Appendix 3-6: Adjustment

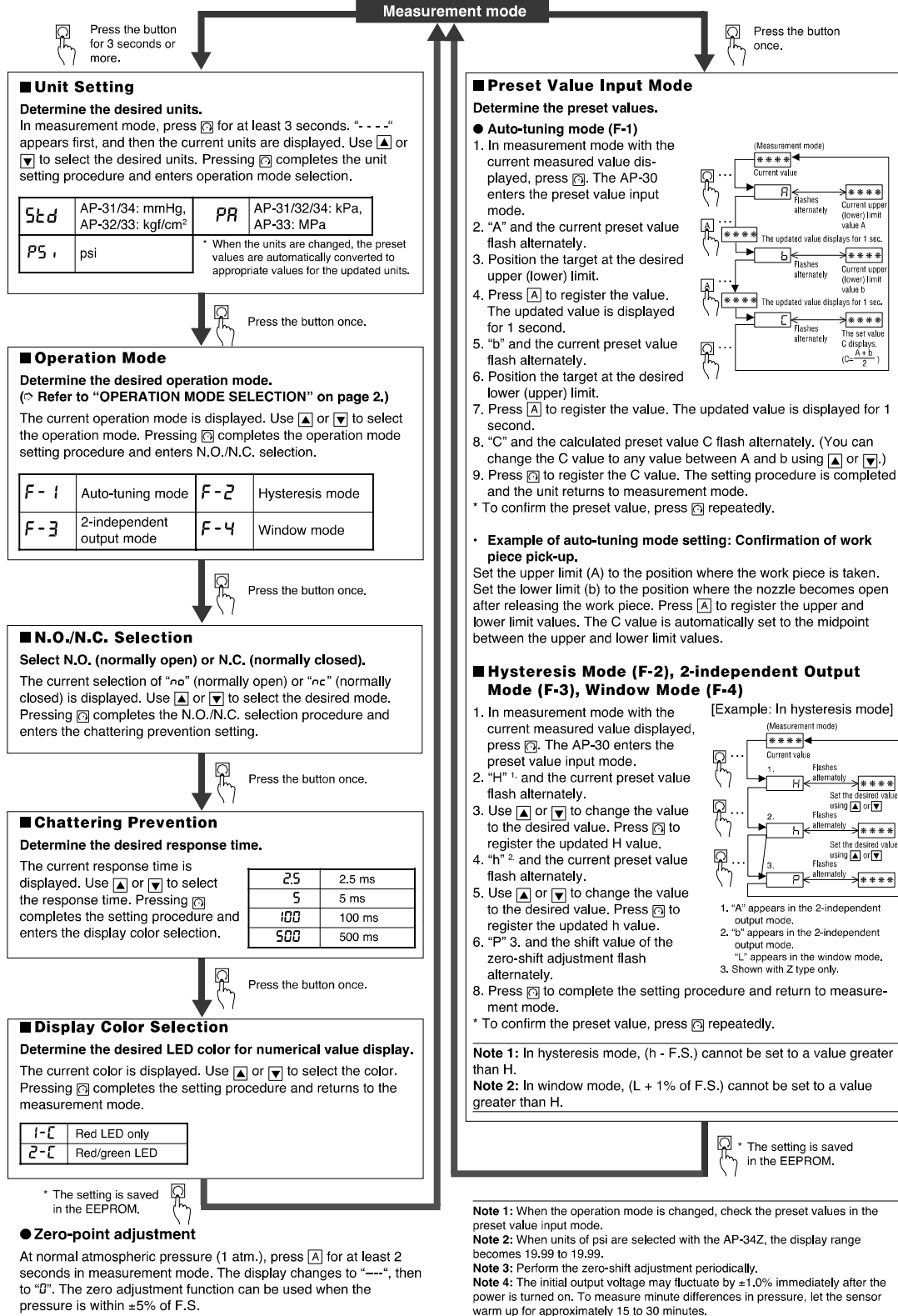

## Appendix 3-7: Other Functions and Error Indications

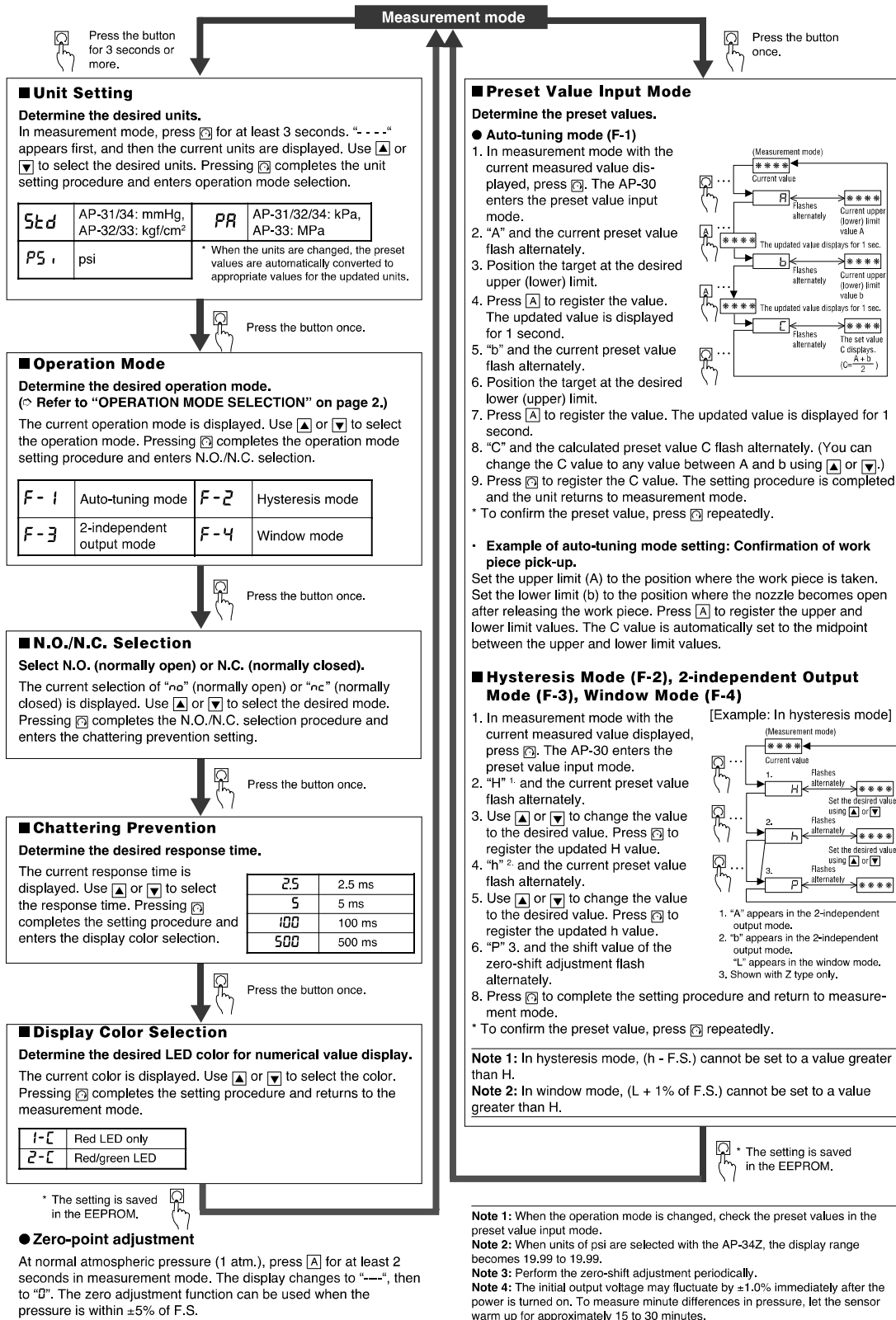

## Appendix 4: Input/Output Connector

The HD26 I/O connector connects to one type of input circuit and four types of output circuits. The design notes suggest at least one interface circuit on the user's side of each type of input or output.

As a general rule, a good interface should provide level shifting and galvanic isolation between the jet controller and the robot. Galvanic isolation enhances noise immunity between the jet controller and the robot.

For true galvanic isolation when using opto-isolators, it is necessary to use two independent power supplies, one on the input side, and one on the output side. If the input-side ground is connected to the output-side ground, or if there is only one power supply, there is no ground isolation, and the "opto-isolator" is reduced in functionality to a simple level shifter.

---

### Appendix 4-1: HD26 Pin Assignments

---

A standard 5-foot I/O cable is supplied with the HV-2000C. The I/O is configured for the inputs to be pulled down to GND. When the specific input is triggered, the Advanjet controller will activate the corresponding preprogrammed Recipe # shown.

- Pins 1 through 6 of the I/O cable are outputs from the robot to the Advanjet controller. They can be TTL outputs capable of sinking 2 mA of current, or they can also be relay contacts.
- Pin 7 outputs a busy status flag from the Advanjet controller to the robot.
- Pin 8 is an external interrupt used to remotely stop a dispensing program
- Pins 9 and 14 are Isolated Ground
- Pins 18-26 are alarms from the heater and pressure sensors.

The tables that follow describe the pin assignments of the standard 26-pin I/O connector; the pin name, terminology and specifications; and the corresponding schematic diagram.

## Appendix 4-1: HD26 Pin Assignments (Continued)

HD26 Pin Number	HV-2000C Pin Name, Terminology, Specifications	Schematic
1	Recipe 1 (Input) Bit 0, DIO 16. Digital input 0–5 V DC, switching threshold 1.4 V/1.9 V typical. Input is normally high. Assert by pulling low.	Configurable I/O DIO0- DIO31
2	Recipe 2 (Input) Bit 1, DIO 17. Digital input 0–5 V DC, switching threshold 1.4 V/1.9 V typical. Input is normally high. Assert by pulling low.	Configurable I/O DIO0- DIO31
3	Recipe 3 (Input) Bit 2, DIO 18. Digital input 0–5 V DC, switching threshold 1.4 V/1.9 V typical. Input is normally high. Assert by pulling low.	Configurable I/O DIO0- DIO31
4	Recipe 4 (Input) Bit 3, DIO 19. Digital input 0–5 V DC, switching threshold 1.4 V/1.9 V typical. Input is normally high. Assert by pulling low.	Configurable I/O DIO0- DIO31
5	Recipe 5 (Input) Bit 4, DIO 20. Digital input 0–5 V DC, switching threshold 1.4 V/1.9 V typical. Input is normally high. Assert by pulling low.	Configurable I/O DIO0- DIO31
6	Recipe 6 (Input) Bit 5, DIO 21. Digital input 0–5 V DC, switching threshold 1.4 V/1.9 V typical. Input is normally high. Assert by pulling low.	Configurable I/O DIO0- DIO31
7	Busy Flag (Output) Bit 6, DIO 22. Digital output 5 V, 2 mA. When the Jet is idle, the BusyFlag signal is set to high; when the Jet is activated the BusyFlag signal is set to low.	Buffered A/D Converter Inputs
8	External Interrupt (Input) DIO 11, Digital input 0–5 V DC, switching threshold 1.4 V/1.9 V typical. Input is normally high. Assert by pulling low.	Buffered A/D Converter Inputs
9	GND DIGITAL GROUND	Buffered A/D Converter Inputs
10	Analog Output AOUT 0 12-bit res. channel, buffered, 0–10 V DC, $\pm 10$ VDC, and 4–20 mA, update rate 12 kHz.	D/A Converter Outputs

## Appendix 4-1: HD26 Pin Assignments (Continued)

Pin Number	HV-2000C Pin Name, Terminology, Specifications	Schematic
11	Analog input AIN 5 11-bit res. channel, software-selectable ranges unipolar: 1, 2, 2.5, 5, 10, 20 V DC; bipolar $\pm 1$ , $\pm 2$ , $\pm 5$ , $\pm 10$ V DC; 4 channels can be hardware-configured for 4–20 mA; 1 M $\Omega$ input impedance, up to 4,100 samples/s	Buffered A/D Converter Inputs
12	Analog Input AIN 7 11-bit res. channel, software-selectable ranges unipolar: 1, 2, 2.5, 5, 10, 20 V DC; bipolar $\pm 1$ , $\pm 2$ , $\pm 5$ , $\pm 10$ V DC; 4 channels can be hardware-configured for 4–20 mA; 1 M $\Omega$ input impedance, up to 4,100 samples/s.	Buffered A/D Converter Inputs
13	Analog output AOUT 1 12-bit res. channel, buffered, 0–10 V DC, $\pm 10$ VDC, and 4–20 mA, update rate 12 kHz.	D/A Converter Outputs
14	GND ANALOG GROUND	
15-16-17	No connection.	
18	Heater Alarm Common (Output)	
19	Fluid Pressure Alarm Common (Output) Optional alarm. Not normally programmed for use.	Pressure Alarm Input/Output Circuit (AP-C30K/C31K/C33K)
20	Fluid Pressure Alarm 2 (Output) Optional alarm. Not normally programmed for use.	
21	Fluid Pressure Alarm 1 (Output) Optional alarm. Not normally programmed for use.	
22	Jet Pressure Alarm Common (Output) Optional alarm. Not normally programmed for use.	
23	Jet Pressure Alarm 2 (Output) Optional alarm. Not normally programmed for use.	
24	Jet Pressure Alarm 1 (Output) Optional alarm. Not normally programmed for use.	
25	Heater Alarm 1 (Output) Single Pole, Single Throw, Normally open relay contact, 3A, 250 VAC. When closed, pin 25 is connected to pin 18, Heater Alarm Common. Optional alarm. Not normally programmed for use. May be configured to create an alarm for 12 different fault conditions.	
26	Heater Alarm 2 (Output) Single Pole, Single Throw, Normally open relay contact, 3A, 250 VAC. When closed, pin 26 is connected to pin 18, Heater Alarm Common. Optional alarm. Not normally programmed for use. May be configured to create an alarm for 12 different fault conditions.	

**Appendix 4-2: Schematic for Configurable I/O DIO0-DIO31**

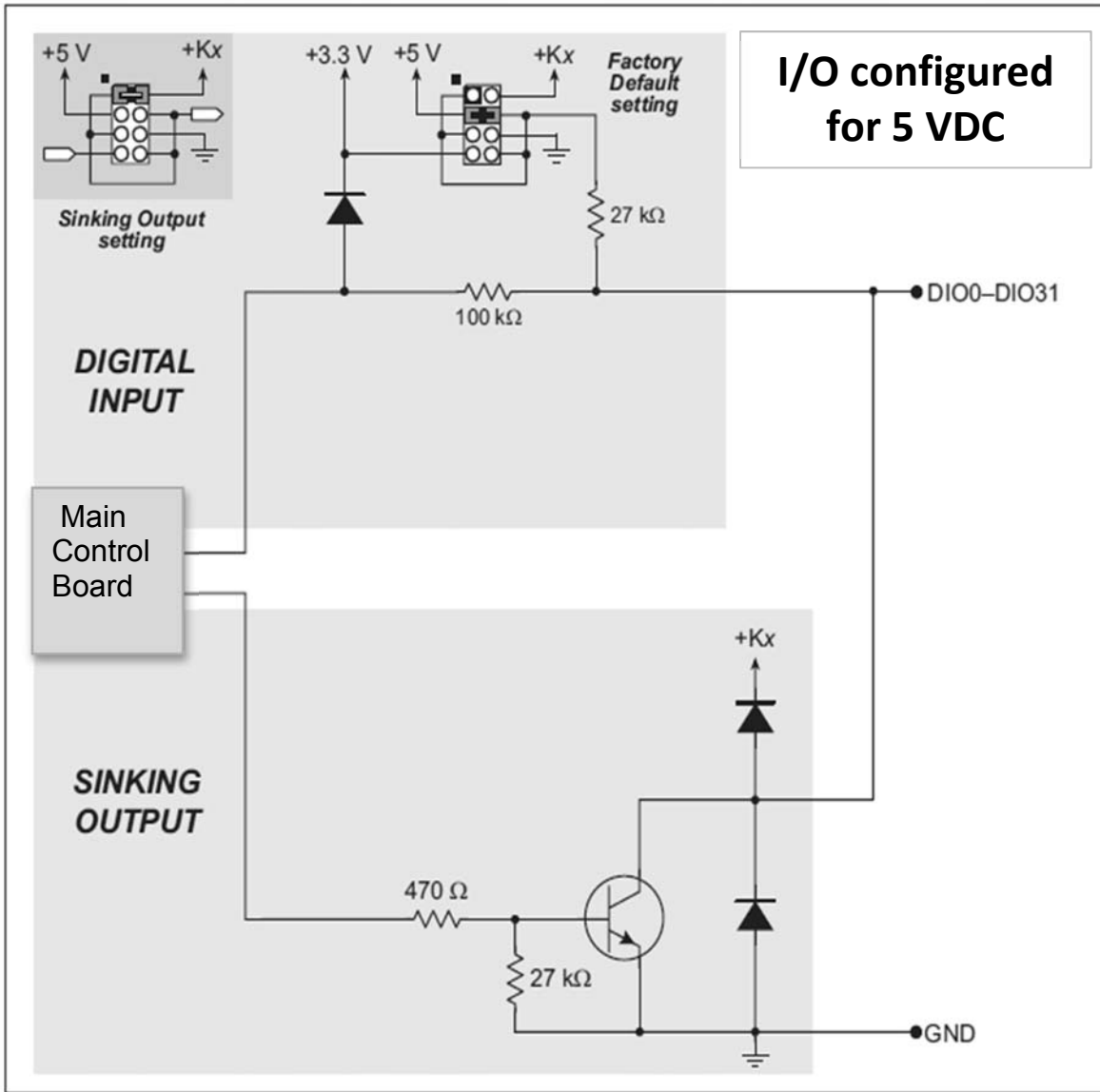

**Schematic 1: Configurable I/O DIO0-DIO31**

---

**Appendix 4-3: Schematic for Buffered A/D Converter Inputs**

---

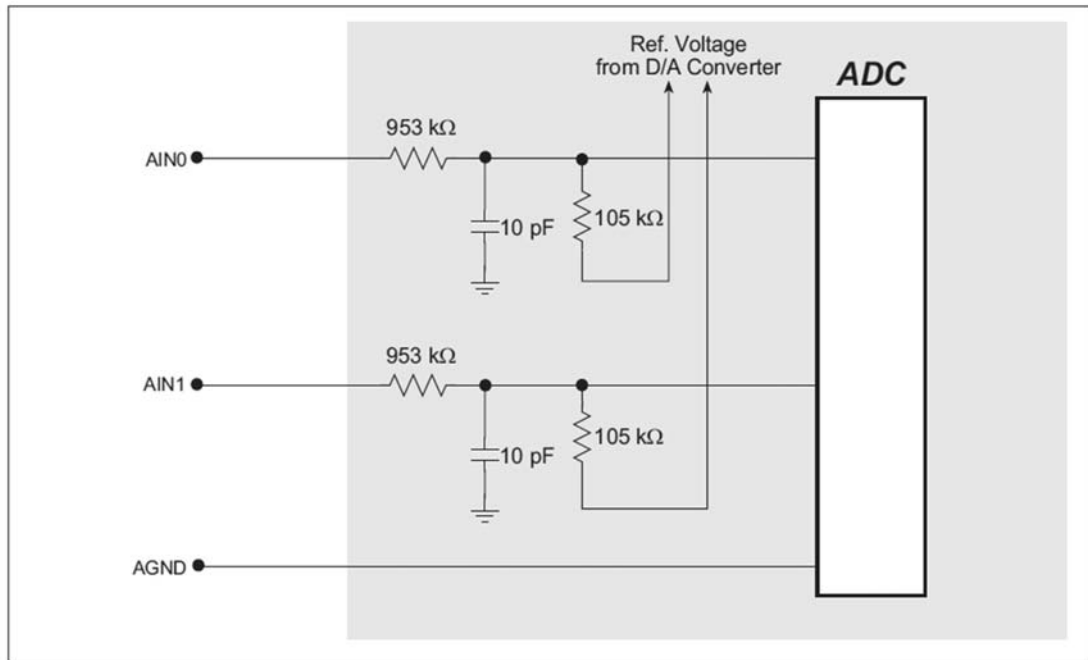

**Schematic 2: Buffered A/D Converter Inputs**

## Appendix 4-4: Schematic for D/A Converter Outputs

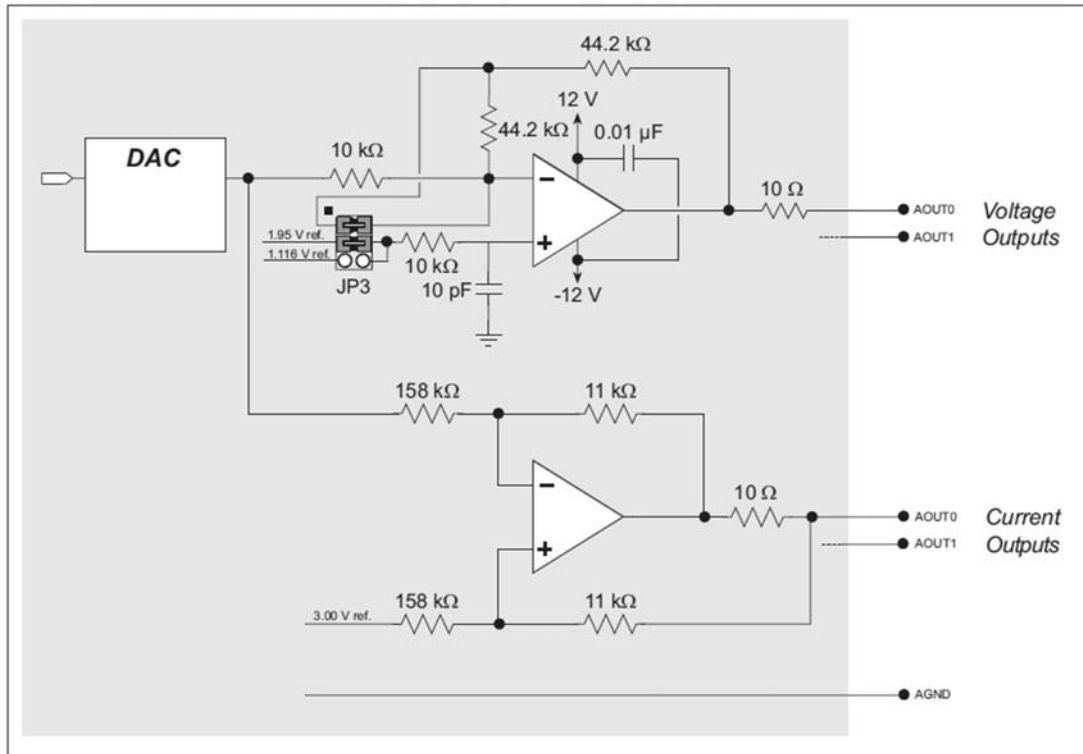

Schematic 3: D/A Converter Outputs



---

**Appendix 4-5: Schematic for Pressure Alarm Input/Output Circuit**

---

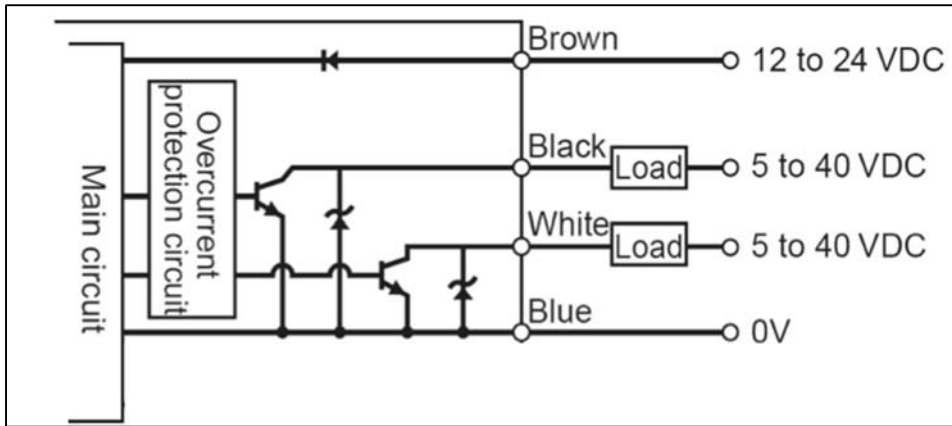

**Schematic 4: Pressure Alarm Input/Output Circuit (AP-C30K/C31K/C33K)**

## Graco Standard Warranty

Graco warrants all equipment referenced in this document which is manufactured by Graco and bearing its name to be free from defects in material and workmanship on the date of sale to the original purchaser for use. With the exception of any special, extended, or limited warranty published by Graco, Graco will, for a period of twelve months from the date of sale, repair or replace any part of the equipment determined by Graco to be defective. This warranty applies only when the equipment is installed, operated and maintained in accordance with Graco's written recommendations.

This warranty does not cover, and Graco shall not be liable for general wear and tear, or any malfunction, damage or wear caused by faulty installation, misapplication, abrasion, corrosion, inadequate or improper maintenance, negligence, accident, tampering, or substitution of non-Graco component parts. Nor shall Graco be liable for malfunction, damage or wear caused by the incompatibility of Graco equipment with structures, accessories, equipment or materials not supplied by Graco, or the improper design, manufacture, installation, operation or maintenance of structures, accessories, equipment or materials not supplied by Graco.

This warranty is conditioned upon the prepaid return of the equipment claimed to be defective to an authorized Graco distributor for verification of the claimed defect. If the claimed defect is verified, Graco will repair or replace free of charge any defective parts. The equipment will be returned to the original purchaser transportation prepaid. If inspection of the equipment does not disclose any defect in material or workmanship, repairs will be made at a reasonable charge, which charges may include the costs of parts, labor, and transportation.

**THIS WARRANTY IS EXCLUSIVE, AND IS IN LIEU OF ANY OTHER WARRANTIES, EXPRESS OR IMPLIED, INCLUDING BUT NOT LIMITED TO WARRANTY OF MERCHANTABILITY OR WARRANTY OF FITNESS FOR A PARTICULAR PURPOSE.**

Graco's sole obligation and buyer's sole remedy for any breach of warranty shall be as set forth above. The buyer agrees that no other remedy (including, but not limited to, incidental or consequential damages for lost profits, lost sales, injury to person or property, or any other incidental or consequential loss) shall be available. Any action for breach of warranty must be brought within two (2) years of the date of sale.

**GRACO MAKES NO WARRANTY, AND DISCLAIMS ALL IMPLIED WARRANTIES OF MERCHANTABILITY AND FITNESS FOR A PARTICULAR PURPOSE, IN CONNECTION WITH ACCESSORIES, EQUIPMENT, MATERIALS OR COMPONENTS SOLD BUT NOT MANUFACTURED BY GRACO.** These items sold, but not manufactured by Graco (such as electric motors, switches, hose, etc.), are subject to the warranty, if any, of their manufacturer. Graco will provide purchaser with reasonable assistance in making any claim for breach of these warranties.

In no event will Graco be liable for indirect, incidental, special or consequential damages resulting from Graco supplying equipment hereunder, or the furnishing, performance, or use of any products or other goods sold hereto, whether due to a breach of contract, breach of warranty, the negligence of Graco, or otherwise.

### **FOR GRACO CANADA CUSTOMERS**

The Parties acknowledge that they have required that the present document, as well as all documents, notices and legal proceedings entered into, given or instituted pursuant hereto or relating directly or indirectly hereto, be drawn up in English. Les parties reconnaissent avoir convenu que la rédaction du présente document sera en Anglais, ainsi que tous documents, avis et procédures judiciaires exécutés, donnés ou intentés, à la suite de ou en rapport, directement ou indirectement, avec les procédures concernées.

---

## Graco Information

---

**For the latest information about Advanjet products, visit [www.advanjet.com](http://www.advanjet.com).**

**For patent information, see [www.graco.com/patents](http://www.graco.com/patents).**

**For customer service and technical assistance, e-mail [info@advanjet.com](mailto:info@advanjet.com)**

**TO PLACE AN ORDER, contact [orders@advanjet.com](mailto:orders@advanjet.com)**

***If calling from the US: 800-333-4877***

***If calling from outside the US: +1-760-294-3392***

*All written and visual data contained in this document reflects the latest product information available at the time of publication.*

*Graco reserves the right to make changes at any time without notice.*

Original instructions. This manual contains English. MM 3A5856

**Graco Headquarters:** Minneapolis

**International Offices:** Belgium, China, Japan, Korea

**GRACO INC. AND SUBSIDIARIES • P.O. BOX 1441 • MINNEAPOLIS MN 55440-1441 • USA**  
**Copyright 2019, Graco Inc. All Graco manufacturing locations are registered to ISO 9001.**

[www.graco.com](http://www.graco.com)  
Revision C, May 2019