

PGMTM

3A5185F

Precision Gear Metering

EN

For metering and dispensing ambient or high-temperature, high-viscosity single-component materials. For professional use only.

Not approved for use in European explosive atmosphere locations.

2500 psi (17.2 MPa, 172 bar) Maximum Working Outlet Pressure
1500 psi (10.3 MPa, 103 bar) Maximum Working Inlet Pressure
See **Technical Specifications** on page 103 for temperature ranges

See page 4 for model information.



Important Safety Instructions

Read all warnings and instructions in this manual. Save these instructions.

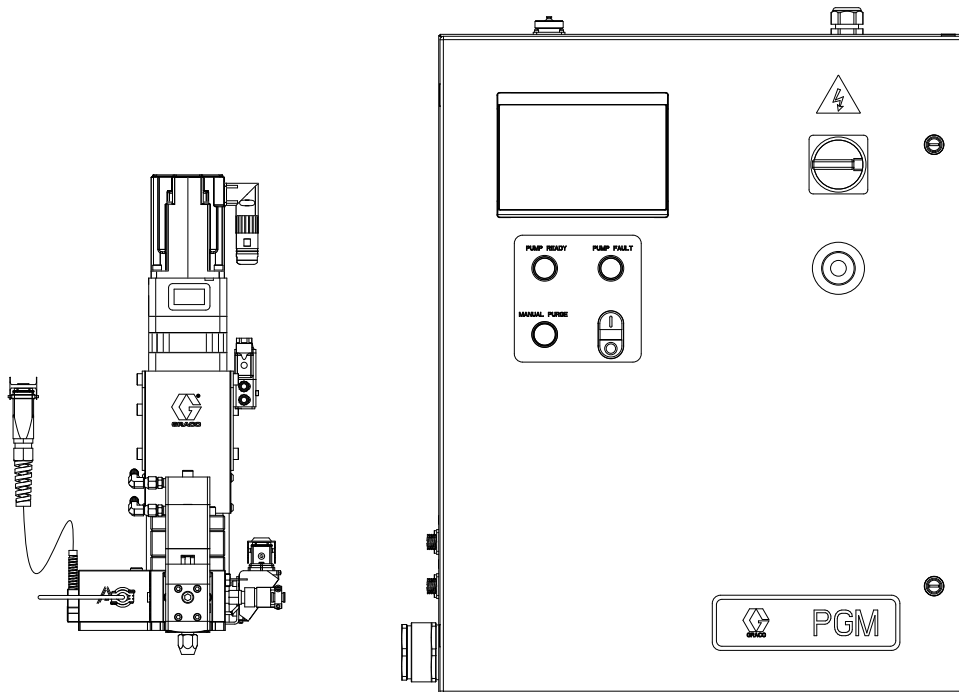

Contents

Related Manuals	3	Maintenance	34
Models	4	Maintenance Schedule	34
Bulk Melt (Therm-O-Flow 20 + Therm-O-Flow 200) and Ambient Hoses	4	Repair	35
Remote Dispense Valves	5	Gear Meter Assembly	35
Fixed Dispense Valves	5	PGM-6 Pump Repair	40
Accessories	5	PGM-20 Pump Repair	44
Warnings	6	Gear Pump Maintenance Guide	47
Overview	8	Installing new heater units and RTD sensors ..	48
System Configurations	8	Parts	49
Component Identification	10	PGM-20 Mounting Frame	49
System Overview	11	PGM-20 Lower Assembly Block	50
Typical Applications	11	PGM-20 Pump Heat Kit	51
Installation	12	PGM Drive - 20 cc Pump	52
Before Installation	12	EnDure Dispense Valve Fix Mounted	53
Overview	12	Gear Meter Assembly Panel	54
Install Control Center	13	PGM Back Panel	56
Install Gear Meter Assembly	14	Remote Mount Amplifiers	57
Install Cable Assemblies	17	PGM Remote Dispense Valve	58
System Setup	18	PGM Ambient Transducer 24E474	59
Overview	18	PGM Ambient Transducer 25E231	59
Configure Control Settings	19	PGM-6 Mounting Frame	60
Configure Mode Settings	19	PGM-6 Drive Kit	61
Configure Delay Settings	20	PGM-6 Lower Assembly Block	62
Adjust Pressure Sensors	20	PGM-6 Pump Heat Kit	63
Configure Errors	21	Schematics	64
Operation	22	Accessory Parts	74
Startup	22	Automation Interface Cable Assembly	74
Load Material	22	Dynamic Regulators (98****)	75
Maintenance Mode Operation	23	EnDure Valve Nozzles	81
Calibration	24	Heater Nests	81
Dispense from Maintenance Screen	25	Appendix A - User Interface Display	82
Automation Control (Normal) Operation	25	Screen Navigation Diagram	82
Typical Automation Cycle	25	Main Screen	83
Pressure Relief Procedure	26	Calibrate Screen	84
Shutdown	28	Home Screen	85
Troubleshooting	29	Maintenance Screen	86
Dispense Valves	30	Robot I/O Screen	87
Errors	31	Setup #1 Screen	88
View Errors	31	Setup #2 Screen	89
Diagnose Errors	31	Setup #3 Screen	90
Clear Errors and Reset Control Unit	31	Setup #4 Screen	91
Error Codes and Troubleshooting	32	Setup #5 Screen	92
		Setup #6 Screen	93
		Supply Pump Screen	94
		Pressure Trend Screen	95

Torque Trend Screen	96
Alarm Screen	97
Appendix B - I/O	98
Using the PGM I/O	98
Appendix C - Theory of Operation	101
Theory of Operation	101
Appendix D - Transducer 25E231 Connection..	102
Technical Specifications	103
Graco Standard Warranty	104
Graco Information	104

Related Manuals

Part	Description
309376	EnDure® Automatic Dispense Valves Instructions-Parts List
310538	Therm-O-Flow® Automatic Dispense Valves Instructions-Parts List
334130	Therm-O-Flow 200 (P/N UH****) Instructions-Parts
311208	Therm-O-Flow 200 (P/N 98****) Instructions
313296	Warm Melt Supply Systems Instructions-Parts
309213	Therm-O-Flow Accessory Heat Zone Controls Instructions-Parts List
313526	Ambient Supply Systems Operation

Models

NOTE: This manual covers a series change to the PGM system. For systems built prior to 2016, refer to manual 3A0260.

Check the identification (ID) plate for the 6-digit part number of the fluid metering system. Use the following matrix to define the construction of the system, based on the six digits. For example, Part **PG0111** represents a PGM fluid metering system (**PG**), with a 6cc system (**0**), unheated (**1**), with controls/3m (**1**), and an EnDure snuff-back (**1**).

NOTE: To order replacement parts, see **Parts** section in this manual. The digits in the matrix do not correspond to the Ref. Nos. in the Parts drawings and lists.

PG	0		1		1		2	
First and Second Digits	Third Digit		Fourth Digit		Fifth Digit		Sixth Digit	
	Size		Heat		Controls *		Valve	
		Description		Description		Description		Description
PG (Precision Gear Meter)	0	6cc	1	Unheated	0	No controls	1	EnDure snuff-back
	2	20cc	2	Heated	1	Controls / 3m	6	Remote mount
					2	Controls / 6m		
					3	Controls / 9m		
					4	Controls / 15m		
					5	No Controls / 104mV transducer		

* PGM Control Center does not include heat controls. Heat loads are configured to be controlled by Therm-O-Flow Controllers.

Bulk Melt (Therm-O-Flow 20 + Therm-O-Flow 200) and Ambient Hoses

Hose Diameter							
		- 8 3/4 in. - 16 JIC	- 10 7/8 in. - 14 JIC	- 12 1-1/16 in. - 12 JIC	- 16 1-5/16 in. - 12 JIC	Non-Heated Hoses	
						3/8 in.	1/2 in.
Hose Length	6 ft	None	19M404 17J654◆	None	19M416 17J666◆	109163	626720 (1/2 in. x 5 ft)
	10 ft	19M402 17J652◆	19M405 17J655◆	19M412 17J662◆	19M417 17J667◆	None	215441
	15 ft	Non	None	None	None	109165/ 685602*	511381*
Fittings							
PGM Inlet (-16 SAE)		None	None	124238 124235 (90°)	124239 124243 † 124236 (90°)	None	None
PGM Outlet (3/4 in. npt)		124286	C20595	15M863	107127	124290 †	124289 †
Valve Inlet		124287	C20768	107052	124288	158256 †	190451 †

* Indicates PTFE hose, all others Buna-N.

◆ Therm-O-Flow part number 98xxxx models.

† Indicates swivel.

Remote Dispense Valves

Part	Description
243694	Heated Dispense Valve
244951	EnDure Valve, Heated, 1/2 in. npt male outlet
244909	EnDure Valve, Heated

Fixed Dispense Valves

Part	Description
244907	EnDure Valve snuff-back









Accessories

Part	Description
24D824	Automation I/O Cable
24E654	Ribbon Nozzle Kit, 10 x 1.5 mm
24E655	Bead Nozzle Kit, 3 mm dia.
25A055	Dynamic Air Regulator for Therm-O-Flow (P/N UH****)
24E575	Dynamic Air Regulator for Therm-O-Flow (P/N 98****)
24E607	Gear Pump Seals, 6 cc
24E619	Gear Pump Seals, 20 cc
24E677	O-ring Kit, 6 cc
24E626	O-ring Kit, 20 cc
24E678	Heated Nest, Pilot
24E679	Heated Nest, Ribbon or Bead
16E242	Nozzle Heater Insert
16E256	Ported Nozzle Heater Insert
25E204	Kit, Key, Coupler, 6 cc
25E205	Kit, Key, Coupler, 20 cc
124267	Seal Housing, 6 cc
24E826	Gear Shaft Repair Kit, 6 cc
24E827	Seal Shaft Repair Kit, 6 cc
124266	Pump Seal Housing, 20 cc
24E824	Gear Shaft Repair Kit, 20 cc
24E825	Seal Shaft Repair Kit, 20 cc
124235	Elbow Fitting, 90 degree, 3/4 in. tube x 16 SAE

Part	Description
124236	Elbow Fitting, 90 degree, 1 in. tube x 16 SAE
124237	Elbow Fitting, 90 degree, 16 SAE x 20 JIC
124238	Adapter Fitting, 3/4 in. Tube x 16 SAE
124239	Adapter Fitting, 1 in. Tube x 16 SAE
124240	Adapter Fitting, 1-1/4 in. Tube x 16 SAE
124241	Adapter Fitting, 16 SAE x 1 in. NPTF
124242	Swivel, 16 SAE x 1 in. NPTF
124243	Swivel, 16 SAE x 1 in. tube
124244	Swivel, 1/2 NPTM x 10 JIC
124245	Swivel, 1/2 NPTM x 1/2 NPTF
124286	Adapter Fitting, 3/4 NPTM x 8 JICM
124287	Adapter Fitting, 1/2 NPTM x 8 JICM
124288	Adapter Fitting, 1/2 NPTM x 16 JICM
124289	Swivel Fitting, 3/4 NPTM x 1/2 NPS
124290	Swivel Fitting, 3/4 NPTM x 3/8 NPS

Warnings

The following warnings are for the setup, use, grounding, maintenance, and repair of this equipment. The exclamation point symbol alerts you to a general warning and the hazard symbols refer to procedure-specific risks. When these symbols appear in the body of this manual or on warning labels, refer back to these Warnings. Product-specific hazard symbols and warnings not covered in this section may appear throughout the body of this manual where applicable.

 <h2 style="margin: 0;">WARNING</h2>	
 	<p>ELECTRIC SHOCK HAZARD</p> <p>This equipment must be grounded. Improper grounding, setup, or usage of the system can cause electric shock.</p> <ul style="list-style-type: none"> • Turn off and disconnect power at main switch before disconnecting any cables and before servicing or installing equipment. • Connect only to grounded power source. • All electrical wiring must be done by a qualified electrician and comply with all local codes and regulations.
    	<p>SKIN INJECTION HAZARD</p> <p>High-pressure fluid from dispensing device, hose leaks, or ruptured components will pierce skin. This may look like just a cut, but it is a serious injury that can result in amputation. Get immediate surgical treatment.</p> <ul style="list-style-type: none"> • Engage trigger lock when not dispensing. • Do not point dispensing device at anyone or at any part of the body. • Do not put your hand over the fluid outlet. • Do not stop or deflect leaks with your hand, body, glove, or rag. • Follow the Pressure Relief Procedure when you stop dispensing and before cleaning, checking, or servicing equipment. • Tighten all fluid connections before operating the equipment. • Check hoses and couplings daily. Replace worn or damaged parts immediately.
	<p>BURN HAZARD</p> <p>Equipment surfaces and fluid that is heated can become very hot during operation. To avoid severe burns:</p> <ul style="list-style-type: none"> • Do not touch hot fluid or equipment.

! WARNING



FIRE AND EXPLOSION HAZARD

Flammable fumes, such as solvent and paint fumes, in **work area** can ignite or explode. Paint or solvent flowing through the equipment can cause static sparking. To help prevent fire and explosion:



- Use equipment only in well-ventilated area.
- Eliminate all ignition sources; such as pilot lights, cigarettes, portable electric lamps, and plastic drop cloths (potential static sparking).



- Ground all equipment in the work area. See **Grounding** instructions.
- Never spray or flush solvent at high pressure.
- Keep work area free of debris, including solvent, rags and gasoline.
- Do not plug or unplug power cords, or turn power or light switches on or off when flammable fumes are present.



- Use only grounded hoses.
- Hold gun firmly to side of grounded pail when triggering into pail. Do not use pail liners unless they are anti-static or conductive.
- **Stop operation immediately** if static sparking occurs or you feel a shock. Do not use equipment until you identify and correct the problem.
- Keep a working fire extinguisher in the work area.



EQUIPMENT MISUSE HAZARD

Misuse can cause death or serious injury.



- Do not operate the unit when fatigued or under the influence of drugs or alcohol.
- Do not exceed the maximum working pressure or temperature rating of the lowest rated system component. See **Technical Specifications** in all equipment manuals.
- Use fluids and solvents that are compatible with equipment wetted parts. See Technical Specifications in all equipment manuals. Read fluid and solvent manufacturer's warnings. For complete information about your material, request Safety Data Sheets (SDSs) from distributor or retailer.
- Do not leave the work area while equipment is energized or under pressure.
- Turn off all equipment and follow the **Pressure Relief Procedure** when equipment is not in use.
- Check equipment daily. Repair or replace worn or damaged parts immediately with genuine manufacturer's replacement parts only.
- Do not alter or modify equipment. Alterations or modifications may void agency approvals and create safety hazards.
- Make sure all equipment is rated and approved for the environment in which you are using it.
- Use equipment only for its intended purpose. Call your distributor for information.
- Route hoses and cables away from traffic areas, sharp edges, moving parts, and hot surfaces.
- Do not kink or over bend hoses or use hoses to pull equipment.
- Keep children and animals away from work area.
- Comply with all applicable safety regulations.



TOXIC FLUID OR FUMES HAZARD

Toxic fluids or fumes can cause serious injury or death if splashed in the eyes or on skin, inhaled, or swallowed.

- Read Safety Data Sheets (SDSs) to know the specific hazards of the fluids you are using.
- Store hazardous fluid in approved containers, and dispose of it according to applicable guidelines.



PERSONAL PROTECTIVE EQUIPMENT

Wear appropriate protective equipment when in the work area to help prevent serious injury, including eye injury, hearing loss, inhalation of toxic fumes, and burns. Protective equipment includes but is not limited to:

- Protective eyewear, and hearing protection.
- Respirators, protective clothing, and gloves as recommended by the fluid and solvent manufacturer.

Overview

System Configurations

Typical Heated System Installation

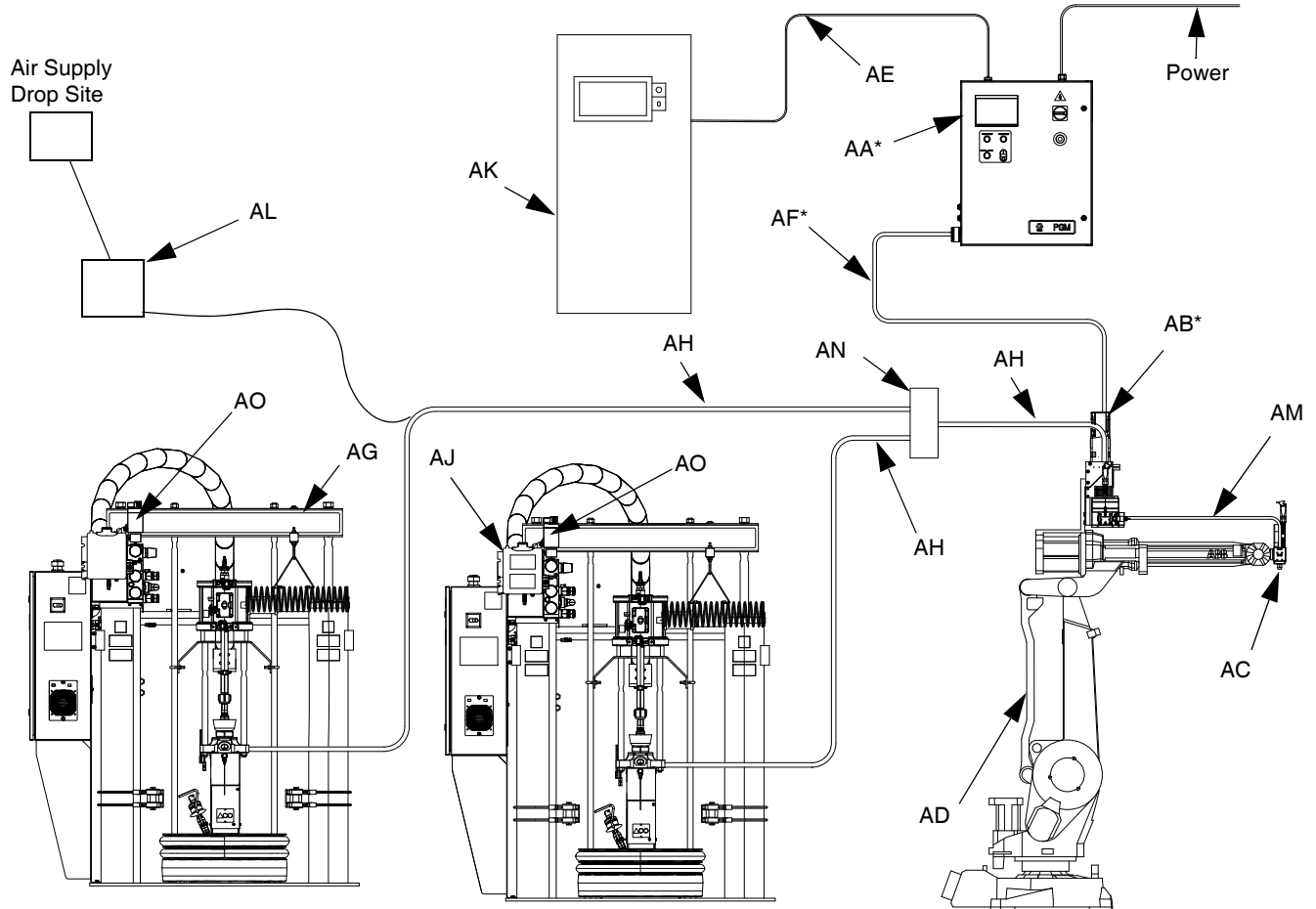

Fig. 1: Typical Heated System Installation

Key:

- AA *Control Center (User Interface)
- AB *Gear Meter Assembly
- AC Applicator/Dispense Valve †
- AD Automation Robot
- AE Automation Interface Cable †
- AF *Gear Meter Cables

- AG Heated Fluid Supply System
- AH Fluid Supply Hose
- AJ Heat Control
- AK Automation Controller
- AL Air Filter Assembly
- AM Remote Dispense Hose †
- AN Heated Manifold
- AO Dynamic Regulator †

- * Included
- † Accessory

Typical Ambient System Installation

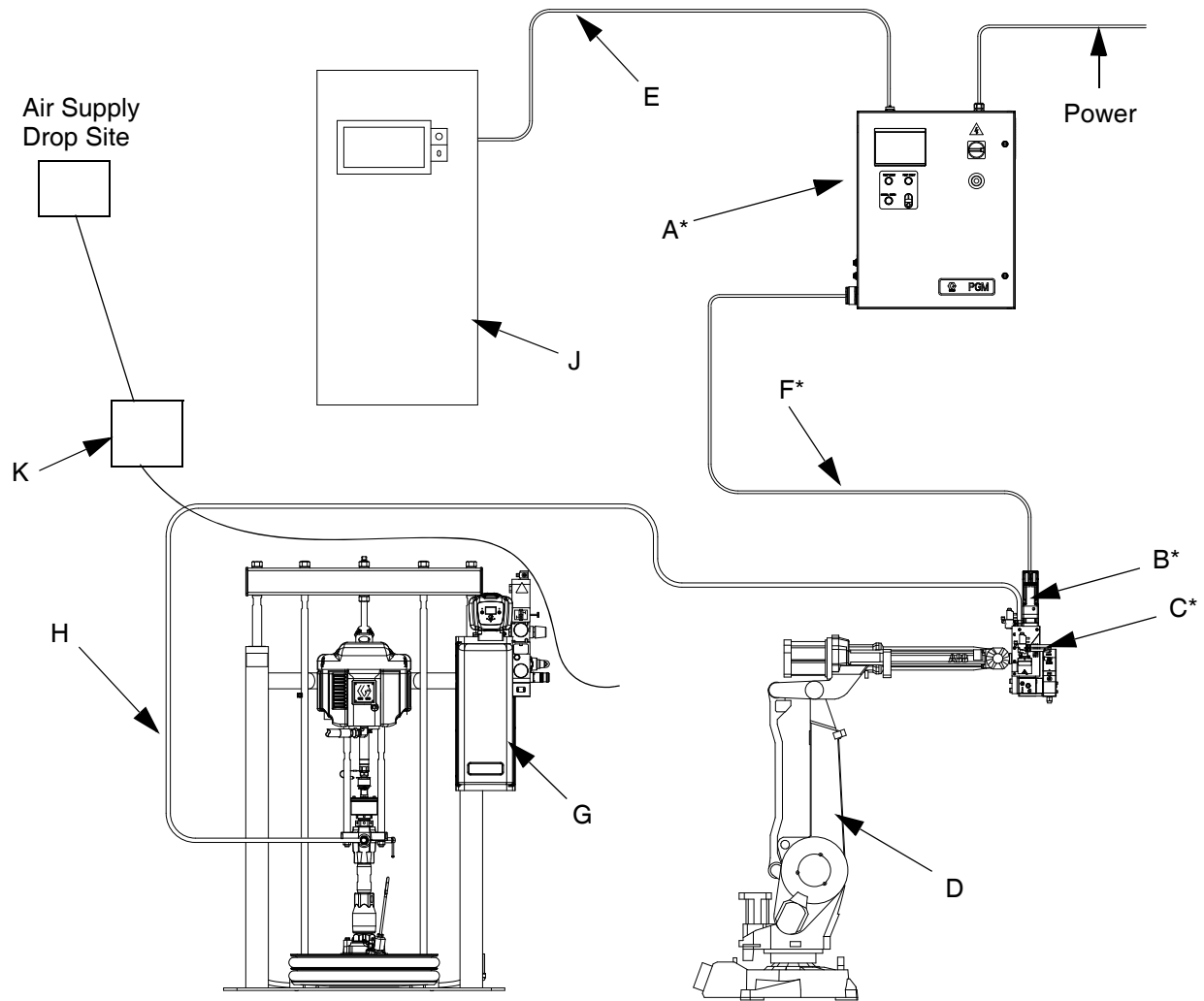

FIG. 2: Typical Ambient System Installation

Key:

- | | | | |
|---|----------------------------------|---|-----------------------|
| A | *Control Center (User Interface) | F | *Gear Meter Cables |
| B | *Gear Meter Assembly | G | Fluid Supply System |
| C | *Applicator/Dispense Valve | H | Fluid Supply Hose |
| D | Automation Robot | J | Automation Controller |
| E | Automation Interface Cable† | K | Air Filter Assembly |

- * Included
 † Accessory

Component Identification

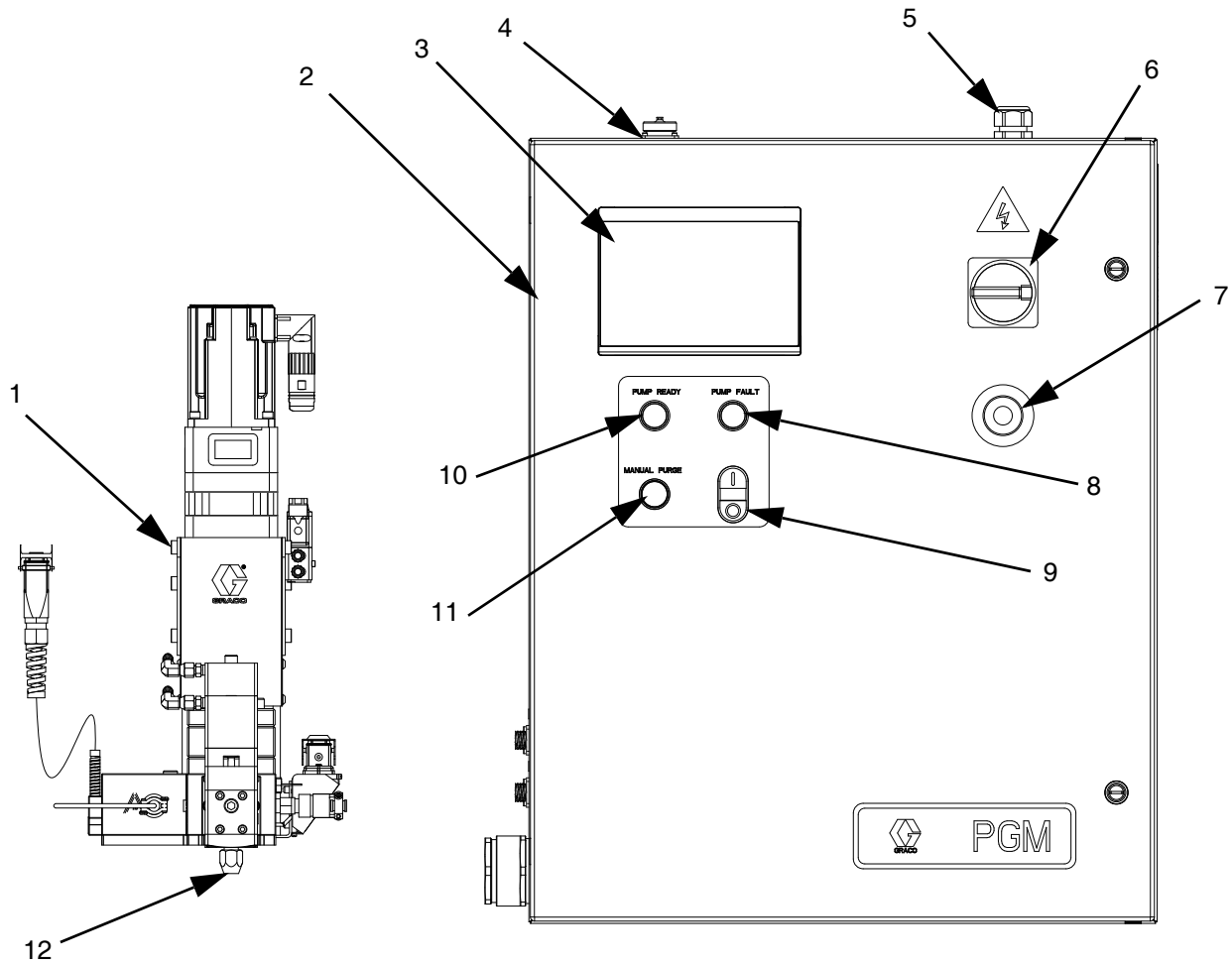

Key:

- | | |
|--|--------------------------------|
| 1 Gear Meter | 7 Emergency Stop |
| 2 System Controls Box | 8 Pump Fault Indicator Light |
| 3 User-Interface Touch Display | 9 Control Power On/Off buttons |
| 4 External Control Interface Connections | 10 Pump Ready Light |
| 5 Power Input | 11 Manual Purge Button |
| 6 Main Power Switch | 12 Dispense Valve |

FIG. 3

System Overview

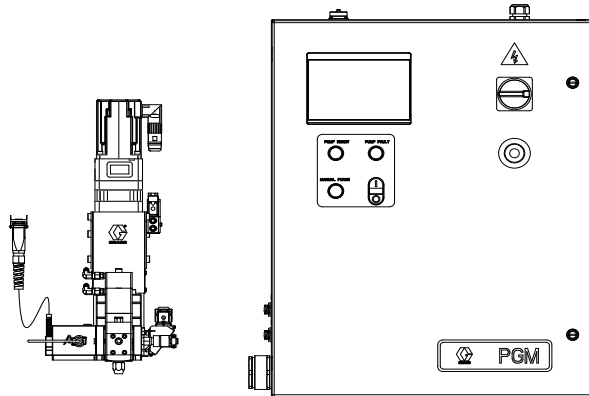

FIG. 4: Control Center Dimensions

The PGM system provides positive displacement metering for precision bead control. The control accepts automation signals to provide accurate and consistent output flow. The gear meter can achieve high flow rates with high viscosity materials.

Control Power On/Off

Control Power is the power for the signals to the gear meter which control gear meter rotation. When Control Power is off, the gear meter cannot rotate.

Pump Ready Light

The Pump Ready light displays when the pump is ready for Automatic Mode dispensing. When Manual mode is enabled, this light will not turn on.

Pump Fault Light

The Pump Fault light is illuminated whenever a pump fault is active.

Manual Purge Button

The Manual Purge button initiates a shot.

Typical Applications

- Solar Panel
 - Perimeter Seal
 - Desiccant
 - Edge Seal
- Automotive Manufacturing
- Window and Door General Assembly

Installation

Before Installation

- Have all system and component documentation available during installation.
- See component manuals for specific data on component requirements. Data presented here applies to the PGM assemblies only.
- Be sure all accessories are adequately sized and pressure-rated to meet system requirements.
- Use the PGM control center only with the PGM metering assembly.

Overview

The basic steps to install a PGM system are shown below. See the separate component manuals for detailed information on supply systems and dispense valves.

NOTICE

To avoid damaging the PGM system, use at least two people to lift, move, or disconnect the system. The system is too heavy for one person to lift or move.

Installation Steps

1. Mount control center.
2. Connect and ground control center.
3. Mount gear meter assembly.
4. Ground gear meter assembly.
5. Check ground continuity.
6. Connect fluid line between gear meter and dispense valve. **For remote mount dispense valves**, connect fluid supply line and air supply to gear meter.
7. Plumb filter assembly near air drop site that will be used for gear meter assembly.
8. Connect other fluid and air lines to additional system components as instructed in their manuals.
9. Install cable assemblies.

Install Control Center

Mount

Ensure the following criteria are met before mounting the PGM control center:

- Select a location for the control center that allows adequate space for installation, service, and use of the equipment.
- For best viewing, the user interface should be 60-64 in. (152-163 cm) from the floor.
- Ensure there is sufficient clearance around the control unit to run cables to other components.
- Ensure there is easy access to an appropriate electrical power source. The National Electric Code requires 3 ft. (0.91 m) of open space in front of the control center.
- Ensure there is easy access to the power switch.
- Ensure the mounting surface can support the weight of the control center and the cables attached to it.

Secure the control center with appropriate size bolts through the 0.50 in. (13 mm) diameter holes. See the mounting dimensions in the following table and FIG. 5.

Control Center Assembly Measurement

A	24.0 in. (610 mm)
B	22.5 in. (572 mm)
C	30.0 in. (762 mm)
D	28.5 in. (724 mm)

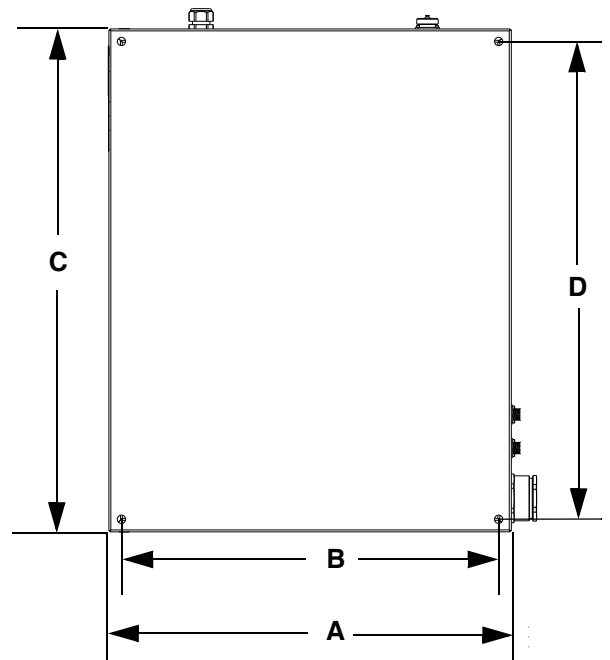

FIG. 5: Control Center Dimensions

Electrical Connections



Follow these precautions when grounding, connecting cables, connecting to a power source or making other electrical connections.

To reduce the risk of fire, explosion, or electric shock:

- The control center must be electrically connected to a true earth ground; the ground in the electrical system may not be sufficient.
- A qualified electrician must complete all grounding and wiring connections.
- For wiring, refer to FIG. 6.

Refer to your local code for the requirements for a “true earth ground” in your area.

NOTICE

If power and grounding connections are not done properly, the equipment will be damaged and the warranty voided.

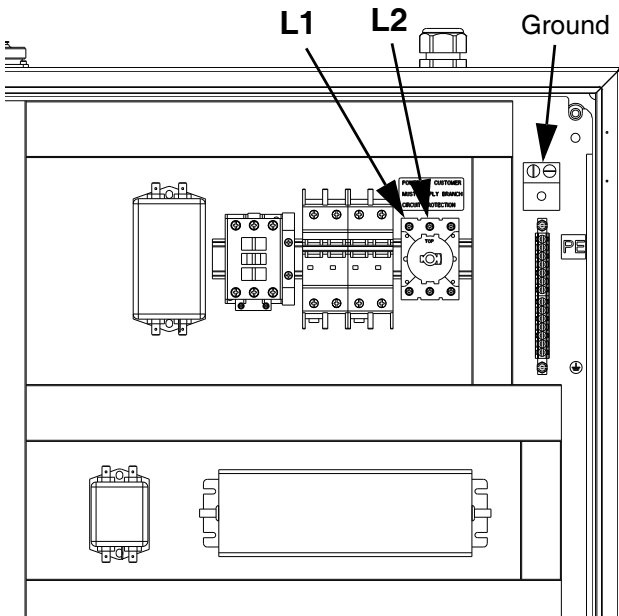

FIG. 6: 240 Vac Wiring

Install Gear Meter Assembly

To install the PGM metering assembly:

- Mount the gear meter assembly.
- Ground gear meter assembly.
- Connect the gear meter assembly to the control center.
- Connect fluid lines and cables.

Mount

Before Mounting Assembly

- See component manuals for specific information on component requirements. Information presented here pertains to the PGM gear meter assembly only.
- Have all system and subassembly documentation available during installation.
- Be sure all accessories are adequately sized and pressure-rated to meet the system's requirements.
- Use only the Graco PGM gear meter assembly with the Graco PGM control center.

Mount Assembly

1. Select a location for the gear meter assembly. Keep the following in mind:
 - Allow sufficient space for installing the equipment.
 - Make sure all fluid lines, cables and hoses easily reach the components to which they will be connected.
 - Make sure the gear meter assembly allows the automation unit to move freely along all axis.
 - Make sure the gear meter assembly provides easy access for servicing its components.

- Mount and secure the gear meter assembly to the automation unit (or other mounting surface) with mounting plate. The mounting plate is tapped with M10 x 1.5 bolts. Maximum bolt length through plate is 0.75 in. (19 mm). See the mounting dimensions in Table 4 and FIG. 7.

Table 4: Gear Meter Assembly Measurement

	6 cc Pump	20 cc Pump
A	2.00 in. (50.8 mm)	3.00 in. (76.2 mm)
B	5.00 in. (127 mm)	3.875 in. (98.43 mm)
C	2.375 in. (60.33 mm)	2.313 in. (58.75 mm)
D	NA	1.063 in. (27.00 mm)

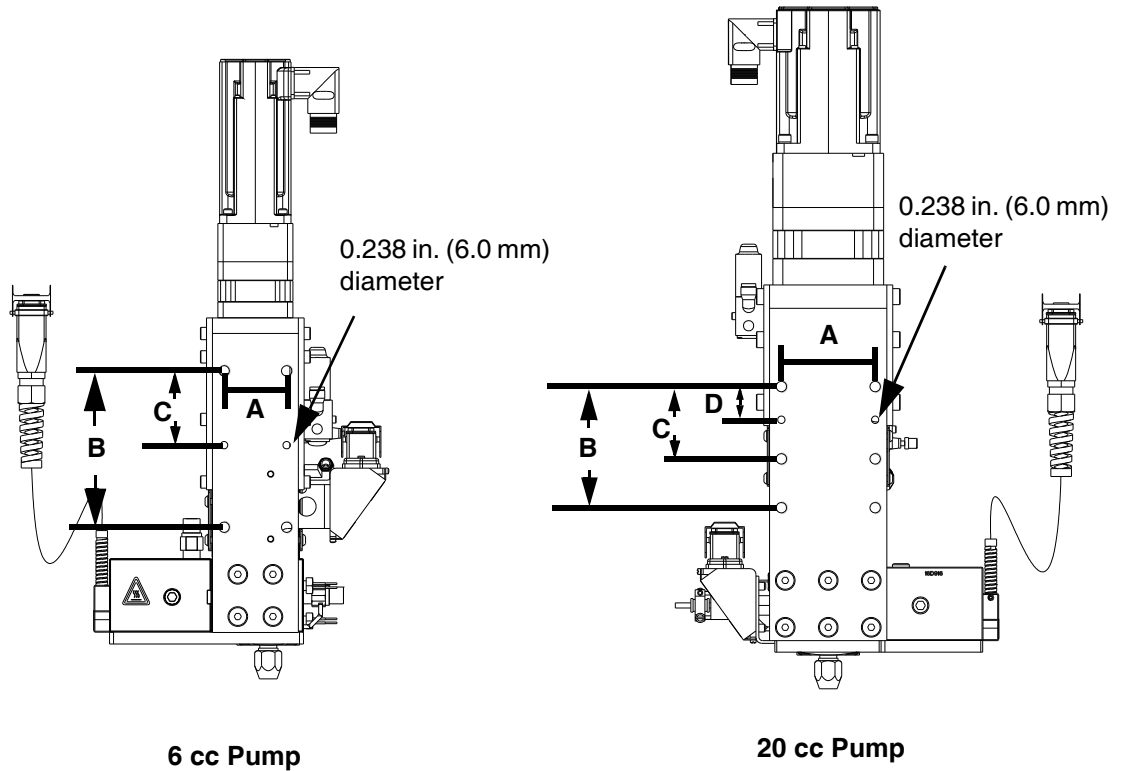





FIG. 7: Gear Meter Assembly Dimensions

Grounding

				
<p>The equipment must be grounded to reduce the risk of static sparking and electric shock. Electric or static sparking can cause fumes to ignite or explode. Improper grounding can cause electric shock. Grounding provides an escape wire for the electric current.</p>				

NOTICE

If power and grounding connections are not done properly, the equipment will be damaged and the warranty voided.

Gear Meter

Ground the gear meter assembly as instructed here and in the individual component manuals. Make sure the gear meter assembly and its components are installed correctly to ensure proper grounding.

Air and Fluid Hoses

For static dissipation, use only electrically conductive hoses or ground the applicator / dispense valves.

Dispense Valve

Follow the grounding instructions in the dispense valve manual.

Connect Fluid and Air Lines

NOTICE

Route all fluid and air lines carefully. Avoid pinching and premature wear due to excessive flexing or rubbing. Hose life is directly related to how well they are supported.

Follow the instructions in your separate component manuals to connect air and fluid lines. The following are only general guidelines.

- The PGM gear meter assembly should be installed on the automation unit or in another appropriate place, as close as practical to the dispense valve.

- **For a remote mount dispense valve**, connect a fluid line between the gear meter outlet and the dispense valve. Shorter fluid lines (hoses) will provide better fluid system response.
- See page 4 for list of inlet fittings.

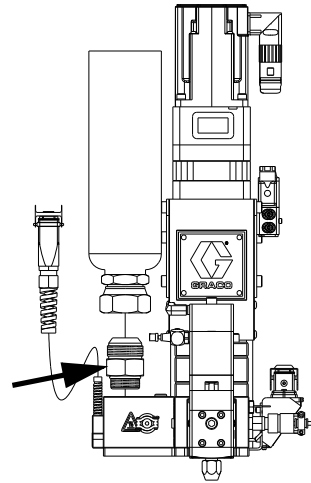

FIG. 8: Inlet Fitting

- Air must be clean and dry, between 60-100 psi (0.41-0.68 MPa, 4.14-6.89 bar). Flush air line before plumbing in air filter assembly (234967). Plumb in air filter assembly near air drop site (upstream of PGM). Adding an air regulator to this line will provide more consistent dispense valve response times.
- Connect a 1/4 in. OD air supply line to the inlet port on the PGM air supply inlet.

NOTE: To maximize system performance keep the dispense hose length as short as the application will allow.

Install Cable Assemblies

1. Connect servo motor power and feedback cables.
2. Connect pressure transducer cable.
3. Connect dispense valve solenoid cable.
4. Connect heat cables, if equipped, to Therm-O-Flow controller.

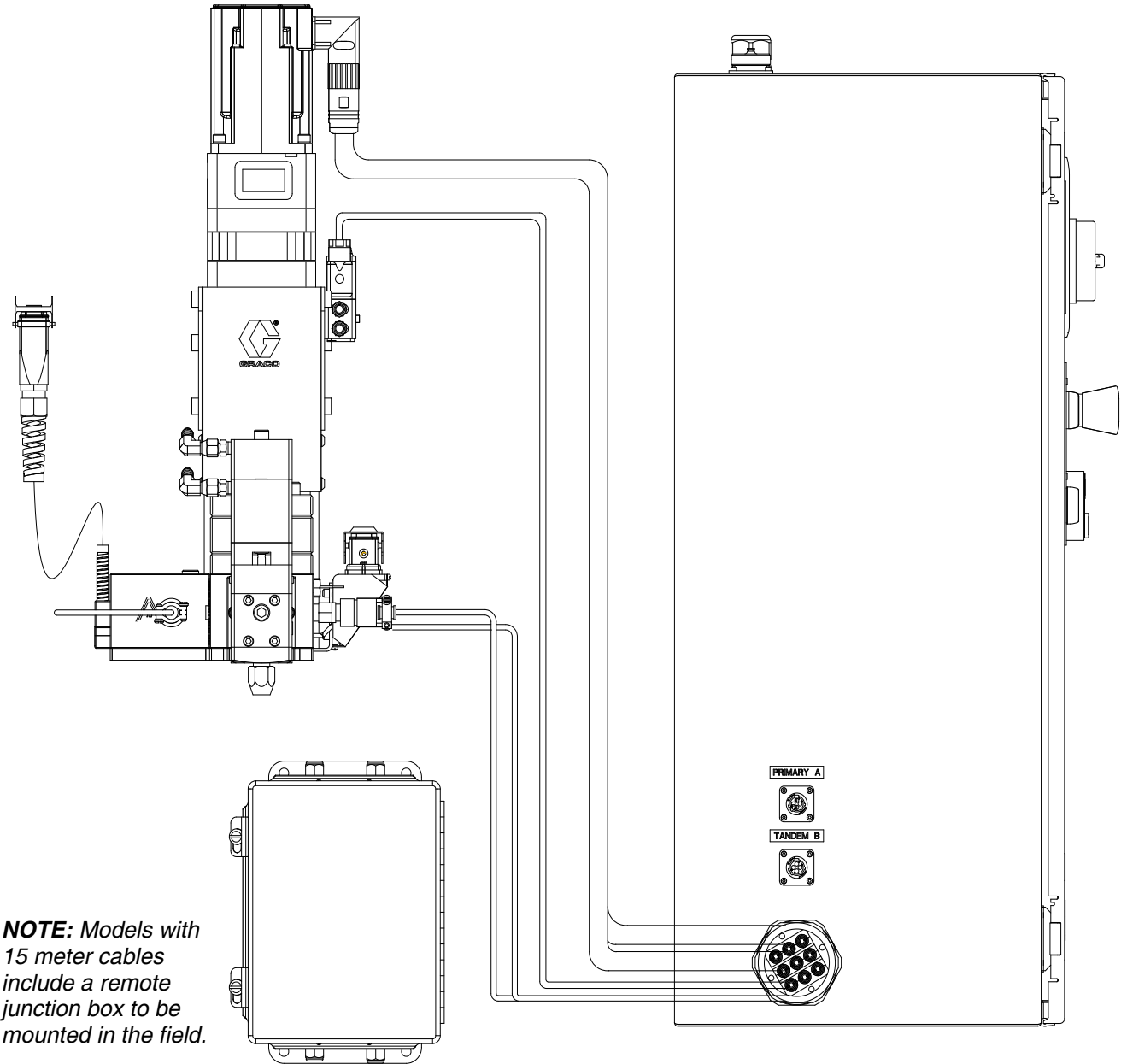

NOTE: Models with 15 meter cables include a remote junction box to be mounted in the field.

FIG. 9: Cable Installation Diagram

System Setup

Overview

The PGM system compensates for temperature, flow, or pressure fluctuations. However, if there is a hardware change on the supply system or the dispense material is changed, the PGM system must be setup again.

After material is loaded into the supply system, set up the PGM system using the Setup screens. FIG. 10 shows the major system setup steps. The following subsections provide instructions to complete each setup step. Once these steps are complete the module is ready for operation.

NOTE: See Appendix A - User Interface Display on page 82 for detailed operating instructions for each user interface screen.

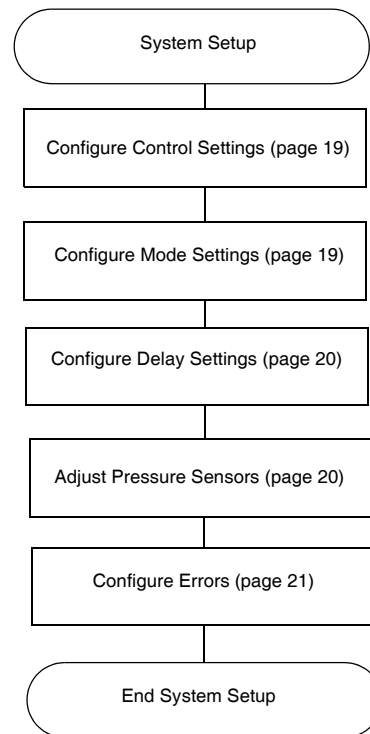

FIG. 10

Configure Control Settings

Set the controls for the dispense source, how dispense commands are sent, and auto mode settings.

- From the Home screen, select the Setup icon



NOTE: The Setup screens are password protected. Enter password “PGM17” to access the following screens.

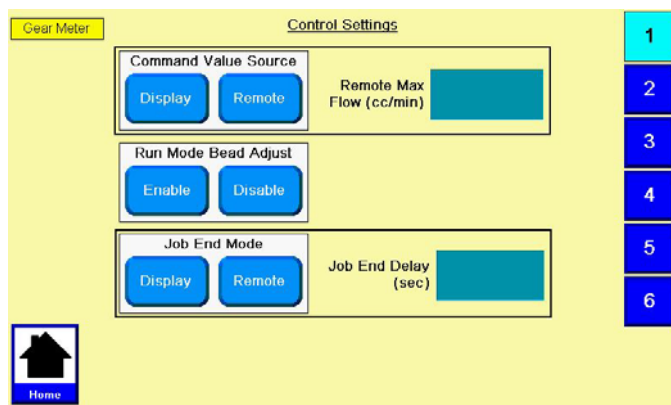

FIG. 11

- Select Display or Remote from the Command Value Source Options.
- If Command Value Source is set to Remote,** enter the Remote Max Flow (cc/min) for the 10 VDC command source.
- Select Enable or Disable for Run Mode Bead Adjust Options. Default is Disable.
- Select Display or Remote for Job End Mode Options.
- If Job End Mode is set to Display,** press Job End Delay Display field and enter desired delay time in seconds.

Configure Mode Settings

Set the dispense mode (bead or shot). The bead scale and pre-charge are also adjustable from the Mode Settings screen.

NOTE: See Appendix A - User Interface Display on page 82 for a description of each feature.

- With the system in setup mode, press **2** to navigate to the Mode Settings screen.

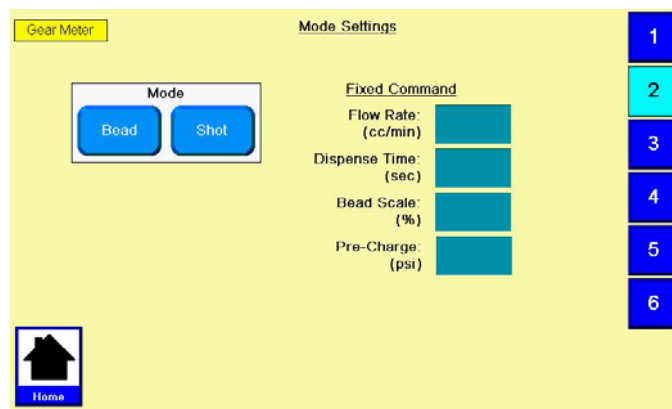

FIG. 12

- Select Bead or Shot for the Dispense Mode.
- If Command Value Source is set to Display,** enter the flow rate in cc/min in the Fixed Command Flow Rate. See **Configure Control Settings** for instructions to set the Command Value Source value.
- If Shot Time is displayed, enter the Shot Time in Seconds.

NOTE: Shot Time is only displayed if Dispense Mode is set to Shot.

Configure Delay Settings

Set on and off delays (in milliseconds) for the dispense valve.

1. With the system in setup mode, press **3** to navigate to the Delay Settings screen.

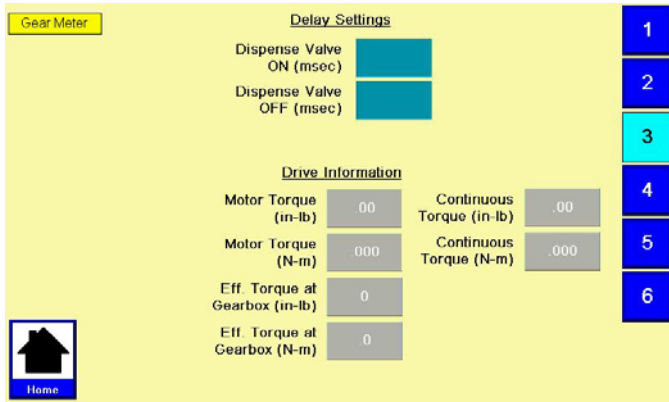

FIG. 13

2. Press the On Delay field and enter a desired delay value in milliseconds. Default is zero milliseconds.
3. Press the Off Delay field and enter a desired value in milliseconds. Default is zero milliseconds.

Adjust Pressure Sensors

Set pressure offsets and pressure limits.

1. With the system in setup mode, press **5** to navigate to the Pressure Sensor screen.

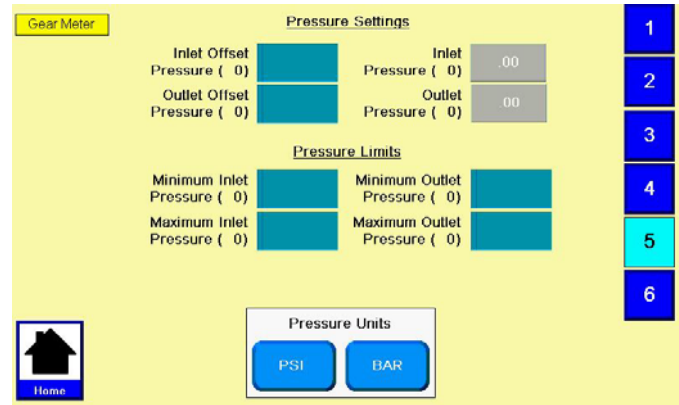

FIG. 14

2. Set the desired offset for the inlet and outlet pressures. Remove all pressure on the sensors, and then adjust the offset so the measured value reads 0.

NOTE: Offsets are set at the factory.

3. Set the desired minimum and maximum pressure limits for the inlet and outlet.

NOTE: These values may need changed after the system has gone through the Startup procedure.

Configure Errors

Set the error type (error or deviation) that will be issued if the pressure or drive torque goes outside the set high and/or low limits. See **Appendix A - User Interface Display** on page 82 for information on the purpose of each error type.

NOTE: When an alarm is set to Error the machine will be disabled when the alarm occurs.

1. With the system in setup mode, press **6** to navigate to the Errors screen.

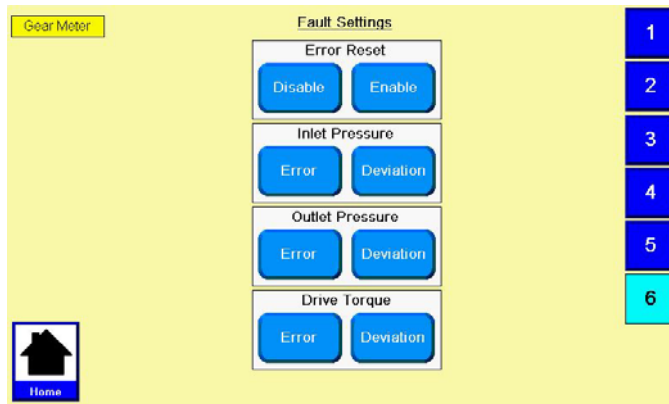

FIG. 15

2. Select Enable or Disable for the Error Reset.
3. Select Error or Deviation for the Inlet Pressure.
4. Select Error or Deviation for the Outlet Pressure.
5. Select Error or Deviation for the Drive Torque.

Operation

Startup



Initial Startup

1. Ensure the PGM control enclosure and all of the proper connections to and from the control enclosure have been made. Ensure fittings are tight.
2. Read and understand the **Operation** and **User Interface** sections of this manual along with the related manuals.
3. Continue startup with Step 2 in **Standard Startup**.

Standard Startup

1. Carefully inspect the entire system for signs of leakage or wear. Replace or repair any worn or leaking components before operating the system.
2. Press the Stop button on the control enclosure.
3. Turn on air and electrical power to the system.
4. Turn on the main power to supply power to the PGM.
5. **Check Interface Signals:** If this is a new installation, power on each system input and verify that each input is being received. See **Appendix B - I/O** on page 98.
6. For heated systems, open the dispense valve over a waste container while the system is heating up. This will prevent a pressure build-up caused by fluids or gases expanding from the heat.
7. Turn on the material supply system.

Load Material

Before using the system, material must be loaded into the supply system.

1. If this is a new installation, follow the **Initial Startup** procedure. Otherwise, follow the **Standard Startup** procedure.
2. Turn on the fluid supply pressure to the fluid inlet block for the PGM.
3. Place the dispense valve over a waste container.
4. Navigate to the Maintenance screen. See **Screen Navigation Diagram** on page 82 in the **Appendix A - User Interface Display** section.

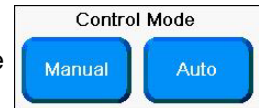

5. Select Manual Control Mode
6. Enter the minimum flow rate to prime the system. See the following table.

Pump Size cc / revolution	Min Flow Rate cc / minute
6	12
20	40

7. Press and hold the manual start button . Dispense fluid until clean, air-free fluid flows from the dispense valve.

NOTE: The manual purge button on the user-interface panel can be used to prime the system.

8. If desired, press  to navigate to the Home screen.

Maintenance Mode Operation

Operating from maintenance mode enables the pump to

begin dispensing when the user presses



Dispense parameters and duration depend on the selected control.

Verify System Operation

Use maintenance mode to manually check the operation of the PGM system components before switching over to automation control (normal operation).

NOTE: Perform any of the following procedures while in maintenance mode.

Set Inlet Pressure

The inlet pressure reading should be in the range of 300 psi (2.1 MPa, 21 bar) to 1500 psi (10.3 MPa, 103 bar). The recommended inlet pressure should be 500 psi (3.4 MPa, 34 bar) lower than the outlet pressure.

Follow steps in the supply system manual to set the inlet pressure.

NOTICE

Excessive inlet pressure will cause accelerated wear on the gear meter seals and the pump feed system.

Feed System Pressure Drop

During material flow, the PGM inlet pressure decreases. The amount the pressure decreases is the amount of pressure lost between the feed pump and the PGM inlet.

With high viscosity fluids, long line lengths, or small diameter line sizes this pressure decrease can be thousands of psi (hundreds of bar). This means that the static pump pressure is set much higher than the PGM needs at its inlet. To prevent excessive static pressure at the inlet of the PGM, a dynamic regulator is recommended on air motor supply air. During dispense the normal pump regulator is active. During a stalled condition the dynamic regulator is active.

Dispense Weight Verification

1. From maintenance screen, select Shot mode.
2. Enter a 10 second shot time.
3. Enter the desired flow rate.
4. Record a minimum of 5 shot weights.
5. If shot weights are inconsistent check feed pressure or reduce flow rate and repeat shot test.

NOTE: Regular weight checks are recommended to ensure system is performing properly.

Calibration



1. Perform **Startup** procedure, page 22. Verify all system components are at desired pressures and temperatures. Adjust as desired.
2. Navigate to the Calibrate screen. See **Screen Navigation Diagram** on page 82 in the **Appendix A - User Interface Display** section.

NOTE: PGM systems are calibrated at the factory. Perform calibration after pump maintenance or during troubleshooting (see page 29 for troubleshooting matrix).

3. Press the Enable Calibration button .

4. Weigh one disposable container and tare the scale.
5. Place container below dispense tip.
6. Press the Start Low Speed Calibration

button .

7. Weigh the container.
8. Divide the weight of the dispensed material by the specific gravity to determine the volume.
9. Enter the volume into the Low Speed Calibration

Actual Volume input box .

10. Weigh a second disposable container and tare the scale.
11. Place container below dispense nozzle.
12. Press the Start High Speed Calibration

button .

13. Weigh the container.
14. Divide the weight of the dispensed material by the specific gravity to determine the volume.

15. Enter the volume into the High Speed Calibration

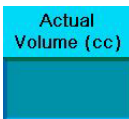
Actual Volume input box .

16. Press the Done button .

17. If desired, press  to navigate to the Main screen.

Dispense from Maintenance Screen

1. Navigate to the Maintenance screen. See **Screen Navigation Diagram** on page 82 in the **Appendix A - User Interface Display** section.

2. Select Manual Control Mode

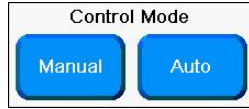

3. Select Bead or Shot from the Manual Mode Option.

Manually Dispense Fluid

1. Press  and verify the dispense valve opens.

2. Continue to press  as long as needed to load or dispense material. Release to stop dispensing.

3. If desired, press  to navigate to the Home screen.

Automation Control (Normal) Operation

During automation control (normal operation) the PGM automatically dispenses when it receives a command from the automation unit.

NOTE: See Appendix B - I/O on page 98.

To enter Auto mode, select Auto (A) Control

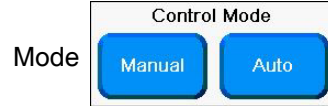

Typical Automation Cycle

In order for the system to run it must be in Auto mode. Before a cycle begins the robot outputs should have the following values:

- Job Complete: 0
- Dispense Trigger: 0

A typical cycle consists of the following dispensing sequence.

1. The robot checks that Dispenser Ready signal is set to On (High). If On, a cycle can begin.
2. If command source is set to Remote, robot sends 0-10 VDC Flow Rate signal.

NOTE: See Setup Screen 1 information in the Appendix A - User Interface Display section beginning on page 82.

3. Robot turns on dispense trigger.
4. PGM turns on In Cycle.
5. Robot removes dispense trigger.
6. If Job Complete is set to Remote, robot turns on Job Complete.
7. Robot removes Job Complete before starting the next cycle.

NOTE: In the event of a deviation alarm, the Dispense Ready signal will remain on along with the alarm signal. In the event of an error alarm, the Dispense Ready signal will turn off and the alarm signal will remain on.

Pressure Relief Procedure



Follow the Pressure Relief Procedure whenever you see this symbol.



This equipment stays pressurized until pressure is manually relieved. To help prevent serious injury from pressurized fluid, such as skin injection, follow the **Pressure Relief Procedure** when you stop dispensing and before cleaning, checking, or servicing the equipment.

1. Shut off the fluid supply to the PGM inlet block.
2. If equipped, place a waste container beneath the fluid drain valve under the filter.
3. Place a waste container beneath the dispense valve.
4. Slowly open the drain valve at each fluid filter to relieve fluid pressure. Close valve when pressure gauge reads zero.
5. Navigate to the Maintenance screen. See **Screen Navigation Diagram** on page 82 in the **Appendix A - User Interface Display** section.

6. Perform the following steps to perform a low flow dispense:
 - a. From the Mode drop-down menu, select Bead mode.
 - b. Enter the minimum flow rate for your system. For example, 12 cc/min or 40 cc/min depending on the size of the gear meter.
 - c. Press  or the Purge button on the control enclosure to begin the low flow dispense.
 - d. Continue to dispense until the inlet pressure on the PGM is near zero.
 - e. Visually locate the plug installed at the back of the inlet block.
 - f. Place a container under the plug and slowly remove the plug to relieve remaining inlet pressure.
7. In maintenance mode, select Open Dispense Valve

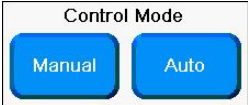
Control mode , which opens the dispense valve. Press the manual dispense but-

ton  until fluid flow stops.

8. If the dispense device cannot be actuated from the control center, refer to FIG. 16 and perform the following steps to open the dispense valve and relieve fluid pressure:
 - a. Manually actuate the plunger on the solenoid, that opens the dispense valve to relieve fluid pressure. Refer to FIG. 16.
 - b. Continue actuating the plunger until all pressure is purged from the system between the needle and dispense valve before proceeding to the next step.
9. If you suspect that a valve, hose, or dispense nozzle is clogged or that pressure has not been fully relieved:
 - a. Very slowly remove the dispense tip, clean the orifice, and continue relieving pressure as described in steps 6-8.
 - b. If this does not remove the obstruction, very slowly loosen the hose end coupling to relieve pressure gradually, then loosen the coupling completely. Clear the valves or hose. Do not pressurize the system until the blockage is cleared.
10. Shut off power and air to the fluid supply system.

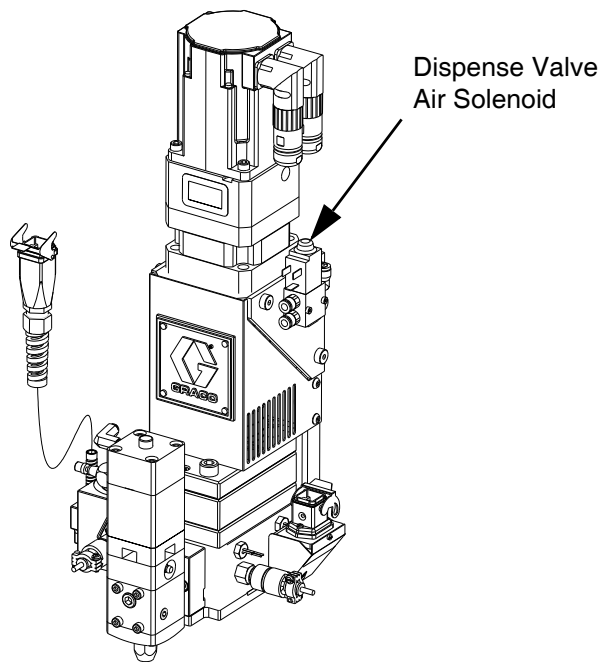

FIG. 16: Dispense Valve Air Solenoid

Shutdown



1. Press the Stop button. See FIG. 17.
2. Shut off the material supply to the gear meter/meter.
3. Shut off heat to PGM. See related manuals section for Therm-O-Flow manual and Accessory Heat Control.
4. For heated systems, open the dispense valve over a waste container while the system is cooling down. This will prevent a pressure build-up caused by fluids or gases expanding from the heat.
5. Shut off power and air to the fluid supply system.
6. Turn off the main power supply.

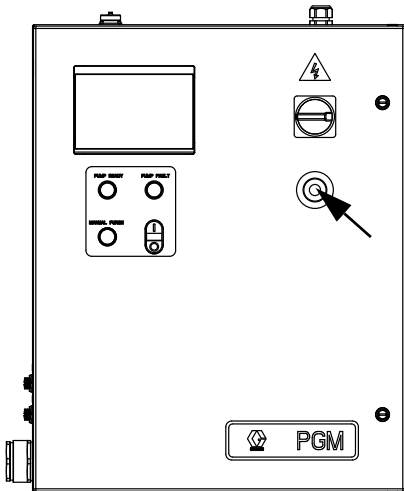
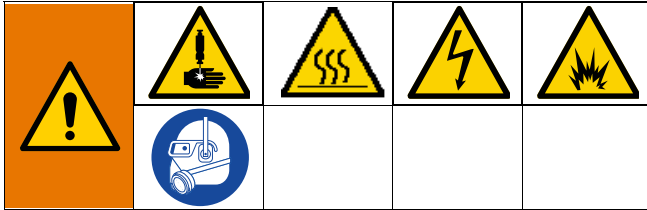

FIG. 17: Stop Button

Troubleshooting



NOTE: Check all possible solutions in the chart below before you disassemble the system.

Refer to Supply Systems manual for additional troubleshooting; refer to **Related Manuals** on page 3. Also refer to **Error Codes and Troubleshooting**, page 32.

PGM Fluid Assembly

Problem	Cause	Solution
No Inlet Pressure	No air pressure on supply system	Verify supply system pressure
	Leak in supply system	Check supply lines and connections
	False signal being sent to control	Check inlet pressure sensor output; verify that it corresponds to zero pressure; replace sensor and/or amplifier
	Leak at PGM drive shaft	Replace drive shaft seals
No Outlet Pressure	Dispense motor not rotating	Refer to Error code section of the manual; Cycle power and perform startup
	Dispense Off delay set too long	Verify Dispense valve delays in setup screens
	Dispense valve solenoid stuck open	Verify function of dispense valve
	False signal being sent to control	Check outlet pressure sensor output; verify that it corresponds to zero pressure; replace sensor and/or amplifier
High Outlet Pressure	Blocked dispense tip	Replace dispense tip
	Flow rate too high for application	decrease flow rate
	Dispense valve On delay set too long	Verify Dispense valve delays in setup screens
	Dispense valve solenoid stuck closed	Verify function of dispense valve

Dispense pattern too light	Supply pressure too low	Verify inlet pressure needed for flow rate
	Flow rate too high for application	Perform dispense weight verification, see Calibration procedure on page 24; Lower flow rate and repeat
Measured flow does not match command	Supply pressure too low	Verify inlet pressure needed for flow rate
	Flow rate too high for application	Perform dispense weight verification, see Calibration procedure on page 24; Lower flow rate and repeat
	Gear meter is not calibrated	Perform calibration; Perform weight verification, see Calibration procedure on page 24
	Gear meter is worn or damaged	Perform weight verification, see Calibration procedure on page 24; if weights are not repeatable repair or replace gear meter

Dispense Valves

Problem	Cause	Solution
Valve not opening	Air not getting to open port	Verify air pressure solenoid
	No Dispense Trigger signal from automation unit	Check input from automation unit
Valve not shutting off	Air not getting to close port (except AutoPlus valve)	Verify air pressure to solenoid
		Verify solenoid operation
	Verify air line routing and connections	
	Dispense Trigger signal from automation unit is on	Check input from automation unit
Sluggish open/close	Air pressure low	Verify air pressure is above 60 psi (0.4 MPa, 4 bar)
	Needle/seat worn	Rebuild valve; replace needle/seat
	Pressurized material past the valve shut-off is escaping	Reduce running pressure
		Reduce nozzle length
	Increase nozzle orifice size	
Material leaks from back of valve	Shaft seal is worn	Rebuild valve; replace seals
Air leaks from dispense valve	Loose air connections	Check air connections; tighten if necessary
	Worn piston o-ring	Rebuild valve; replace piston o-ring

Error Codes and Troubleshooting

Error No.	Error Name	Error Description	Error Type	Cause	Solution
PGM Control Errors					
1	Control Power Off	Control power has been removed	Advisory	Stop button or E-stop	Press Control Power button
2	Inlet Pressure Deviation	Inlet material pressure outside limits	Deviation	Feed pressure set too high or too low. Limits are not set correctly	Verify pressure limits in Setup Screen 5. Verify supply pressures during dispense.
3	Inlet High Pressure Error	Inlet material pressure above max limit	Alarm	Feed pressure too high. Limits are not set correctly.	Verify pressure limits in Setup Screen 5. Verify supply pressures during dispense.
4	Inlet Low Pressure Error	Inlet material pressure below min limit	Alarm	Feed pressure too low. Limits are not set correctly.	Verify pressure limits in Setup Screen 5. Verify supply pressures during dispense.
5	Outlet Pressure Deviation	Outlet material pressure outside limits	Deviation	Back pressure is too high or too low. Limits are not set correctly.	Verify pressure limits in Setup Screen 5. Verify outlet pressures during dispense.
6	Outlet High Pressure Error	Outlet material pressure above max limit	Alarm	Back pressure is too high. Limits are not set correctly.	Verify pressure limits in Setup Screen 5. Verify outlet pressures during dispense.
7	Outlet Low Pressure Error	Outlet material pressure below min limit	Alarm	Outlet pressure too low. Limits are not set correctly.	Verify pressure limits in Setup Screen 5. Verify outlet pressures during dispense.
8	Inlet Max Pressure Fault - Relieve Pressure and Cycle Power	Inlet material pressure exceeds max rated pressure	Alarm	Feed system pressure is set too high. Pressure sensor damaged.	Perform pressure relief procedure. Change inlet supply pressure. Cycle power; Verify Pressure sensor is working properly.

Error No.	Error Name	Error Description	Error Type	Cause	Solution
9	Outlet Max Pressure Fault - Relieve Pressure and Cycle Power	Outlet material pressure exceeds max rated pressure	Alarm	Dispense valve not opening. Flow rate too high. Material not at temperature.	Perform pressure relief procedure; Cycle Power; Verify Dispense valve function; Perform weight check verification; Reduce flow rate.
10	Drive Torque Deviation	Motor exceeds continuous rated torque	Deviation	Flow rate too high. Dispense Valve not opening. Material not at temperature.	Lower flow rate; reduce outlet pressure drop; Verify material temperature.
11	Drive Torque Error	Motor exceeds continuous rated torque	Alarm	Flow rate too high. Dispense Valve not opening. Material not at temperature.	Lower flow rate; reduce outlet pressure drop; Verify material temperature.
12	Drive Peak Torque Error - Drive disabled, Cycle Power	Motor exceeds peak torque rating	Alarm	Flow rate too high. Dispense Valve not opening. Material not at temperature.	Cycle Power Lower flow rate; reduce outlet pressure drop; Verify material temperature.
13	Pre-Charge Timeout	Pre-Charge Pressure was not reached after dispense	Advisory	Pre-Charge value not set correctly.	Set Pre-Charge to zero. Monitor outlet pressure; Adjust Pre-Charge pressure.
14	High Pressure Interlock OFF	Pressure limit is bypassed	Advisory	Pressure sensors are disabled.	Contact Graco customer service.
15	Dispense Valve Open (Auto Default)	Dispense valve is open	Advisory	Dispense valve open button has been selected.	From the Maintenance screen select Dispense valve Auto.
16	Calibration is enabled complete calibration procedure	Calibration mode enabled	Advisory	Calibration enabled selected from the calibrate screen.	Complete calibration procedure.
17	Drive Fault, Cycle Power	Motor drive is disabled	Alarm	Various conditions.	Cycle Power verify motor torque during dispense.
18	Calibration out of range	Calibration values are out of range or flow rate is too low for current K factor	Advisory	Improper calibration, flow rate too low, or pump wear.	Perform calibration procedure.

Maintenance



Prior to performing any maintenance procedures, follow the **Pressure Relief Procedure** on page 26.

Maintenance Schedule

The following tables list the recommended maintenance procedures and frequencies to operate the equipment safely. The maintenance is divided between mechanical and electrical tasks. Maintenance must be performed by trained personnel per this schedule to assure safety and reliability of the equipment.

Mechanical

Operator	Maintenance Person
----------	--------------------

Task	Daily	Weekly	Monthly	3-6 months or 125,000 cycles	18-24 months or 500,000 cycles	36-48 months or 1,000,000 cycles	As Required
Inspect system for leaks	✓						
Depressurize fluid, after operation	✓						
Remove heat from system, after operation	✓						
Inspect filter (234967) bowls and drain		✓					
Check hoses for wear		✓					
Check/tighten fluid connections		✓					
Check/tighten air connections		✓					
Lubricate dispense valves*			✓				
Replace gear meter seals							✓
Rebuild dispense valve*				✓			
Replace air filter					✓		
Replace Solenoid						✓	
Replace gear meter drive shaft							✓
Replace gear head						✓	

* Check component manual for more detailed maintenance information.

Electrical

Task	Weekly
Check cables for wear	✓
Verify cable connections	✓
Verify operation of "System Stop" button	✓

* Check Component Manual for more detailed maintenance information.

Repair

NOTE: Refer to Parts section beginning on page 49 for part reference number identification.

Gear Meter Assembly



This section describes how to remove and replace components on the gear meter assembly.

Prepare Gear Meter Assembly for Repair

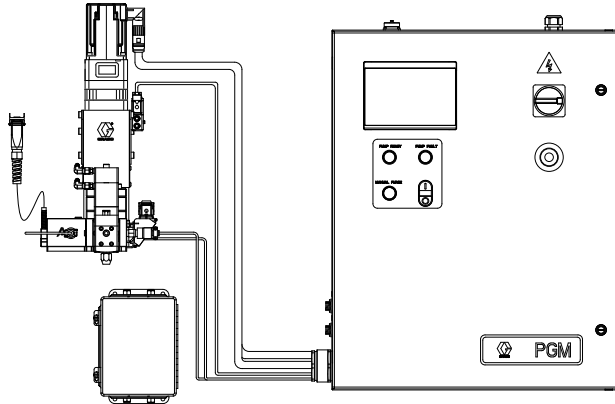

FIG. 18

1. Perform **Pressure Relief Procedure**, page 26.
2. Disconnect main power at the control box.
3. If present, remove power from the heat control.
4. Remove servo power cable and servo feed back cable. See gear meter assembly parts; see **Parts** section starting on page 49.
5. Remove heat cables.
6. Remove pressure transducer cables and dispense valve cable.
7. Remove supply air pressure from solenoid.
8. Remove front guard.
9. Remove material hoses if necessary.

Replace Servo Motor or Gear Head

Replacing either the Servo Motor or Gear Head requires the following procedure.

Remove Servo Motor and Gearhead

1. Prepare gear meter assembly for repair.
2. Remove support gussets (9, 1106).
3. Remove bolts (1, 1103) connecting top mounting plate (8, 1105) to vertical mounting plate (10, 1107).
4. Remove servo motor, gear head, and top plate. Coupling (303, 1203) will separate.
5. Remove coupling half.
6. Remove 4 screws (3, 1110) that mount to plate to gear head.
7. Remove gear head coupling covers (302a, 1202a).
8. Loosen gearhead coupling on gearhead shaft.
9. Remove 4 bolts connecting servo motor to gearhead.
10. Remove servo motor from gear head.

Install Servo Motor or Gearhead

1. Remove key from motor shaft.

NOTICE

Use caution when handling servo motor to prevent damage. Do not use tools that could cause damage.

2. Slide the gear head, bushing into the drive coupling and align slots in drive coupling and bushing. See FIG. 19.

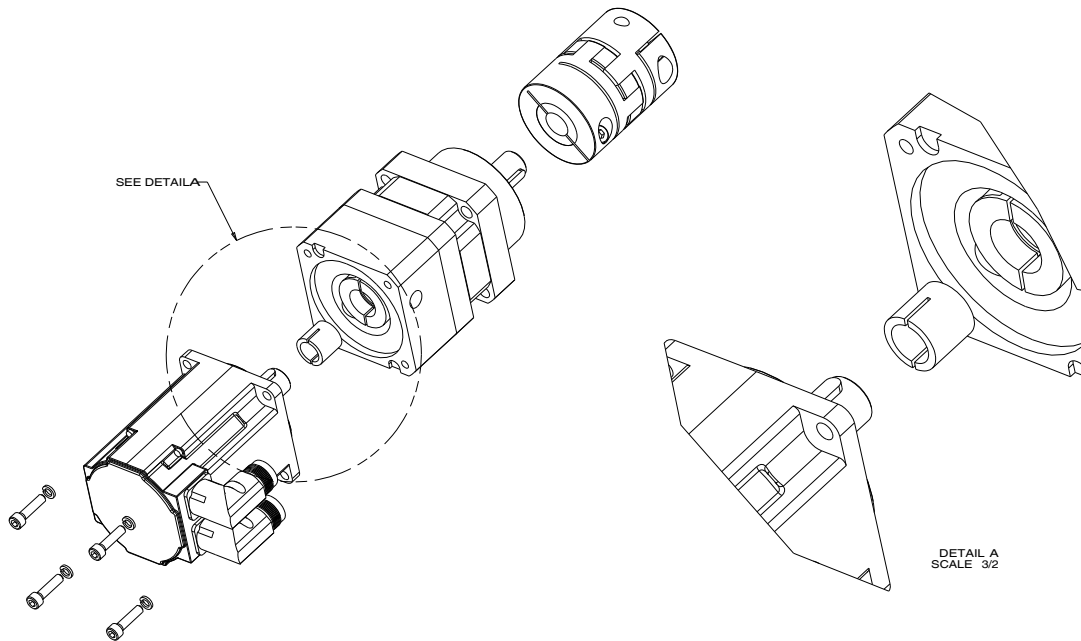

FIG. 19

3. Rotate the drive coupling to align clamping bolts with access holes.
4. Place motor on work surface with motor shaft facing straight up then mount the gear head. Mounting the gear head in any other orientation will usually lead to misalignment and excessive noise.
5. Pre-torque drive coupling to 0.4 N•m (4 in-lb).
6. Bolt gear head to the motor with fasteners provided.
7. Final torque drive coupling to 8.5 N•m (76 in-lb) in three steps increasing torque each time.
8. Do not tighten coupling to gear head output shaft until drive assembly is mounted in frame.

NOTE: Orient servo motor so that the motor connections do not interfere with material inlet hose.

9. Install gussets with shoulder bolts (5, 1104).

Remove Coupling

1. Prepare Gear Meter Assembly for Repair, page 35.
2. Remove support gussets (9, 1106).
3. Remove bolts (1, 1103) connecting top mounting plate (8, 1105) to vertical mounting plate (10, 1107).
4. Remove servo motor, gear head, and top plate.

- Loosen clamping bolts on each side of coupling and remove coupling.

NOTE: Pump shaft key may fall out during coupling removal. Secure pump shaft key until coupling is replaced.

Install Coupling

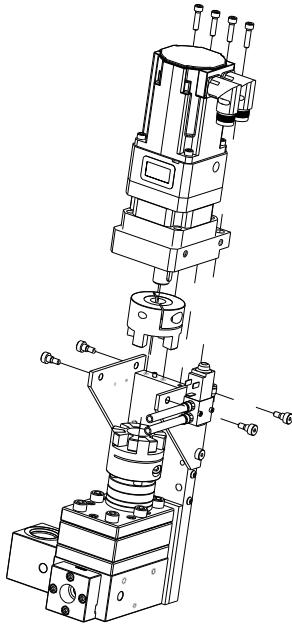

FIG. 20

- Slide coupling onto gear head output shaft. Tighten coupling bolt just enough to hold it's position.
- Align pump shaft key and slide coupling onto pump shaft. Tighten coupling bolt just enough to hold it's position.
- Attach servo motor, gear head, and top plate to pump assembly. See FIG. 20.
- Slide drive coupling so it is evenly spaced between pump and gearhead. Both sides of coupling should slide easily on each shaft. If coupling does not slide freely, loosen pump bolts (103, 1303) and align pump until coupling moves freely. Tighten pump to pump block to 430-480 in-lb (48.58-54.23 N•m).

- Separate coupling until proper gap is created. FIG. 21. See the following table.

Pump Size cc / revolution	Gap (mm)
6	18
20	20

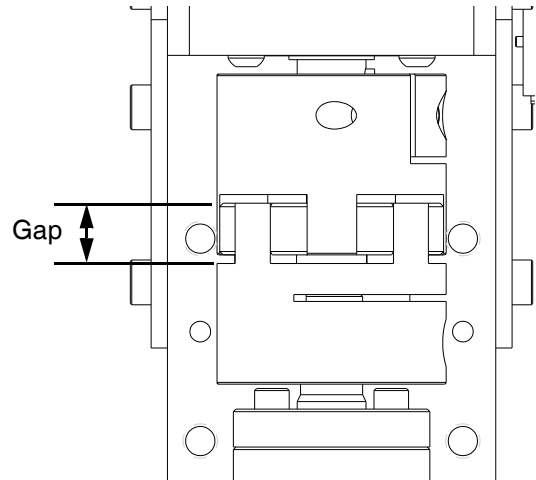

FIG. 21

- Tighten coupling bolts to the following torques:

Pump Size cc / revolution	Torque, in-lb (N•m)
6	132 (15)
20	309 (35)

- Install gussets with shoulder bolts (5, 1104).

Remove Dispense Valve

1. **Prepare Gear Meter Assembly for Repair**, page 35.
2. Manually actuate solenoid to ensure pressure has been removed.

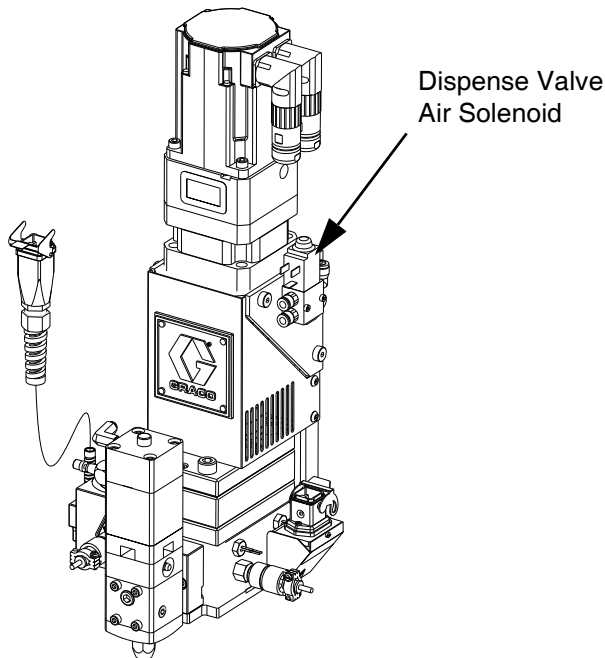

FIG. 22: Dispense Valve Air Solenoid

3. Verify air supply is off.
4. Remove air lines from dispense valve.
5. Remove four dispense valve mounting bolts and remove dispense valve.

NOTE: For remote mount dispense valves, remove supply hose at inlet block of dispense valve.

6. Refer to dispense valve manual for complete dispense valve repair instructions; refer to **Related Manuals** on page 3.

Install Dispense Valve

1. For direct mounted dispense valves, replace o-ring (409) if necessary.
2. Align dispense valve with mounting pins on front block.
3. Install four mounting bolts (408) torque to 50-60 in-lb (5.6-6.7 N•m).

4. Connect air lines.
5. Apply air to the solenoid.
6. Manually shuttle solenoid, see FIG. 22. Verify dispense valve is open when solenoid is depressed.

Replace Solenoid

1. **Prepare Gear Meter Assembly for Repair**, page 35.
2. Disconnect solenoid cable. Remove mating screws (405) from gusset.
3. Remove the dispense valve solenoid (410) and replace it with a new solenoid.
4. Reconnect solenoid cable.

Gear Meter O-Ring Replacement

Refer to **Parts** section starting on page 49 for o-ring kits.

1. **Prepare Gear Meter Assembly for Repair**, page 35.
2. Remove pump block shoulder bolts (4, 1102). See FIG. 23.

NOTICE

Pump section should be fully supported to prevent damage being dropped. It is recommended that the gear meter assembly be located on a work bench for service.

3. Remove drive assembly. See FIG. 23.

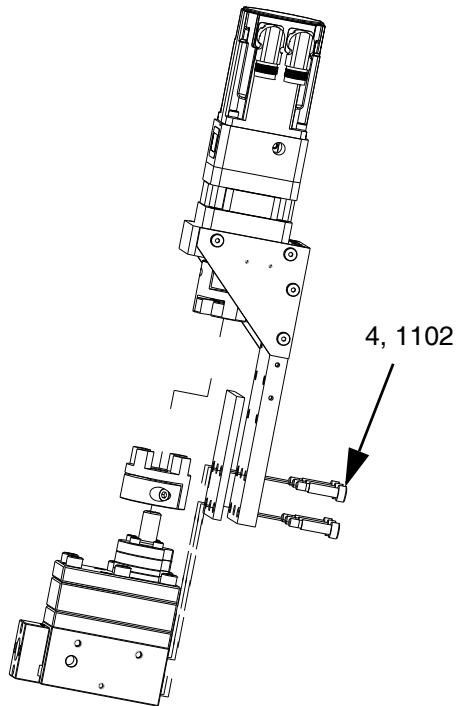
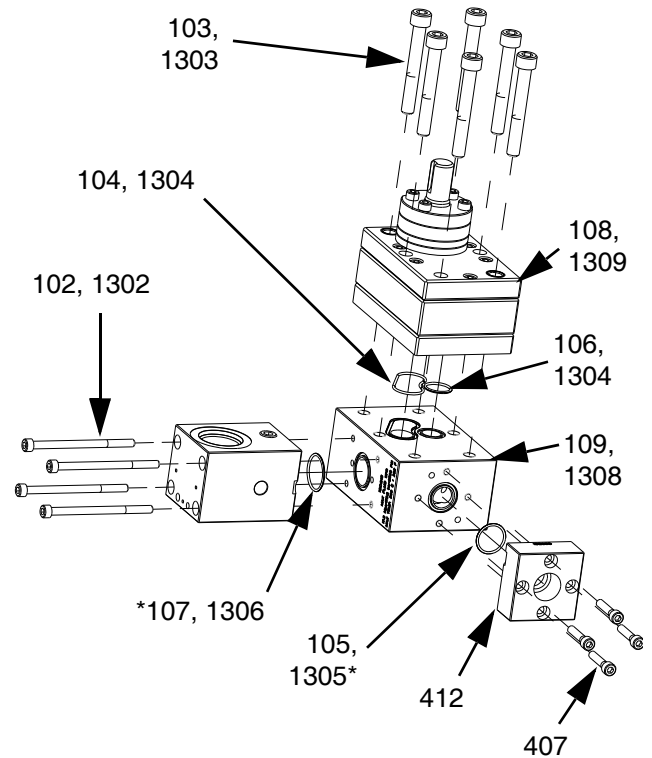

FIG. 23

4. Perform **Remove Dispense Valve** procedure.
5. Loosen 4 bolts (407) and remove front block (412).
6. Loosen 4 bolts and remove inlet block (110, 1302).
7. Loosen pump bolts (3, 1303) and remove pump (108, 1309).
8. Replace front block o-ring (105, 1305).
9. Install front block (412) onto pump block (109, 1308).
10. Replace inlet block o-ring (107, 1306).
11. Install inlet block (102, 1302) onto pump block.

12. Replace pump block o-rings (106, 104; 1304). See FIG. 24.



* Provided in o-ring kit 24E626.

FIG. 24

13. Place pump (109, 1308) onto pump block. Install bolts (103, 1303) and tighten to 430 in-lb (48.58 N•m).
14. Locate drive assembly on top of pump assembly.
15. Tighten pump block mounting shoulder bolts to frame (4, 1102).
16. Replace all electrical connections and fluid connections before applying fluid pressure and power.

PGM-6 Pump Repair

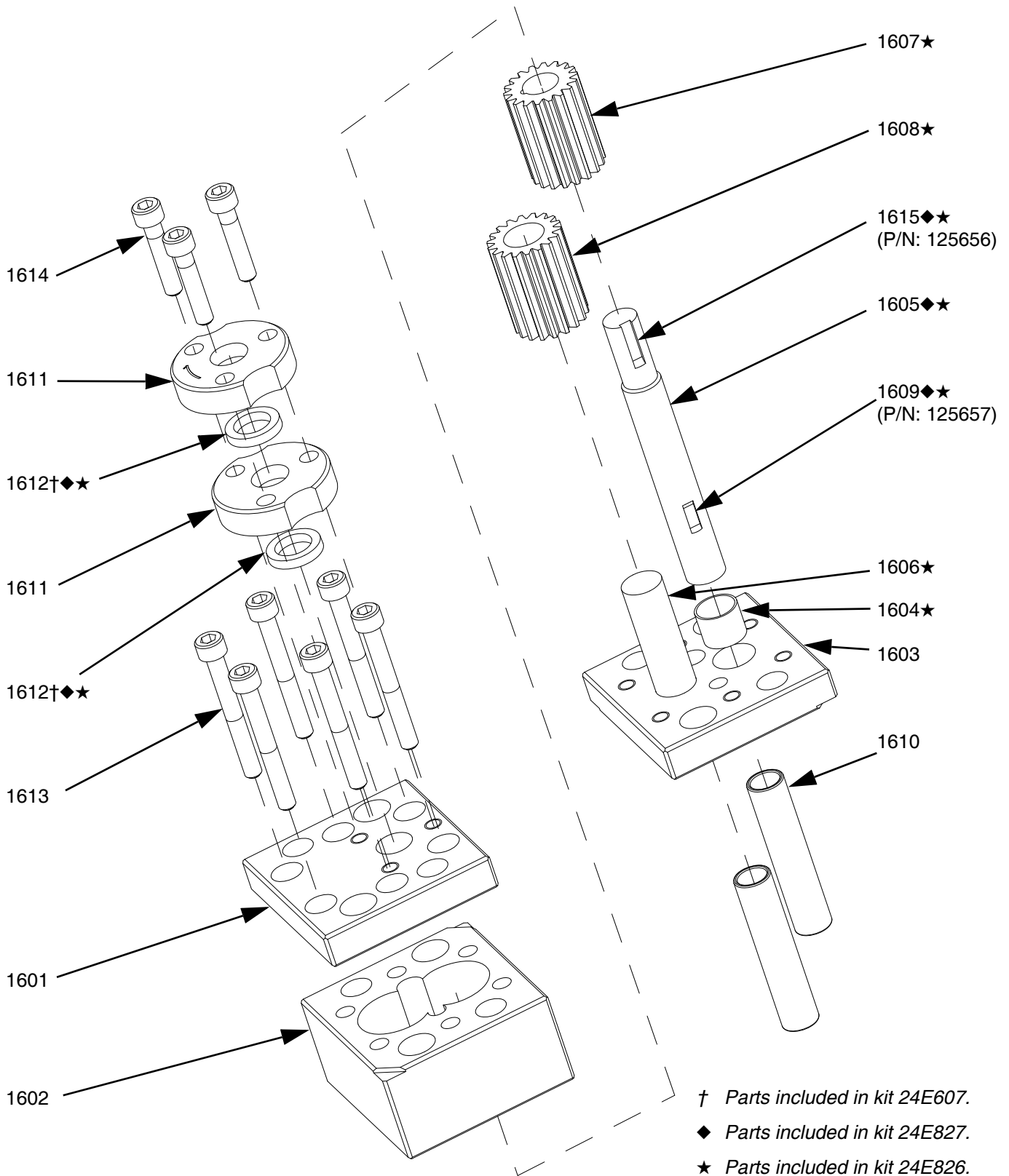

FIG. 25: PGM-6

PGM-6 Pump Disassembly

1. Prepare Gear Meter Assembly for Repair, page 35.
2. Refer to **Gear Pump Maintenance Guide** on page 47 for special notes regarding gear pump repair.
3. Remove four pump block shoulder bolts (1102).

NOTICE

Pump section should be fully supported to prevent damage being dropped. It is recommended that the gear meter assembly be located on a work bench for service.

4. Remove drive assembly. See FIG. 23.



NOTICE

Thicker materials may require heating prior to disassembly. Do not expose the pump to thermal shock. Raise temperature at a maximum rate of 180°F (100°C) per hour. Do not exceed 400°F (204°C). Exceeding this temperature could promote leakage in the pump. Gradually cool the pump to room temperature.

5. Remove seal retainer fasteners (1614) and seal retainers (1611).
6. Remove pump dowel pins (1610) using an arbor press.

NOTICE

Do not use a hammer to remove dowel pins as this will damage the pump.

7. Remove the pump plate screws (1613).
8. Separate the pump front plate (1601), gear case (1602) and back plate (1603).

NOTE: Notches on the pump plates can be used to separate the plates.

9. To remove the drive shaft (1605) from the bottom plate (1603) press the shaft and gear from the bottom pump plate towards the coupling end.
10. To remove the drive gear (1607) from the drive shaft (1605), support the drive gear at the lower end to allow the shaft to be pressed through the gear from the top or coupling end. Make sure to leave clearance for the drive key.
11. The stud (1606) for the driven gear (1608) is press fit into the back plate (1603) and need not be removed if not worn.

NOTICE

The PGM pump design relies on a lap fit between components for performance and sealing. Be careful not to drop the gears (1607, 1608) or damage the mating surfaces of the pump plates (1601, 1603) and gear case (1602). To prevent damage, do not use pliers or screwdrivers to remove the gears.

12. Clean all components thoroughly before reassembly. The use of an ultrasonic cleaner is recommended.

PGM-6 Pump Assembly

NOTICE

Do not hammer or force components together or damage may occur. Parts will drop into place if properly cleaned and aligned. Use of a compatible oil is recommended during assembly.

1. Place the back plate (1603) on a table inside facing up.
2. Place the driven gear (1608) on its stud (1606).
3. Place gear case (1602) onto back plate (1603). Check orientation of dowel pin holes to assure they align with the ones in the back plate.
4. Slide drive gear (1607) onto drive shaft (1605). Verify shaft key (1609) is installed properly.
5. Install drive gear (1607) and drive shaft (1605) into back plate (1603).
6. Position top plate (1601) over drive shaft (1605) and place onto gear case (1602).
7. Rotate the gears several times to ensure free rotation.
8. Insert the dowel pins (1610) and rotate the gears several times to ensure free rotation.

NOTE: Dowel pins are not a press fit and may be installed using a plastic hammer if necessary.

9. Install pump plate screws (1613) and tighten to 85-105 in-lb (9.6-11.8 N•m).
10. Rotate the gears several times to ensure free rotation.
11. Apply a heat resistant, non-evaporating lubricant to the seal area of the drive shaft (1605).

12. Install new seals (1612). See FIG. 26 and FIG. 27.

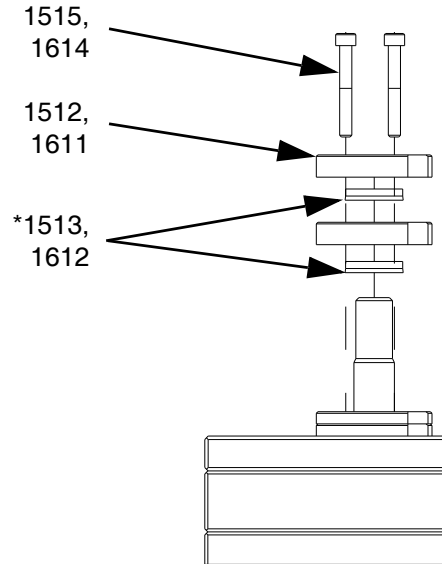

FIG. 26: Seal Locations



FIG. 27: Seal Orientation

13. Install seal retainers (1611) and seal retainer screws (1614). Tighten screws to 85-105 in-lb (9.6-11.8 N•m).
14. Align pump shaft key and slide coupling onto pump shaft. Tighten coupling bolt just enough to hold it's position.
15. Attach servo motor, gear head, and top plate to pump assembly. See FIG. 20.
16. Separate coupling until proper gap is created. See FIG. 21.
17. Tighten pump block mounting shoulder bolts to frame (1102).
18. Replace all electrical connections and fluid connections before applying fluid pressure and power.

PGM-20 Pump Repair

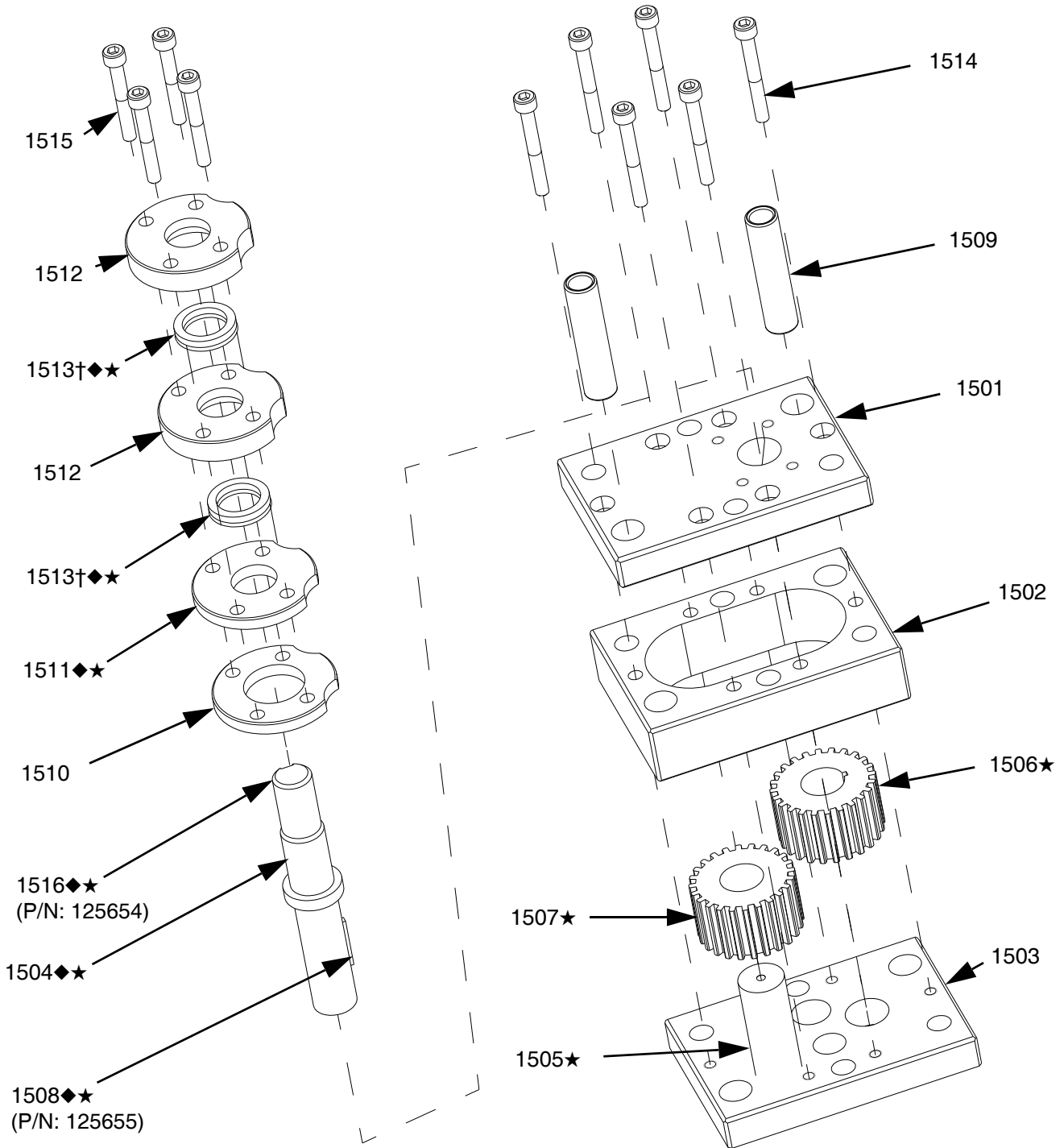

† Parts included in kit 24E619.

◆ Parts included in kit 24E825.

★ Parts included in kit 24E824.

FIG. 28: PGM-20

PGM-20 Pump Disassembly

1. Prepare Gear Meter Assembly for Repair, page 35.
2. Refer to **Gear Pump Maintenance Guide** on page 47 for special notes regarding gear pump repair.
3. Remove six pump block shoulder bolts (4).

NOTICE

Pump section should be fully supported to prevent damage being dropped. It is recommended that the gear meter assembly be located on a work bench for service.

4. Remove drive assembly. See FIG. 23.



NOTICE

Thicker materials may require heating prior to disassembly. Do not expose the pump to thermal shock. Raise temperature at a maximum rate of 180°F (100°C) per hour. Do not exceed 400°F (204°C). Exceeding this temperature could promote leakage in the pump. Gradually cool the pump to room temperature.

5. Remove seal retainer fasteners (1515) seal retainers (1512), spacers (1510) and (1511).
6. Remove pump dowels (1509) using an arbor press.

NOTICE

Do not use a hammer to remove dowel pins as this will damage the pump.

7. Remove the pump plate screws (1514).
8. Separate the pump front plate (1501), gear case (1502) and back plate (1503).

NOTE: Notches on the pump plates can be used to separate the plates.

9. To remove drive shaft (1504) from the drive gear (1506) several flat spacers 1/8 in. (3 mm) thick will

be needed. These will provide clearance for the drive shaft key (1508) and the top plate (1501).

10. Support pump top plate (1501) and press drive shaft (1504) through drive gear (1506). Stop when there is enough clearance between the drive gear (1506) and top plate (1501) to insert one spacer. Be sure to allow clearance for drive key (1508).
11. Continue pressing the drive shaft (1504) and inserting spacers until the shaft is free from the drive gear (1506).
12. The stud (1505) for the driven gear (1507) is press fit into the back plate (1503) and need not be removed if not worn.

NOTICE

The PGM pump design relies on a lap fit between components for performance and sealing. Be careful not to drop the gears (1607, 1608) or damage the mating surfaces of the pump plates (1601, 1603) and gear case (1602). To prevent damage, do not use pliers or screwdrivers to remove the gears.

13. Clean all components thoroughly before reassembly. The use of an ultrasonic cleaner is recommended.

PGM-20 Pump Assembly

NOTICE

Do not hammer or force components together, or damage may occur. Parts will drop into place if properly cleaned and aligned. Use of a compatible oil is recommended during assembly.

1. Place back plate (1503) on a table inside face up.
 2. Install the driven gear (1507) on stud (1505).
 3. Place gear case (1502) onto back plate (1503). Check orientation of dowel pin holes to assure they align with the ones in the back plate.
 4. Place the top plate (1501) on its edge on a table. Pass the drive shaft (1504) through the top plate from the seal side so that the boss on the shaft rests on the top plate.
 5. Rotate the drive shaft (1504) to position the drive key slot at the top. Insert the drive key (1508) and driven gear (1506).
 6. Grasp the top plate (1501), drive shaft (1504) and driven gear (1506) to prevent them from separating and carefully lower them into position onto the gear case (1502).
 7. Rotate the gears several times to ensure free rotation.
 8. Insert the dowel pins (1509) and check again for free rotation.
- NOTE: Dowel pins are not a press fit and may be installed using a plastic hammer if necessary.**
9. Install pump plate screws (1514) and tighten to 85-105 in-lb (9.6-11.8 N•m).
 10. Rotate the gears several times to ensure free rotation.
 11. Apply a heat resistant, non-evaporating lubricant to the seal area of the drive shaft (1504).
 12. Install new seals (1513). See FIG. 26 and FIG. 27.
 13. Install spacers (1510, 1511), seal retainers, (1512) and seal retainer screws (1515). Tighten screws to 85-105 in-lb (9.6-11.8 N•m).
 14. Align pump shaft key and slide coupling onto pump shaft. Tighten coupling bolt just enough to hold it's position.
 15. Attach servo motor, gear head, and top plate to pump assembly. See FIG. 20.
 16. Separate coupling until proper gap is created. See FIG. 21.
 17. Tighten pump block mounting shoulder bolts to frame (4).
 18. Replace all electrical connections and fluid connections before applying fluid pressure and power.

Gear Pump Maintenance Guide

Review these guidelines prior to performing any maintenance on the pumps.

- Do not run pump dry.
- Do not pull from a vacuum or negative suction head.
- Do not flush with water or other non-lubricating fluid.
- Do not pump corrosives, abrasives and/or fluids carrying particles that may harm the pump.
- Do not heat or cool pump faster than 180°F (100°C) per hour.
- Do not drop disassembled parts on a hard surfaces and do not let parts knock together.
- Never strike the pump parts with an iron hammer. The parts are designed to drop in place if properly aligned. Use arbor press to insert or remove press fit components.
- Do not use pliers to lift the gears.
- Never use a screwdriver to pry the gears upward.
- Apply clean oil or compatible fluid during assembly.

Installing new heater units and RTD sensors

1. Prepare Gear Meter Assembly for Repair, page 35.

2. Disconnect the power cables from the heaters.

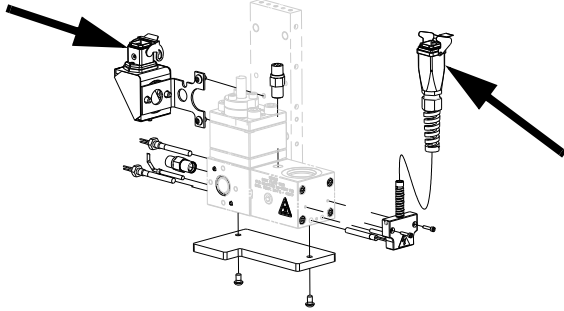

3. Remove two M3 screws to remove the kit from the inlet block.

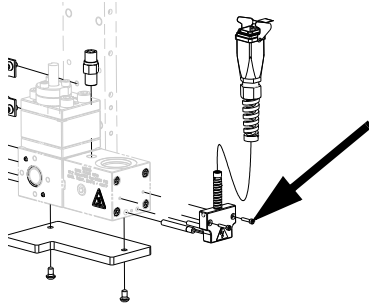

4. Remove two M6 screws to remove the kit from the pump block.

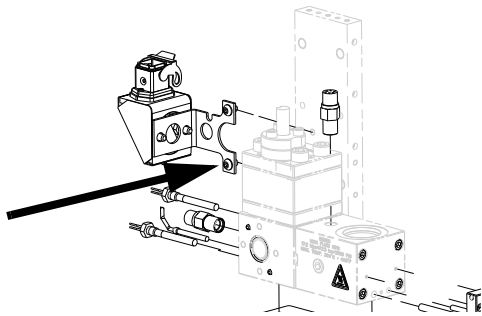

5. Remove the two M8 heater nuts and M6 sensor nut.

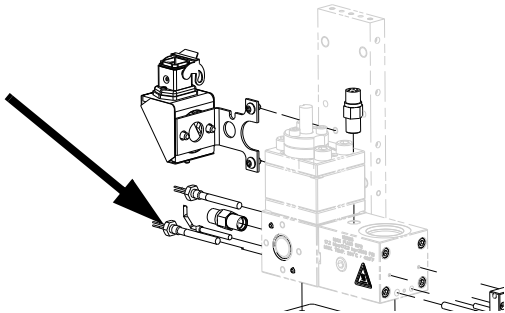

6. Remove the heaters and sensor from the block.

NOTICE

The heaters may be difficult to remove and removal depends on the system type. To ensure proper heat transfer and to avoid premature heater failure,

System with through hole:

Press out the heater element using an 0.125" (3 mm) diameter pin.

System without through hole:

Drill out the heater element using a 5mm (0.203 in.) drill bit. Do not increase the hole diameter.

7. Clean any residue from both heater and sensor ports.

8. Installation is the reverse of removal.

Parts

PGM-20 Mounting Frame

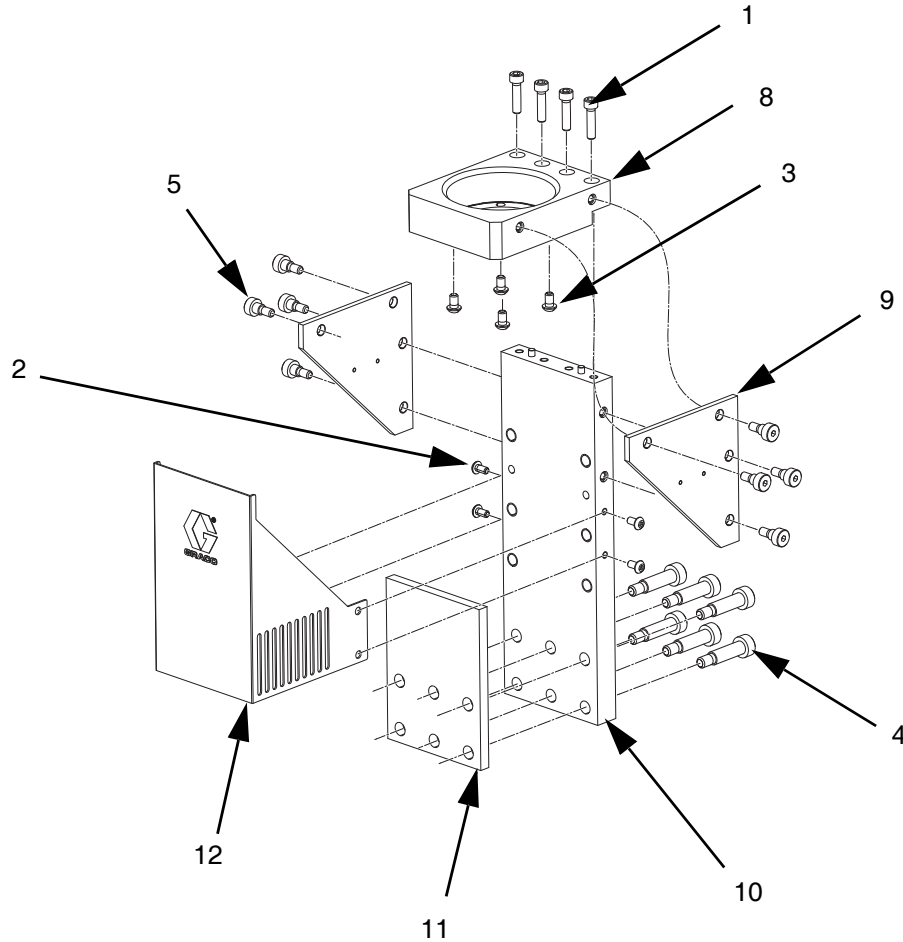

ti21285a

Ref	Part	Description	Qty
1	124164	SCREW, shcs, M6-1.0 x 25	4
2	124165	SCREW, bhcs, M5-0.6 x 10	4
3	124166	SCREW, bhcs, M6-1.0 x 10	4
4	124167	SCREW, shoulder, 10x30, M8-1.25	6
5	124168	SCREW, shoulder, 8 x 6, M6-1.0	8
8	16D840	PLATE, mounting	1
9	16D841	GUSSET	2
10	16D842	PLATE	1
11	16D843	INSULATOR	1
12	16V444	GUARD, drive	1

PGM-20 Lower Assembly Block

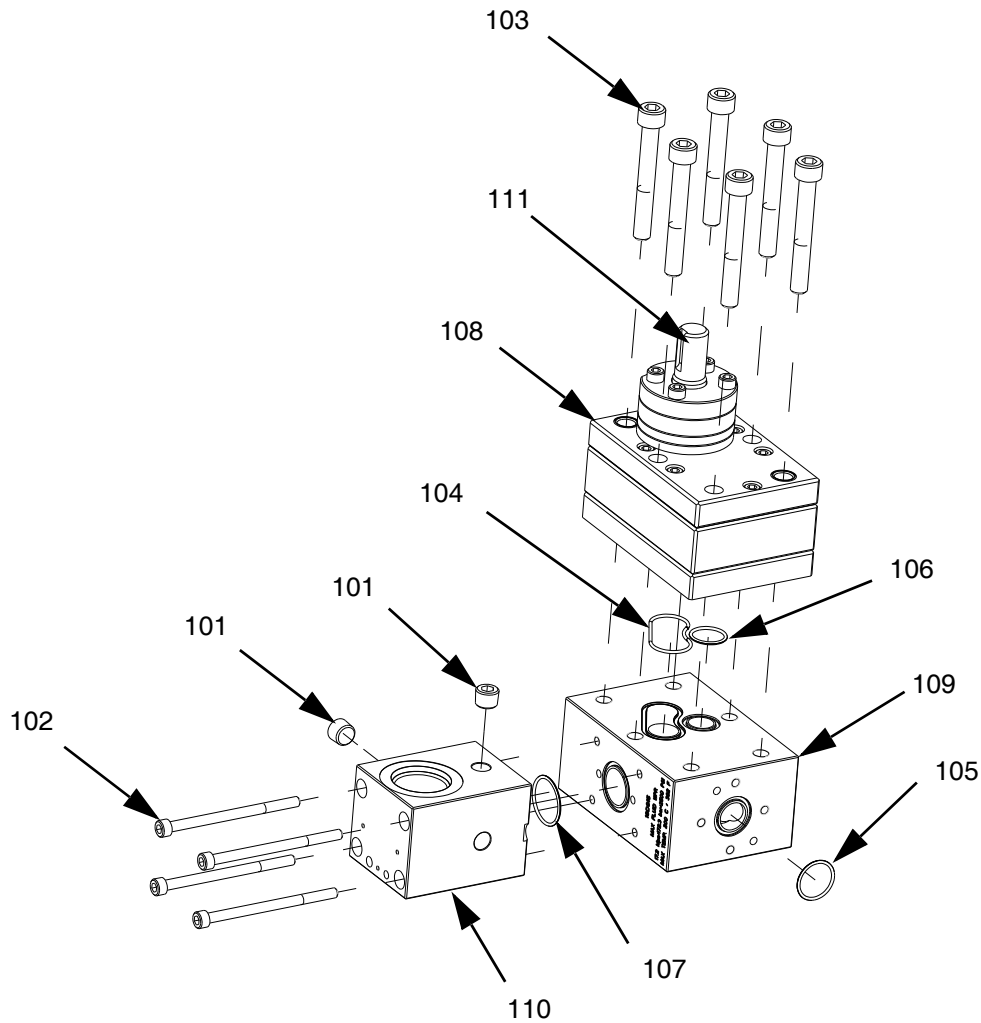

Ref	Part	Description	Qty
101	101970	PLUG, pipe, headless	2
102	124173	SCREW, M6-1.0 x 90	4
103	124174	SCREW, M10-1.5 x 75	6
104†		O-RING	1
105†		PACKING, o-ring	1
106†		PACKING, o-ring	1
107†		PACKING, o-ring	1
108*	16D827	METER, gear, precision, 20cc/rev	1
109	16D915	BLOCK, pump, mounting	1
110	16D916	BLOCK, inlet, PGM	1
111†		DRIVE KEY	1

† Part included in o-ring kit 24E626, or drive key kit 25E205.

* For part breakdown and repair kits, refer to **PGM-20 Pump Repair**, page 44.

PGM-20 Pump Heat Kit

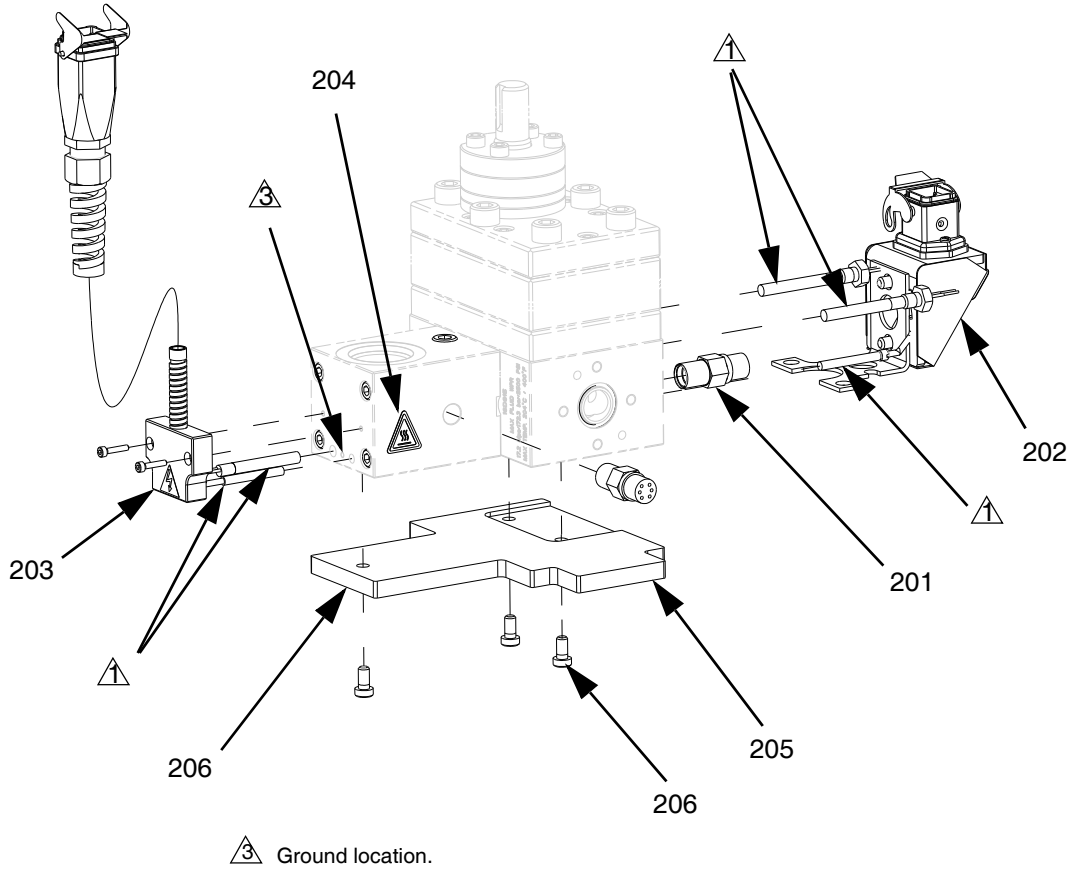

Ref	Part	Description	Qty
201	117764	SENSOR, pressure	2
202	24E412	KIT, heat, pump, PGM-20	1
203	24E413	KIT, heat, PGM, inlet	1
204▲	125363	LABEL, heat/burn, warning	2
205	16D923	INSULATOR	1
206	124175	SCREW	3

▲ Replacement Danger and Warning labels, tags, and cards are available at no cost.

PGM Drive - 20 cc Pump

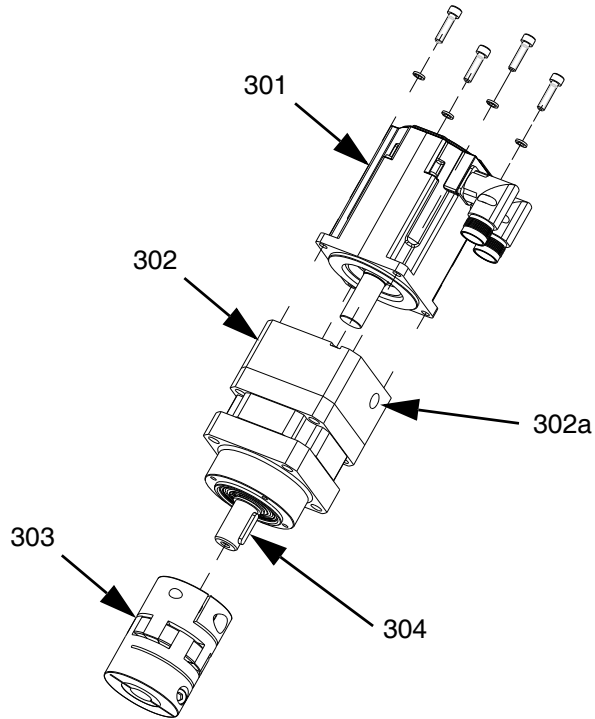

Ref	Part	Description	Qty
301	16D947	MOTOR, PGM drive, servo, 4 frame	1
302	16D946	GEAR REDUCER, PGM drive, 50:1, 80mm frame	1
302a		COVER	1
303	16D945	COUPLING, PGM drive, 18x20mm	1
304†		DRIVE KEY	1

† Part included in drive key kit 25E205.

EnDure Dispense Valve Fix Mounted

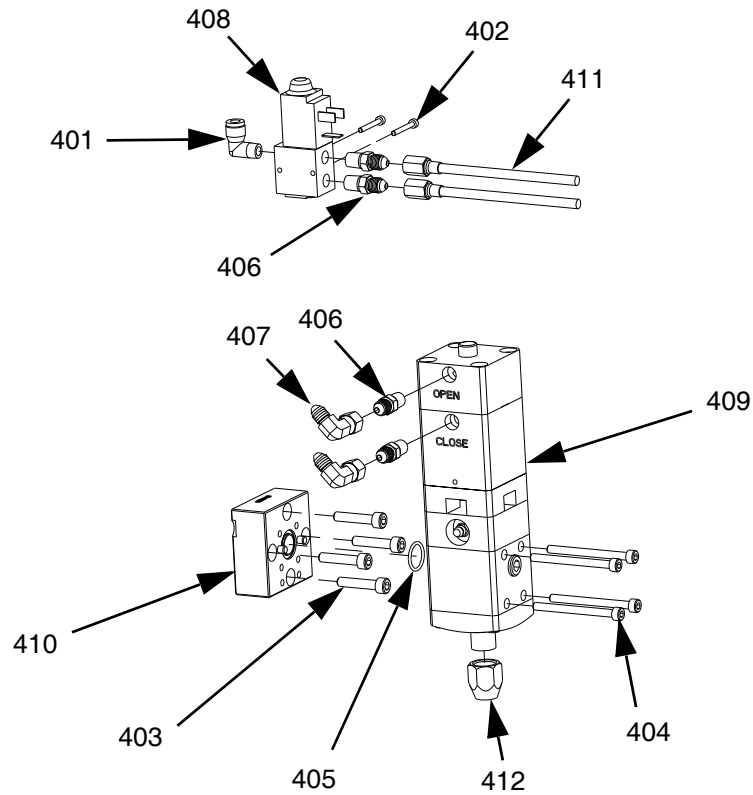

Ref	Part	Description	Qty
401	597151	FITTING, elbow, 1/4 tube x 1/8 NPT, male	1
402	117820	SCREW, cap, socket head, M3	2
403	124200	SCREW, socket head cap screw, M6-1.0 x 30, stainless steel	4
404	124201	SCREW, socket head cap screw, M5-0.8 x 60, stainless steel	4
405	116768	PACKING, o-ring	1
406	124403	FITTING, adapter, 1/8 NPTM x 03 JICM, mild steel	4
407	124405	SWIVEL, elbow, 90 deg, 03 JICF x 03 JICM, mild steel	2
408	198446	VALVE, dispense, closer	1
409	244907	VALVE, EnDure	1
410	16D943	BLOCK, mounting	1
411	16E899	HOSE, assembly, stainless steel braid, 3/16 x 12	2
412	C32089	RETAINER, seat	1

Gear Meter Assembly Panel

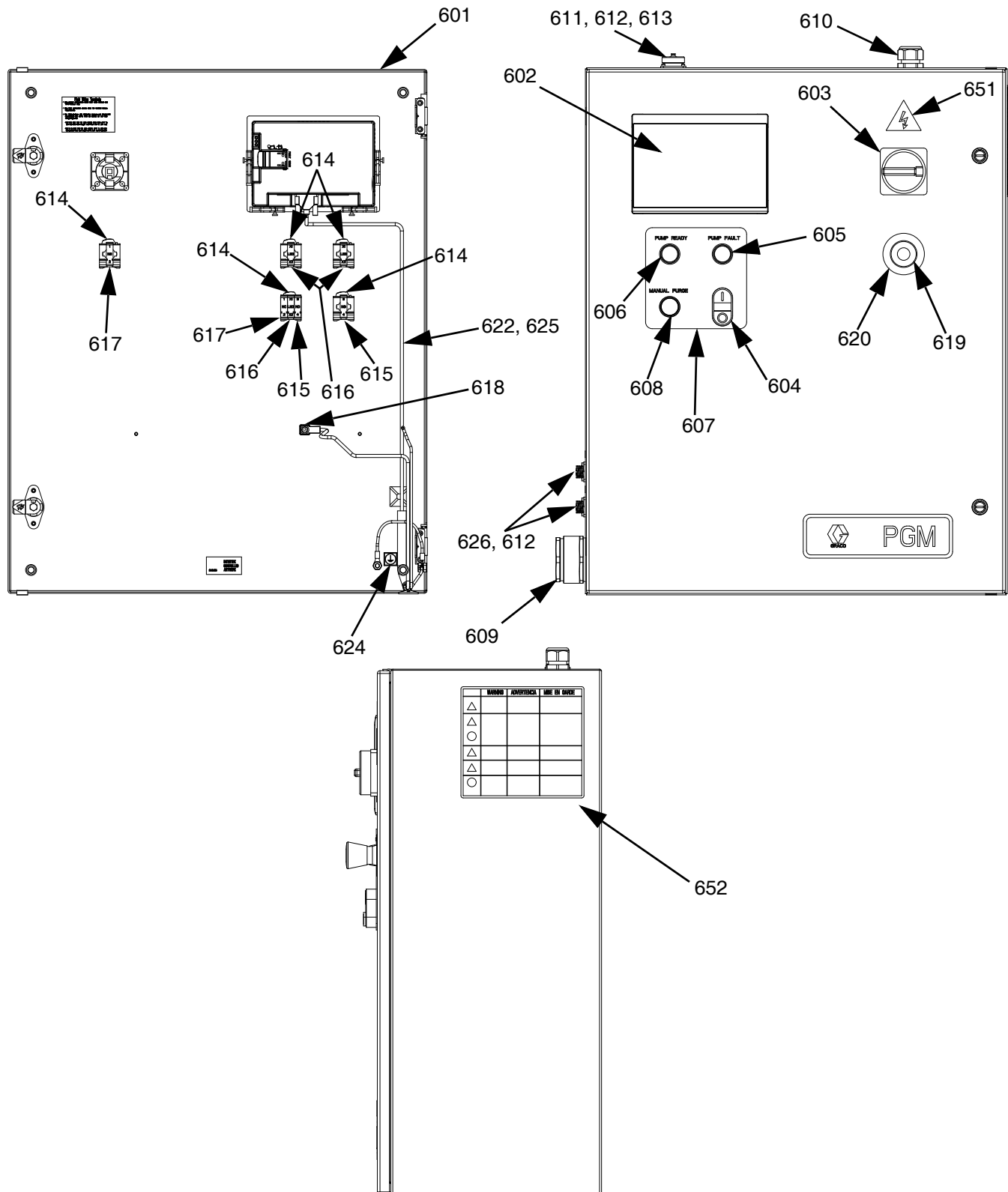

Ref	Description	Qty	Ref	Description	Qty
601	ENCLOSURE, control, gear meter painted	1	615	81/2080- CONTACT, block, no 1/11	2
602	25C836 MODULE, HMI, PGM	1	616	81/2072- LIGHT, led, white, 24vdc, latch 2/11	3
603	121148 HANDLE, disconnect, electric	1	617	81/2081- CONTACT, block, nc 1/11	2
604	81/2060- BUTTON, dual, grn/red, w/pl-wht P/11	1	619	81/2060- BUTTON, mush, maint, twist, red E/11	1
605	81/2065- BUTTON, operator, pl, red R/11	1	620	81/2060- LABEL, legend, e-stop, 60mm EL/11	1
606	81/2065- BUTTON, operator, pl, green G/11	1	622	126987 CABLE, communication	1
607	--- LABEL, legend, panel, PGM	1	624▲	84/0130- LABEL, prot earth(grnd).375x.375 23/11	1
608	16D363 BUTTON, operator, pb, flush, black	1	625	--- STRAP, wrap, spiral, 1/2", nylon	4
609	--- FITTING, bulkhead, gland, 9wire	1	626	81/1060- CONNECTOR, sq, 4p w/key, 7a, 4/25 panel m	2
610	--- GRIP, cord, .35-.63, 3/4	1	651▲	196548 LABEL, caution	1
611	81/1060- CONNECTOR, sq, 14pw/key, 7a, 14/25 panel m	1	652▲	15M511 LABEL, warning, english/spanish/french	1
612	96/0360/ FASTENER, shc, 4-40x0.25, ms, e 12 99	12			
613	--- COVER, dust, amp17 conn w/chain	1			
614	81/2070/ LATCH, operator 11	4			

▲ Replacement Danger and Warning labels, tags, and cards are available at no cost.

Cables

Description	3 Meter	6 Meter	9 Meter	15 Meter
Servo Power Cable	17R673	17R674	17R675	17R676
Feedback Cable	17R677	17R678	17R679	17R680
Dispense Valve	24E571	24E572	24E573	24U020

PGM Back Panel

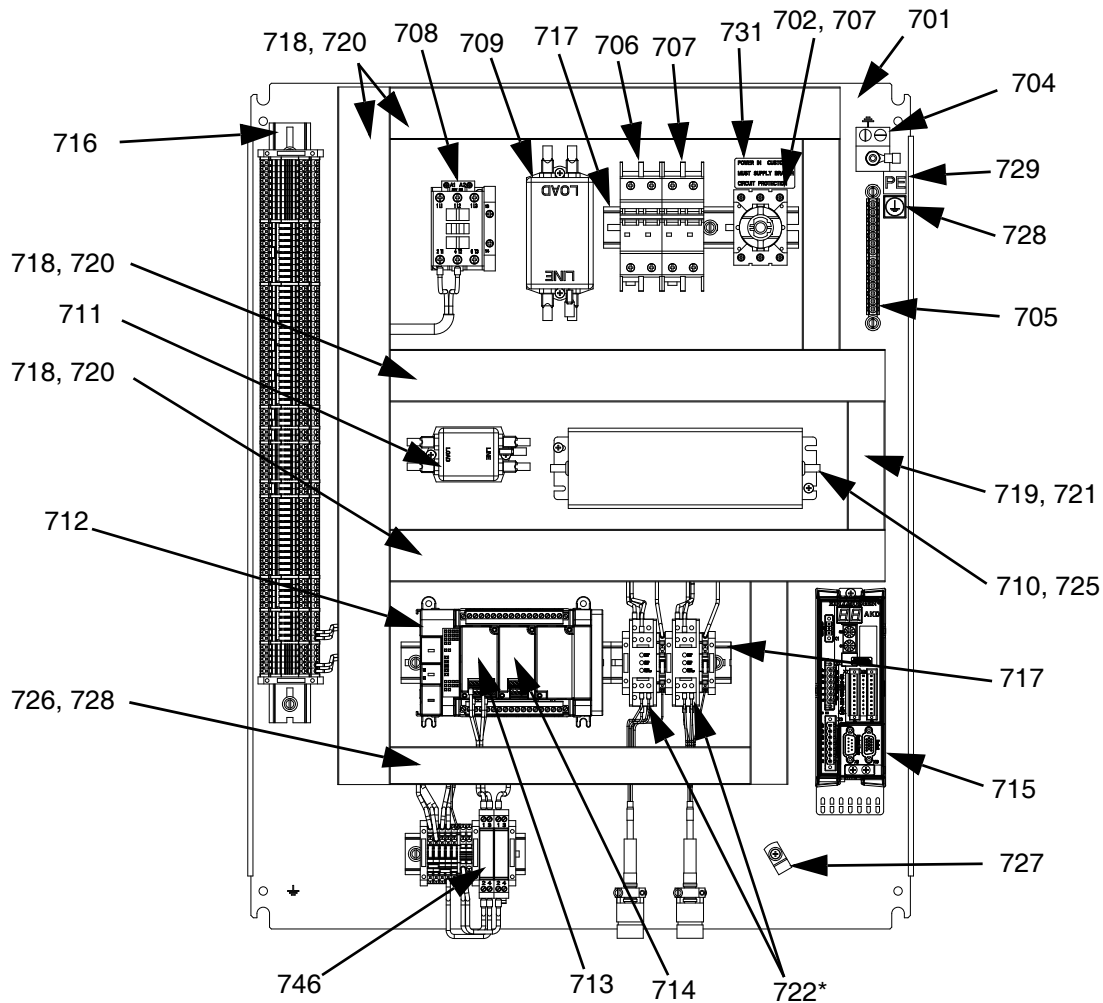

Ref	Part	Description	Qty	Ref	Part	Description	Qty
701	---	PANEL, back, for30x24 encl, conduit	1	711	123718	FILTER, emi, 6a, spade con	1
702	123361	SWITCH, disconnect, 32a	1	712	25M865	MODULE, plc, 14di/10do, 24dc	1
703	124228	EXTENSION, disconnect, 230-350mm	1	713	129709	MODULE, analog in	1
704	117666	TERMINAL, ground	1	714	U70899	MODULE, ana-out	1
705	U70077	TERMINAL, lug, ground, bus type	1	715	25C834	DRIVE, indexer (PGM-06 only)	1
706	123298	CIRCUIT, breaker, 2p, 20a, ul489	1		25C835	DRIVE, indexer (PGM-20 only)	1
707	123296	CIRCUIT, breaker, 2p, 1a, ul489	1	716	---	STRIP, terminal, PGM, control	1
708	123359	RELAY, contactor, 30a, 3p, 24vdc co	1	717	---	RAIL, din	1
709	130185	FILTER	1	718	---	WIREWAY, panduit, 1.5"x3.0"x6'	6
710	121808	POWER SUPPLY, 24vdc, 4.0a, 100w	1	719	---	WIREWAY, panduit, 1"x3"x6'	6
				720	---	COVER, panduit, 1.5"x6'	6
				721	---	WIREWAY, cover, panduit, 1"x6'	6

Ref	Part	Description	Qty	Ref	Part	Description	Qty
722	129710	AMPLIFIER, signal conditioner, PGM (3, 6, or 9 m cables)	2	728▲	84/0130- LABEL, prot earth (grnd).375x.375	23/11	1
725	120997	CABLE, turck, rs 4t-4	1	729▲	84/0130- LABEL, pe	26/11	1
727	---	CLAMP, wire, harness, 1/4, galvaniz	1	746	---	MODULE, varistor	1

▲ Replacement Danger and Warning labels, tags, and cards are available at no cost.

Remote Mount Amplifiers

Only for control centers with 15 m cables.

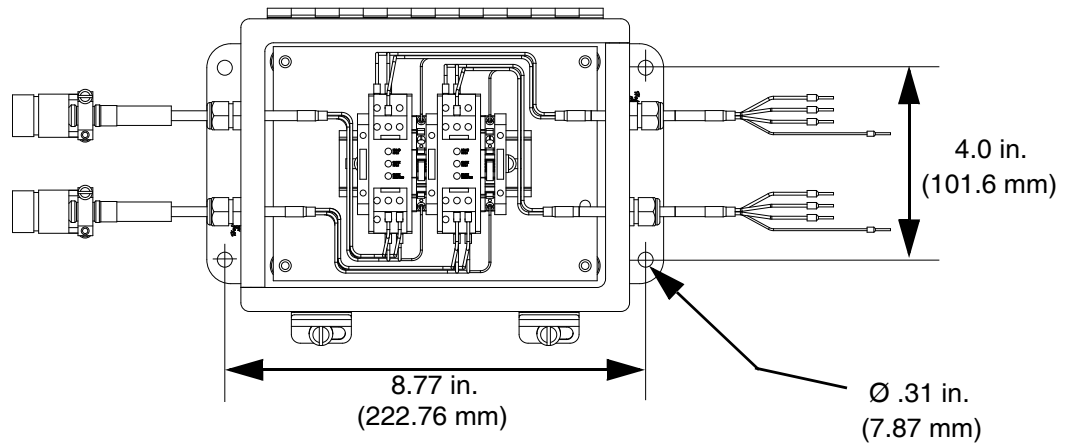

PGM Remote Dispense Valve

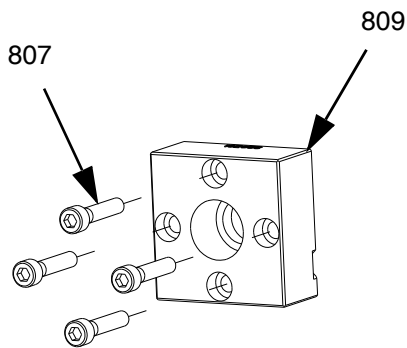
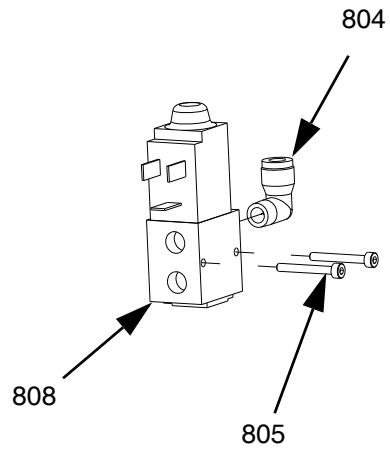

Ref	Part	Description	Qty
804		FITTING	1
805	117820	SCREW, cap, socket head, M3	2
807	124200	SCREW, shsc, M6-1.0 x 30, stainless steel	4
808	198446	VALVE, dispense, closer	1
809	16E055	BLOCK, outlet, PGM, 3/4 NPTF, stainless steel	1

PGM Ambient Transducer 24E474

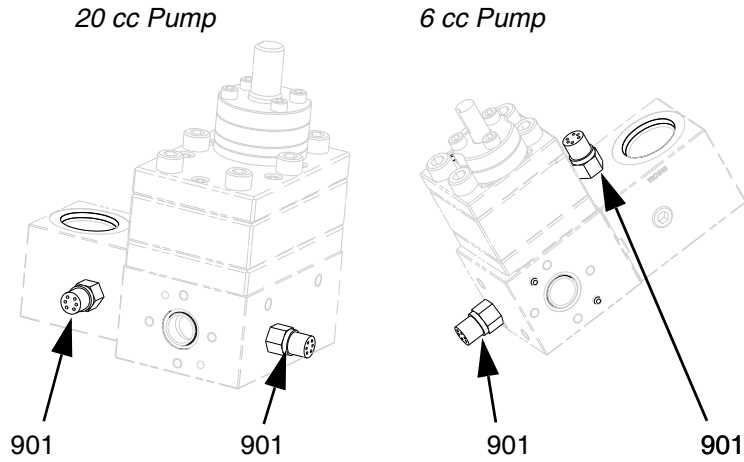

Ref	Part	Description	Qty
901	124517	SENSOR, pressure	2

NOTE: Ambient sensors are used on models PGx1xx (unheated). See technical page for ambient operating temperature range.

PGM Ambient Transducer 25E231

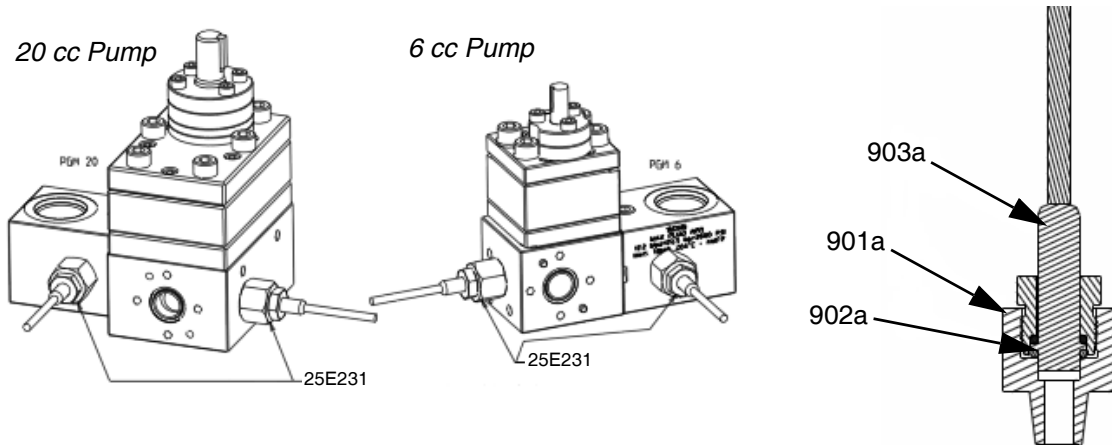

Ref	Part	Description	Qty
901a	17X995	ADAPTER, pressure transducer	2
902a	121399	PACKING, o-ring, 012 f x 75	2
903a	16A093	SENSOR, pressure	2

NOTE: This kit is used for PGM systems that are independent of the Graco PGM control box. Refer to **Appendix D - Transducer 25E231 Connection** on page 102 for information about making connections.

PGM-6 Mounting Frame

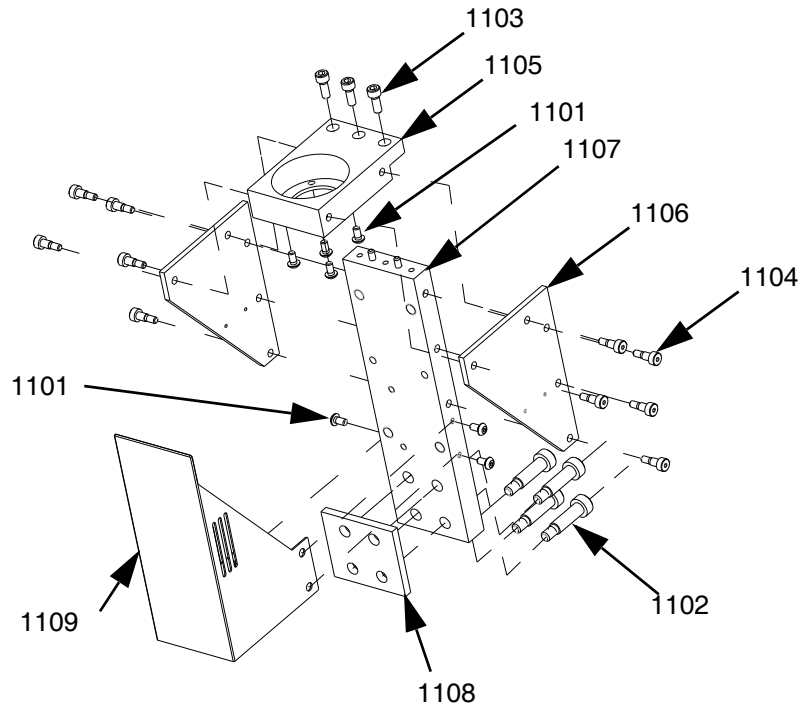

Ref	Part	Description	Qty
1101	124165	SCREW, bhcs, M5-0.8 x 10, stainless steel	7
1102	124167	SCREW, shoulder, 10 x 30, M8-1.25, stainless steel	4
1103	124313	SCREW, shcs, M6-1 x 16 mm, stainless steel	3
1104	124314	SCREW, shoulder, 6 x 8, M5 - 0.8, carbon steel	8
1105	16E327	PLATE, mounting, drive, PGM-6	1
1106	16E328	GUSSET, drive, PGM-6	2
1107	16E329	PLATE, mounting, pump, PGM-6	1
1108	16E330	INSULATOR, pump, PGM-6	1
1109	16E331	GUARD, drive, PGM-6	1

PGM-6 Drive Kit

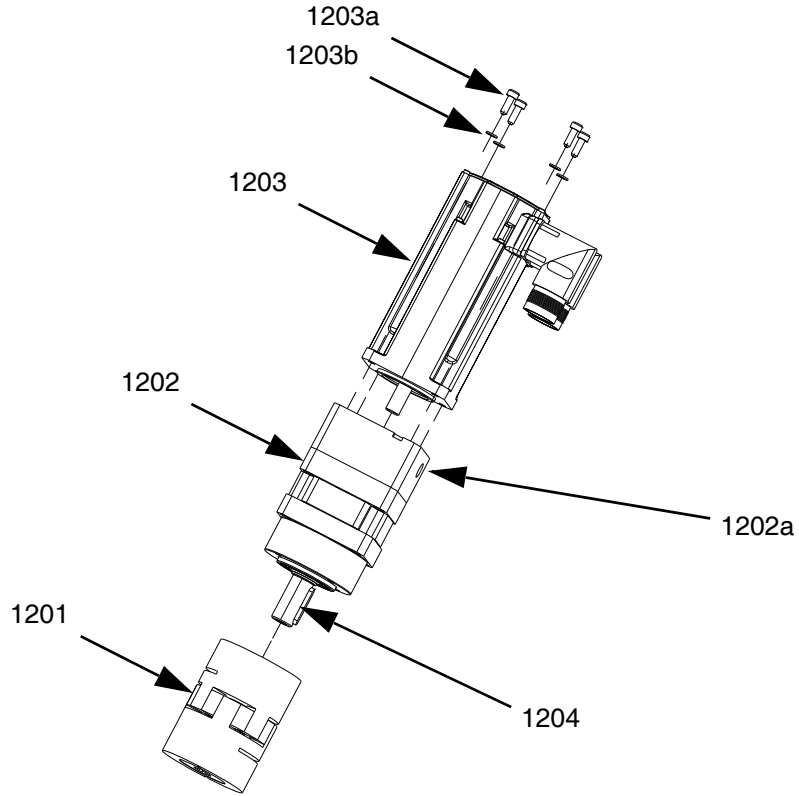

Ref	Part	Description	Qty
1201	16E367	COUPLING, PGM drive, 12 mm x 14 mm	1
1202	16E368	GEAR REDUCER, PGM drive, 50:1, 60 mm frame	1
1202a		COVER	1
1203	16E369	MOTOR, PGM drive, frame	1
1203a		SCREW	4
1203b		WASHER	4
1204†		DRIVE KEY	1

† Part included in drive key kit 25E204.

PGM-6 Lower Assembly Block

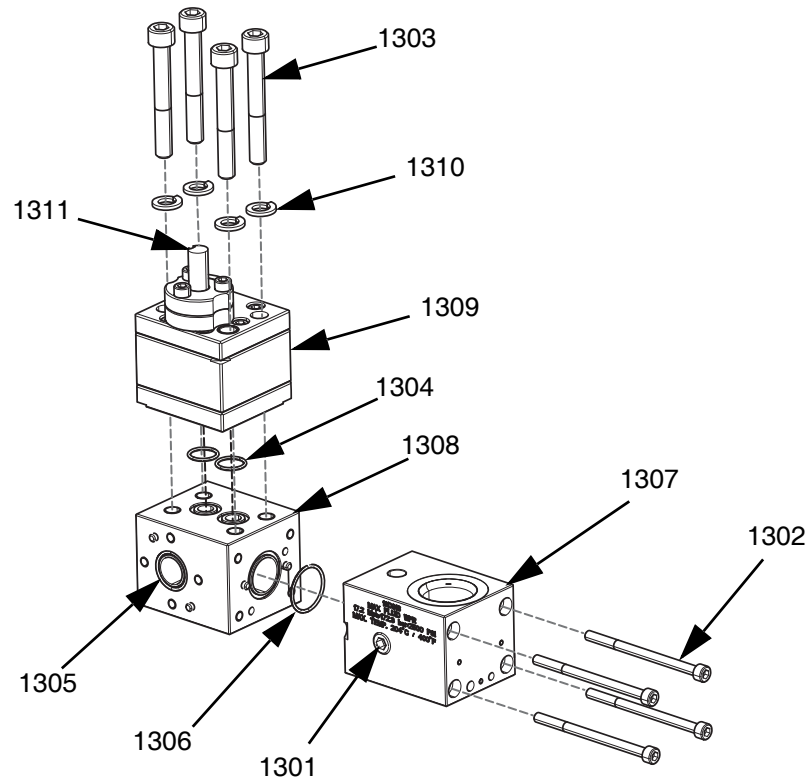

Ref	Part	Description	Qty
1301	101970	PLUG, pipe, headless	2
1302	124173	SCREW, shcs, M6-1.0 x 90, stainless steel	4
1303	124174	SCREW, shcs, M10- 1.5 x 75, stainless steel	4
1304†	---	PACKING, o-ring	2
1305†	---	O-RING	1
1306†	---	PACKING, o-ring	1
1307	16D916	BLOCK, inlet, PGM	1
1308	16E340	BLOCK, pump mounting, PGM-6	1
1309*	24E832	METER, gear, precision, 6cc/rev	1
1310	16K738	WASHER, split, lock, M10, sst	4
1311†		DRIVE KEY	1

† Parts are available in o-ring kit 24E677, or drive key kit 25E204.

* For part breakdown and repair kits, refer to **PGM-6 Pump Repair**, page 40.

PGM-6 Pump Heat Kit

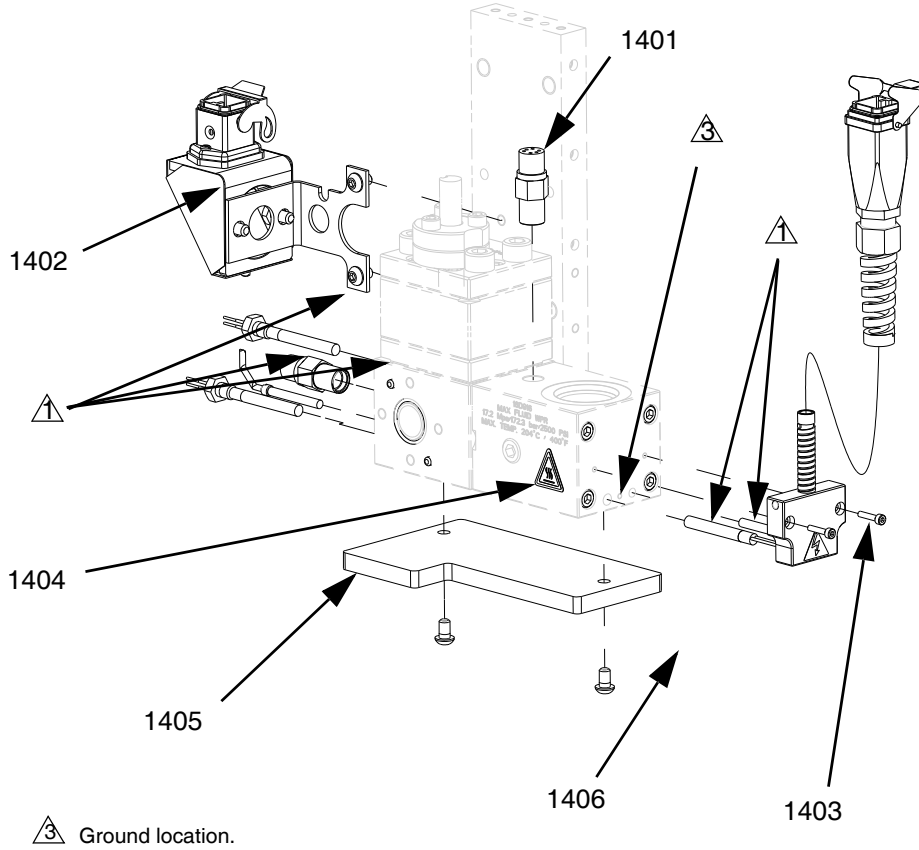

⚠ Ground location.

Ref	Part	Description	Qty
1401	117764	SENSOR, pressure	2
1402	24E732	KIT, heat, pump, PGM-6	1
1403	24E413	KIT, heat, PGM, inlet	1
1404▲	125363	LABEL, heat, warning	2
1405	16E366	INSULATOR	1
1406	124166	SCREW	2

▲ Replacement Danger and Warning labels, tags, and cards are available at no cost.

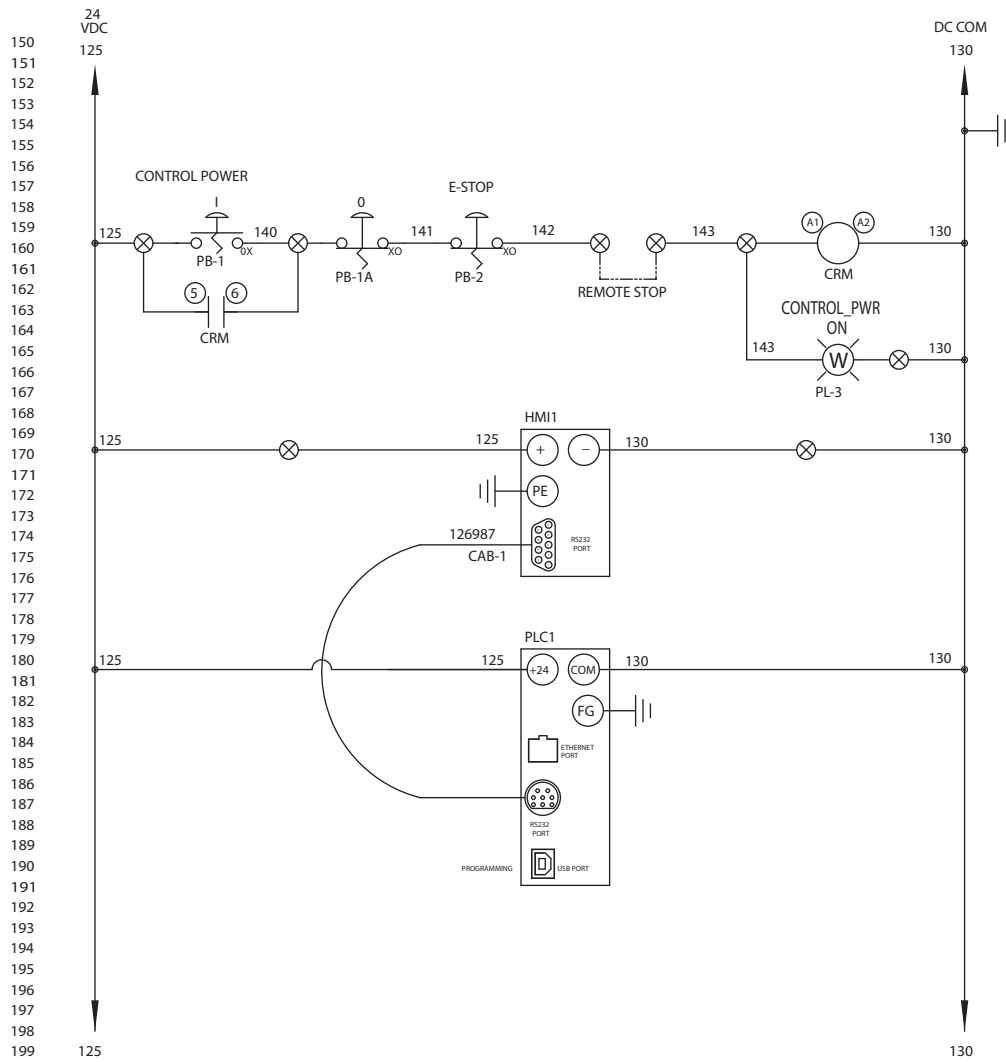

FIG. 30: Schematics, Page 2 of 10

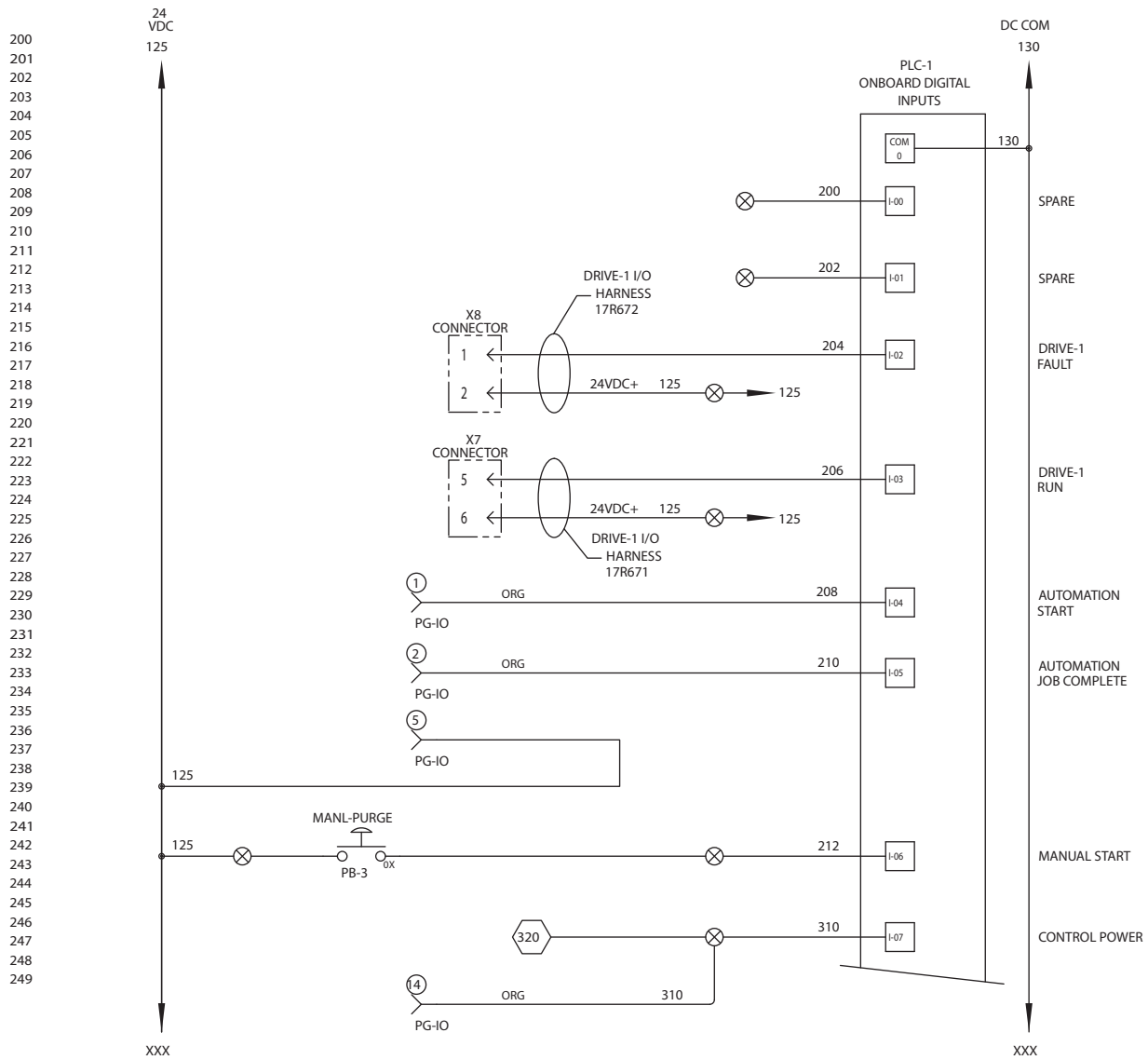
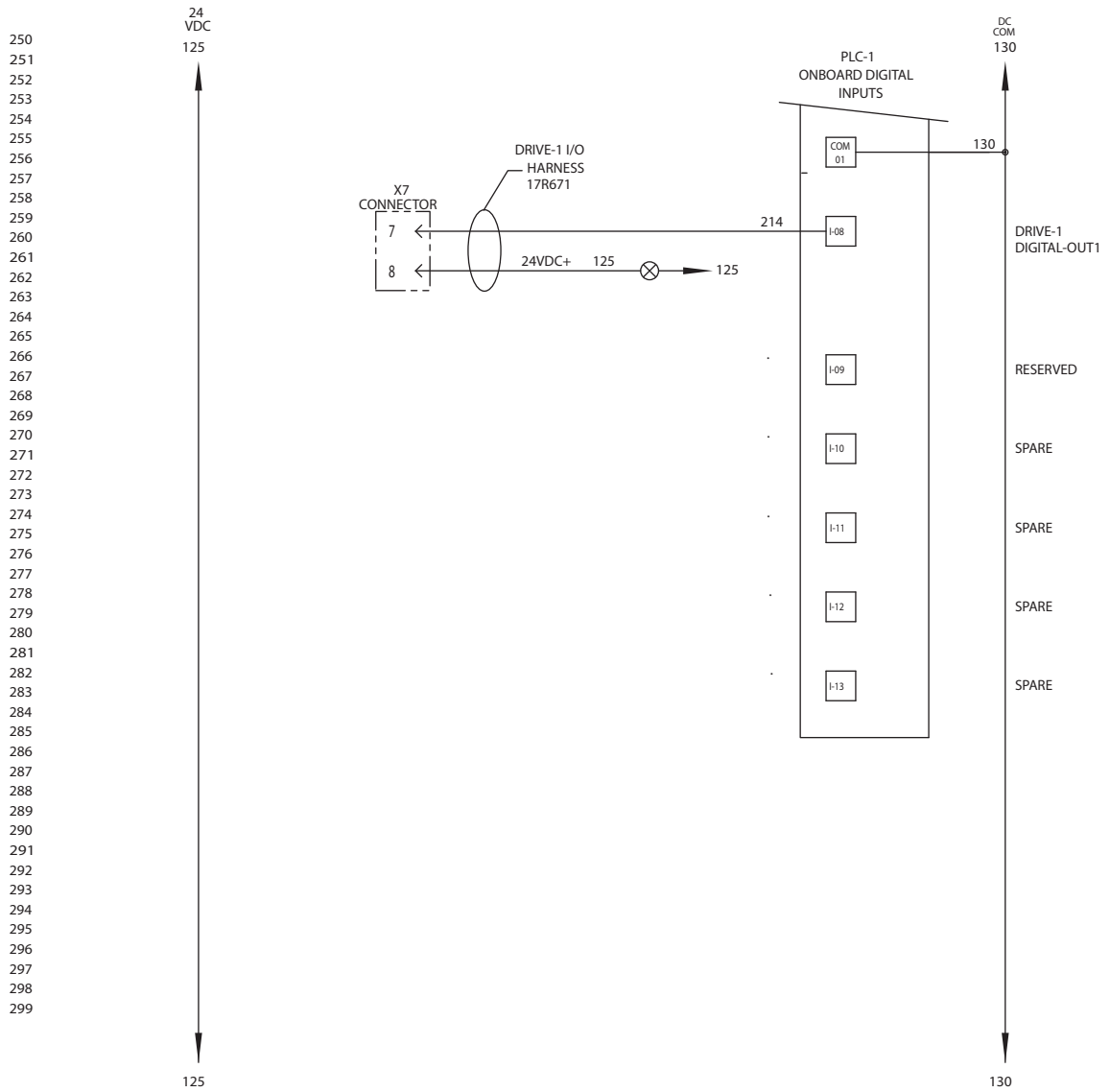

FIG. 31: Schematics, Page 3 of 10



250
251
252
253
254
255
256
257
258
259
260
261
262
263
264
265
266
267
268
269
270
271
272
273
274
275
276
277
278
279
280
281
282
283
284
285
286
287
288
289
290
291
292
293
294
295
296
297
298
299

FIG. 32: Schematics, Page 4 of 10

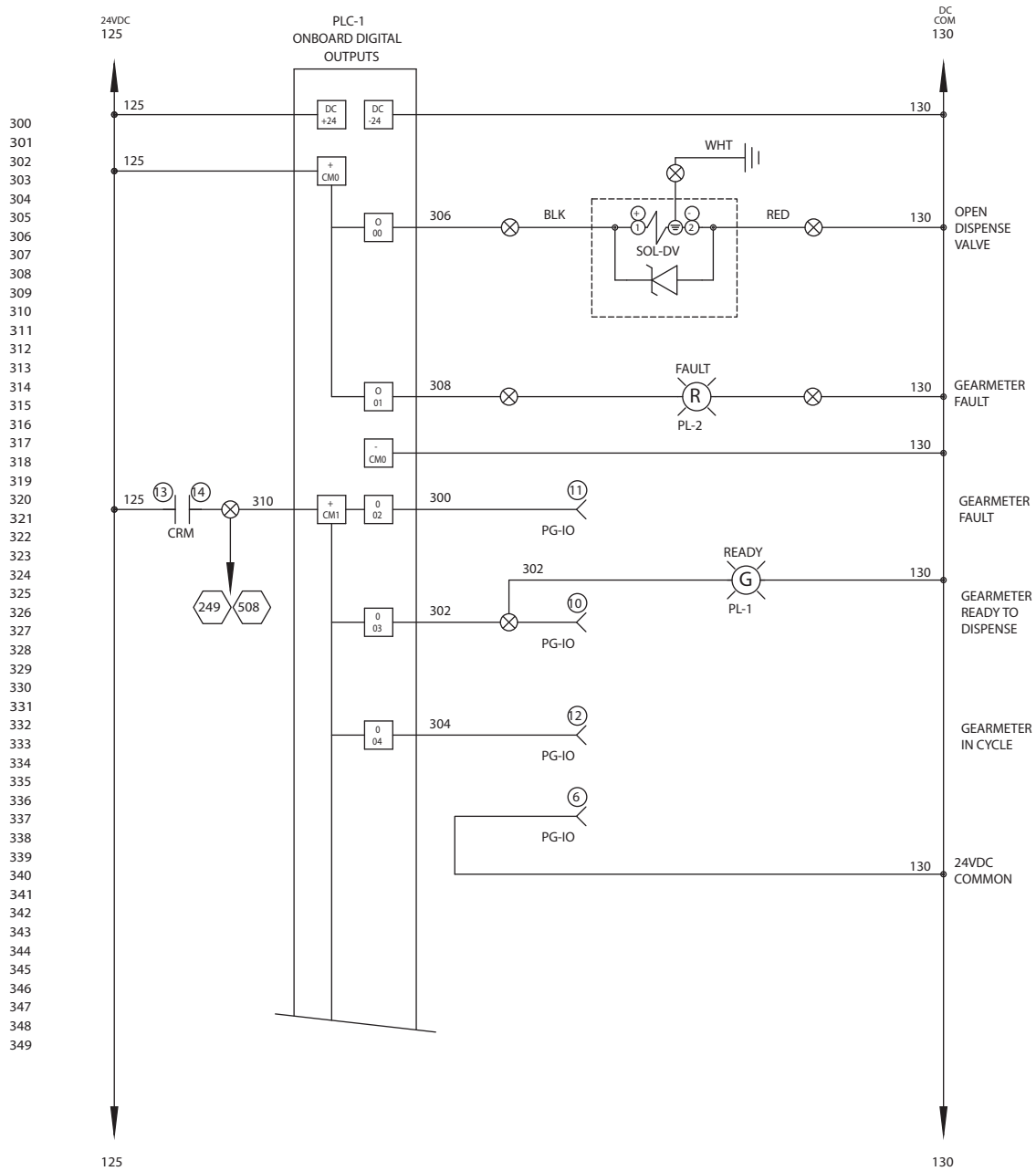

FIG. 33: Schematics, Page 5 of 10

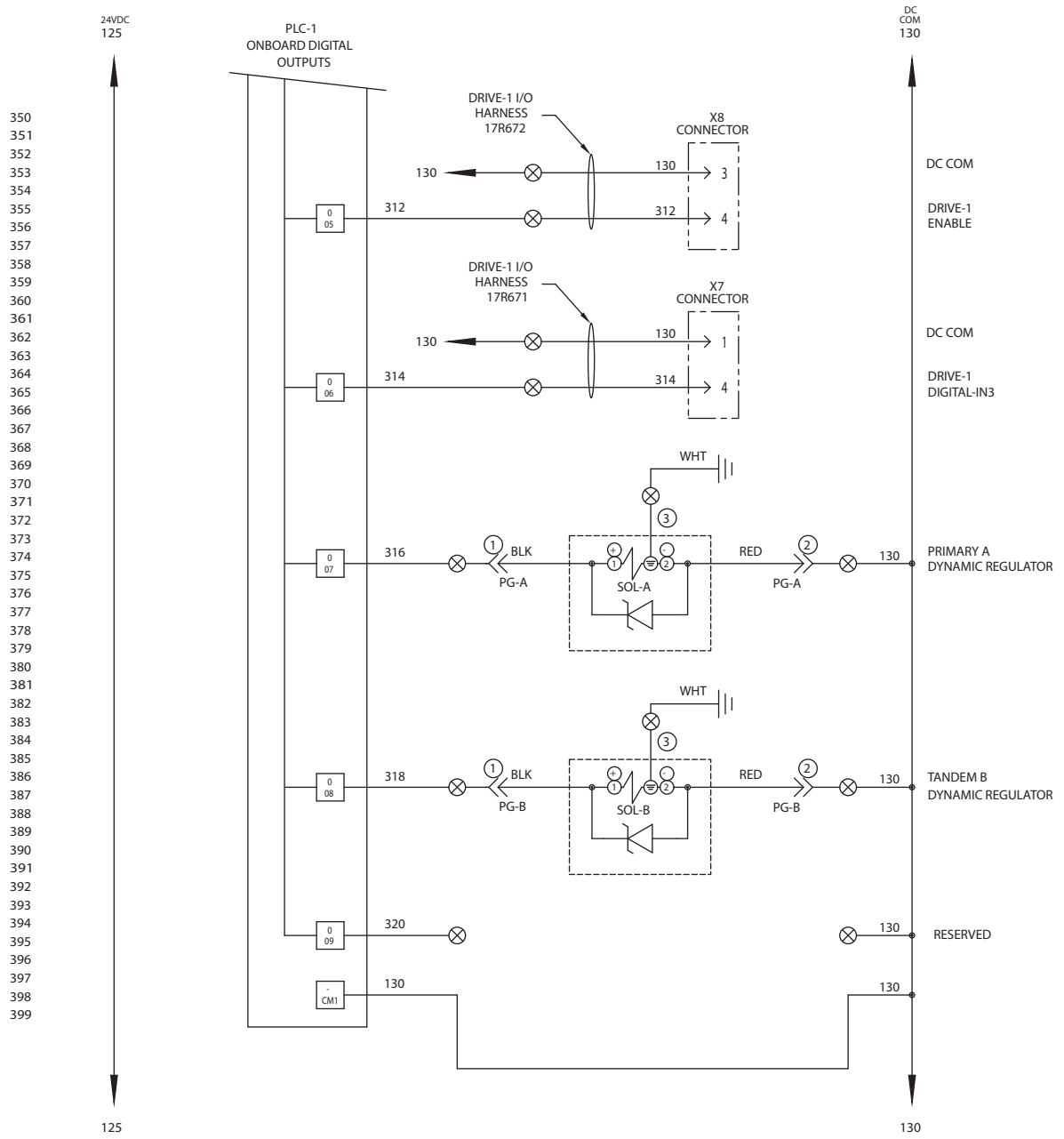

FIG. 34: Schematics, Page 6 of 10

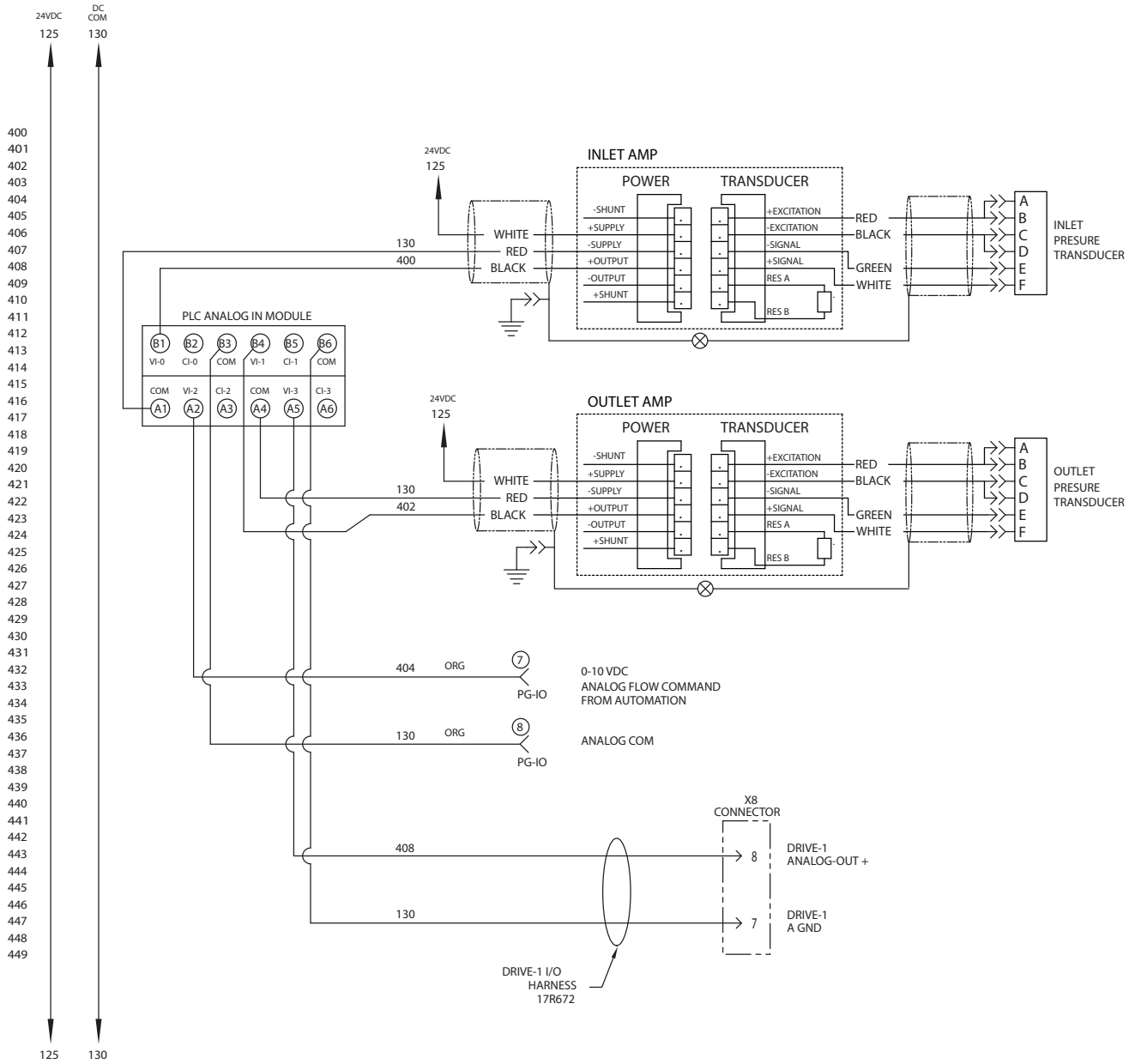

Fig. 35: Schematics, Page 7 of 10

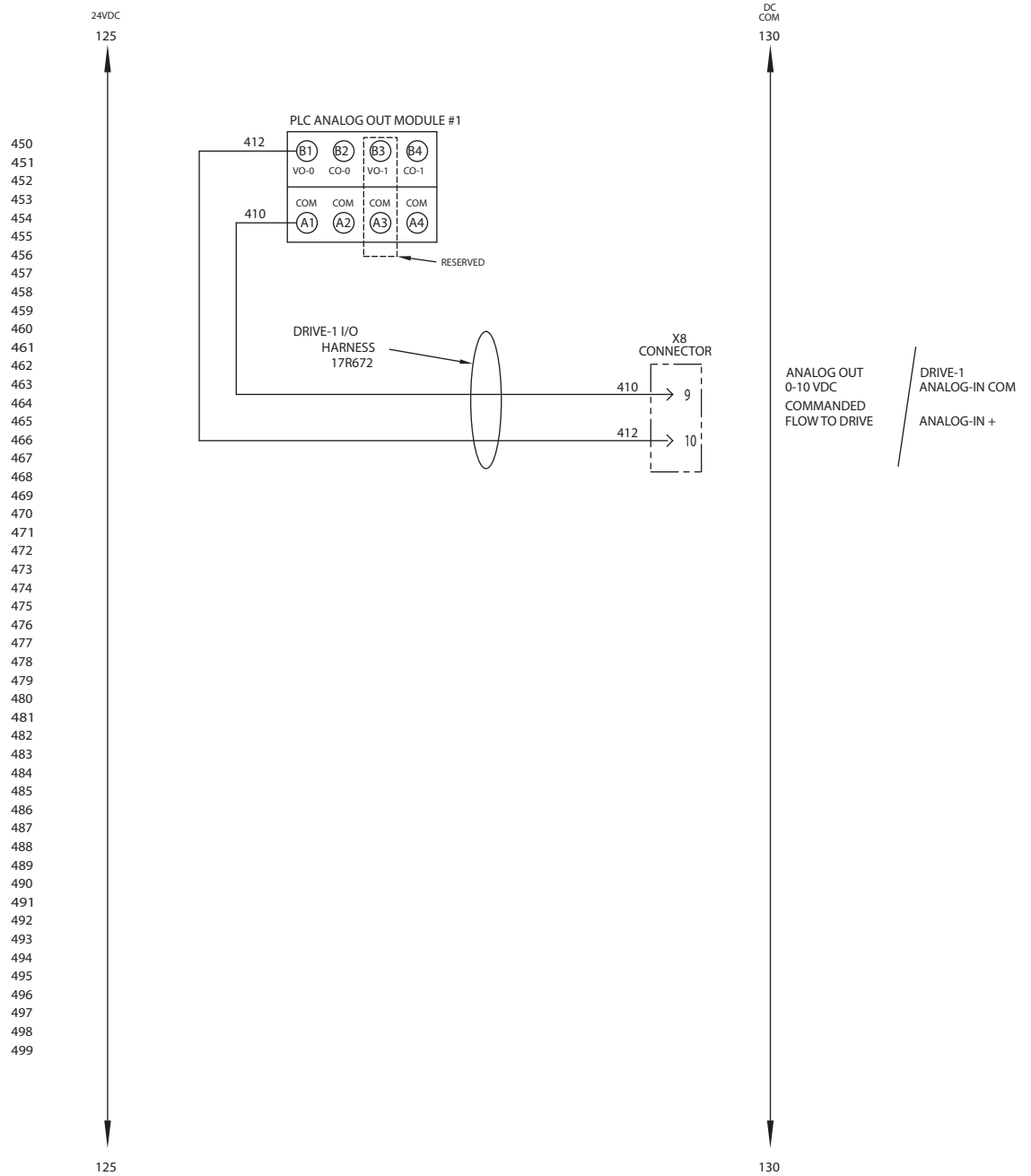

FIG. 36: Schematics, Page 8 of 10

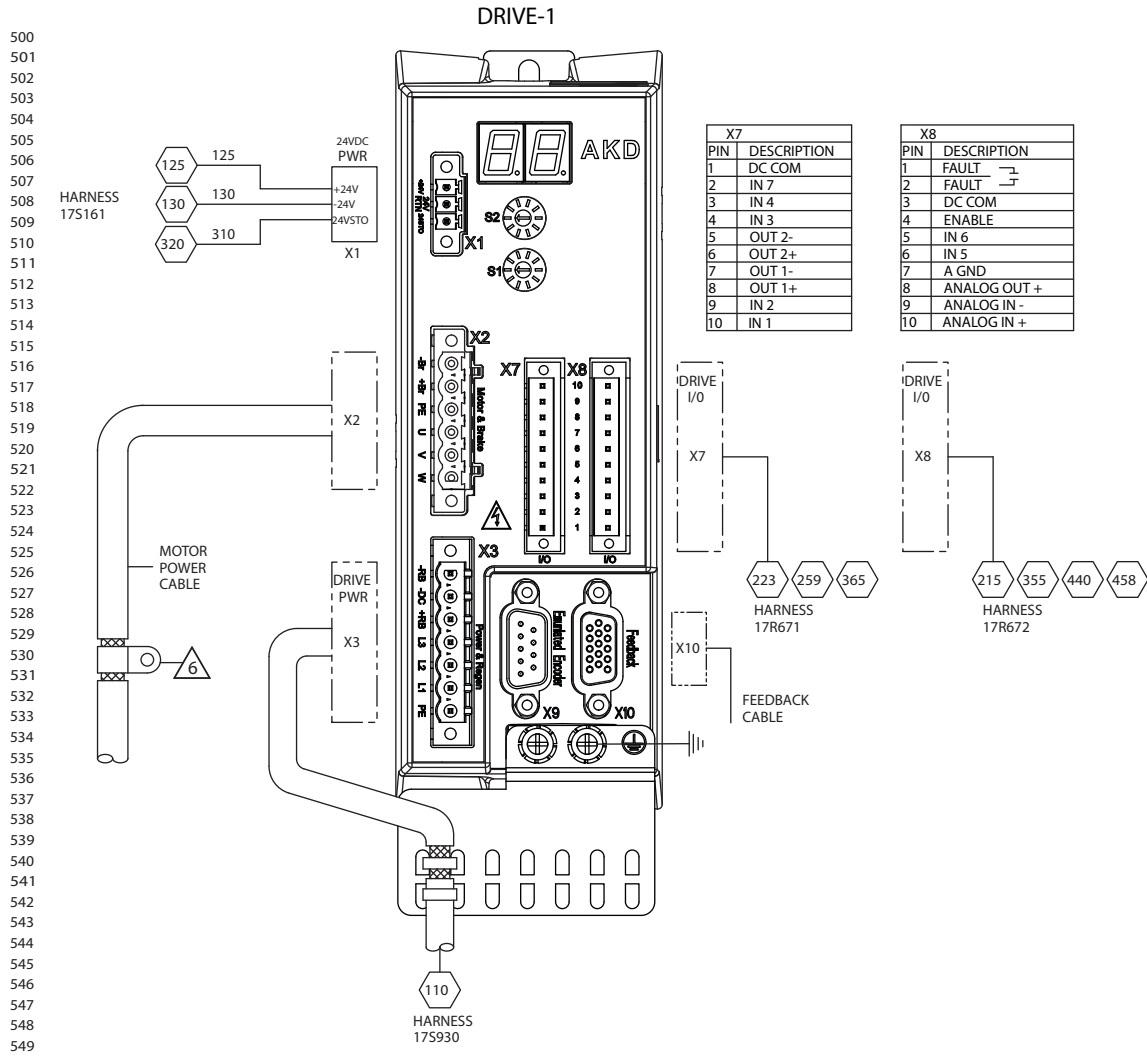

Fig. 37: Schematics, Page 9 of 10

550
551
552
553
554
555
556
557
558
559
560
561
562
563
564
565
566
567
568
569
570
571
572
573
574
575
576
577
578
579
580
581
582
583
584
585
586
587
588
589
590
591
592
593
594
595
596
597
598
599

- GROUNDING NOTES:
1. GROUND ALL DISTRIBUTION BARS.
2. GROUND ALL DOORS.
3. DO NOT JUMPER GROUND WIRES.

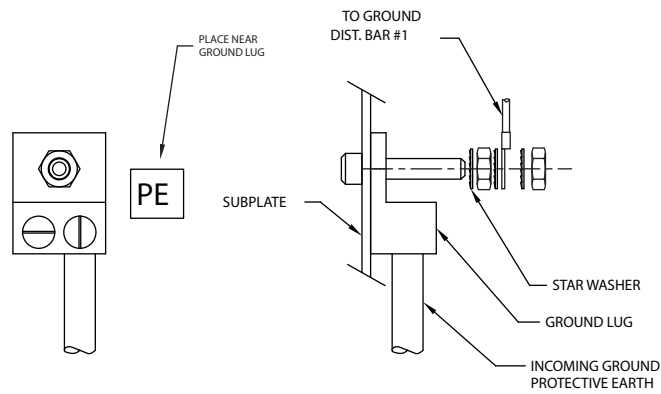

FIGURE 1
NTS



FIGURE 2
NTS

FIG. 38: Schematics, Page 10 of 10

Accessory Parts

Automation Interface Cable Assembly

The cable length of automation interface cable assembly 24D824 is 40 ft (12.2 m). This figure shows the cable and identifies the cable interface signals. See **Appendix B - I/O** on page 98 for wiring details. See **Appendix C - Theory of Operation** on page 101.

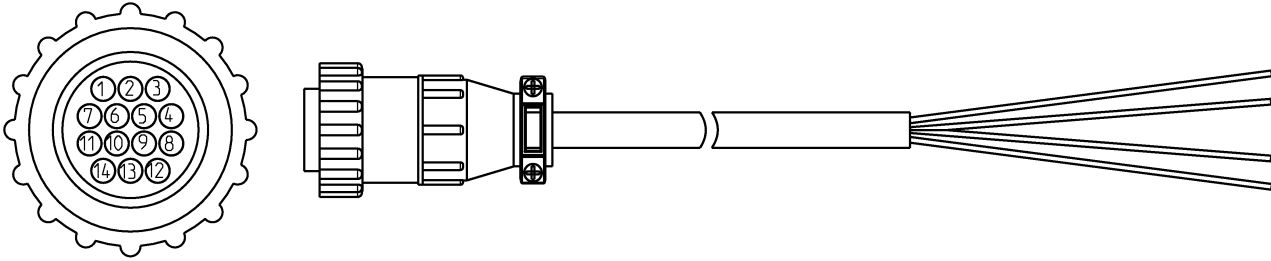

Pin #	Wire #	Color	Description
1	208	Black	Dispense Start
2	210	Red	Job Complete
3	SPARE	White	N/C
4	SPARE	White/Black	N/C
5	125	Orange	24 VDC from PGM
6	130	Blue	24 VDC common
7	404	Red/Black	Analog flow command
8	130	Green	Analog common
9	SPARE	Green/Black	N/C
10	302	Blue/Black	Dispenser ready
11	300	Red/White	Fault present
12	304	Orange/Black	In cycle
13	SPARE	Green/White	N/C
14	310	Blue/White	24 VDC thru E-stop

Dynamic Regulators (98****)

Kit 24E575

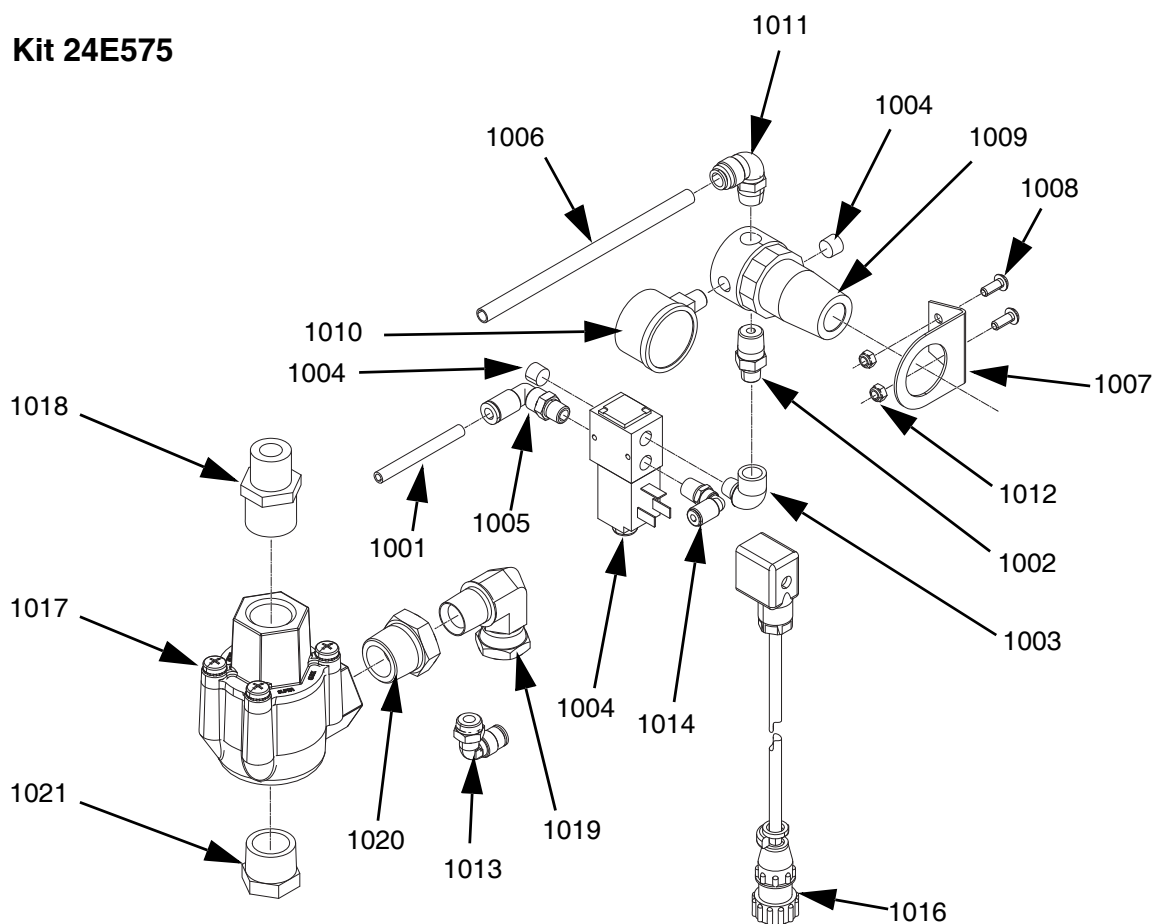

NOTE: This kit is intended for Therm-O-Flow units built prior to 2016, which includes part numbers that start with 98xxxx. See **Accessories** on page 5 for the latest version of the Therm-O-Flow which includes part number UHxxxx.

Ref	Part	Description	Qty
1001	112699	TUBE, 1/4 OD	2
1002	C20466	FITTING, nipple, hex	1
1003	112307	FITTING, elbow, street	1
1004	100139	PLUG, pipe	2
1005	112781	FITTING, elbow, swivel	1
1006	054776	TUBE, nylon, round, 5/16 in/ 8 mm	2
1007	110321	BRACKET, mounting	1
1008	297612	SCREW, cap, button head	2
1009	110318	REGULATOR, air, 1/4 in. npt	1
1010	110319	GAUGE, pressure, air, 1/8 npt	1
1011	115948	FITTING, elbow, 1/4 nptM, 5/16T OD	1
1012	107110	NUT, lock	2
1013	121022	FITTING, elbow, male, 1/4 npt	1
1014	198171	FITTING, elbow	1
1015	198446	VALVE, dispense, closer	1
1016	24E574	CABLE, feed regulator, PGM, 9 meter	1
1017	080226	VALVE, quick exhaust, 3/4 in. nptf	1
1018	C20461	FITTING, nipple, reducing, hex	1
1019	125466	FITTING, swivel, elbow, 1/2 nptf	1
1020	100896	FITTING, bushing, pipe	1
1021	111530	MUFFLER	1

Dynamic Regulator Setup and Installation (P/N 98****) 24E575



1. Remove air pressure from Therm-O-Flow supply system. See Pressure Relief Procedure in manual 311208.
2. Install dynamic regulator kit. See FIG. 39 on page 77.
3. Apply air to the Therm-O-Flow supply. Check for air leaks.
4. Set the secondary regulator for a low operating pressure, for example 20-25 psi.
5. Adjust the panel mount Therm-O-Flow regulator to zero psi.
6. Connect the dynamic regulator cable from the Therm-O-Flow to the PGM control box.
7. Navigate to the Supply Pump screen. See **Appendix A - User Interface Display** starting on page 82 for Supply Pump screen information.
8. Select ON mode for the Primary or Tandem Pump drop-down menu.
9. Set the appropriate press for the panel mount regulator on the Therm-O-Flow. For example, 30-40 psi.
10. Select AUTO mode for the Primary or Tandem Pump drop-down menu.
11. Verify operation of the new regulator and adjust pressure as needed to achieve a maximum static pressure of 1500 psi (103 bar) when the system is not dispensing.

Dynamic Regulator Installation 24E575

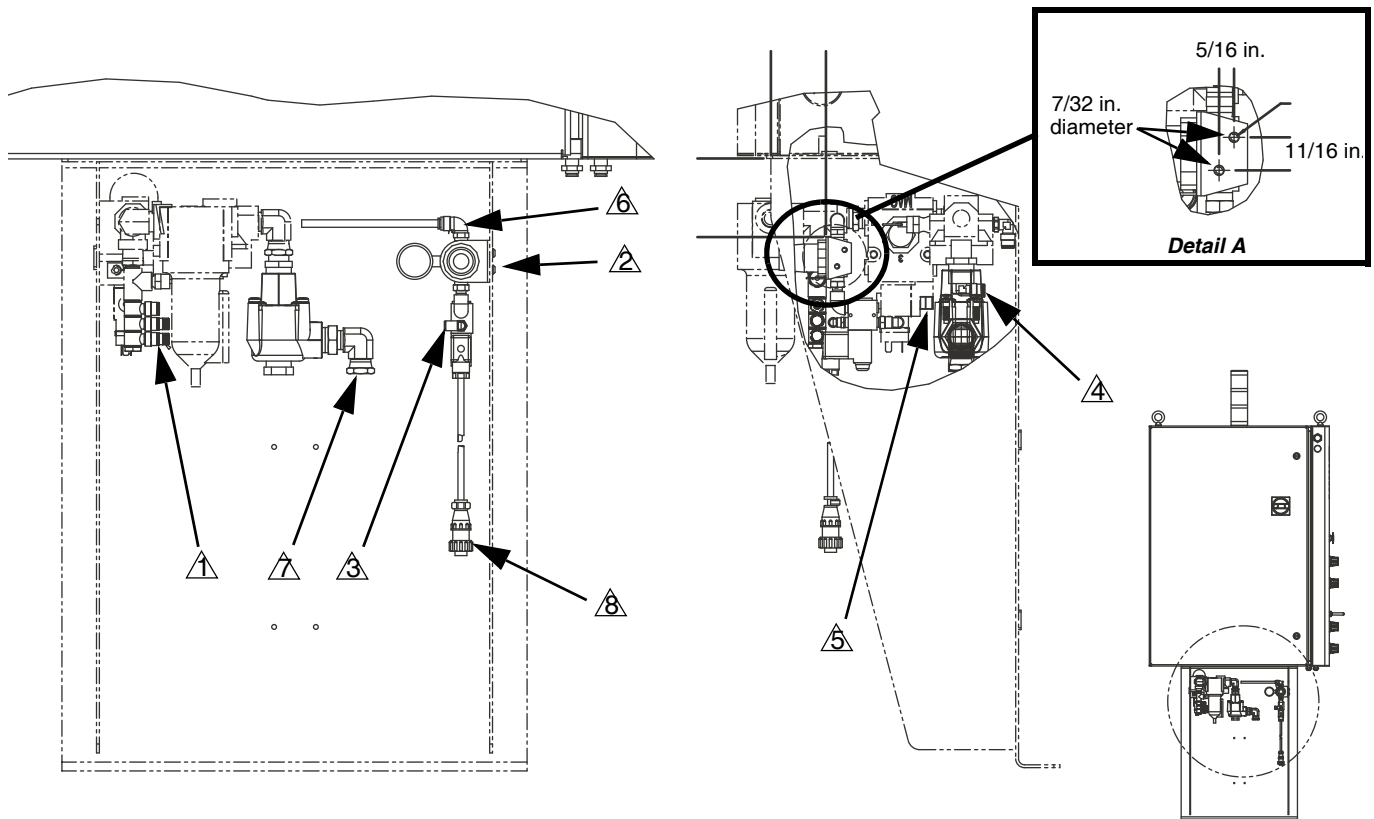

- ① Remove plug and attach supplied tubing to regulator inlet.
- ② Holes required for mounting. See detail A.
- ③ 5/32 in. tubing removed from Therm-O-Flow regulator to be attached here.
- ④ Regulator pilot port will have an existing 5/32 in. air line. This air line and its fitting are to be removed from the regulator and replaced with the fitting supplied with dynamic regulator. The existing pilot tube will be connected to the 5/32 fitting on the diverting valve supplied with 24E575.
- ⑤ To Therm-O-Flow regulator pilot port.
- ⑥ Regulator inlet.
- ⑦ Thread existing air line with 1/2 in. npt coupling to 90° swivel fitting.
- ⑧ Attach to PGM control panel.

FIG. 39

The dynamic regulator kit is used to control the static pressure of a Therm-O-Flow (98****). The PGM has a maximum inlet pressure of 1500 psi. During dispense the dynamic regulator kit will activate the normal regulator located on the front panel of the Therm-O-Flow. When the system is idle the secondary regulator will control static pressure.

Dynamic Regulators (UH****)

Kit 25A055

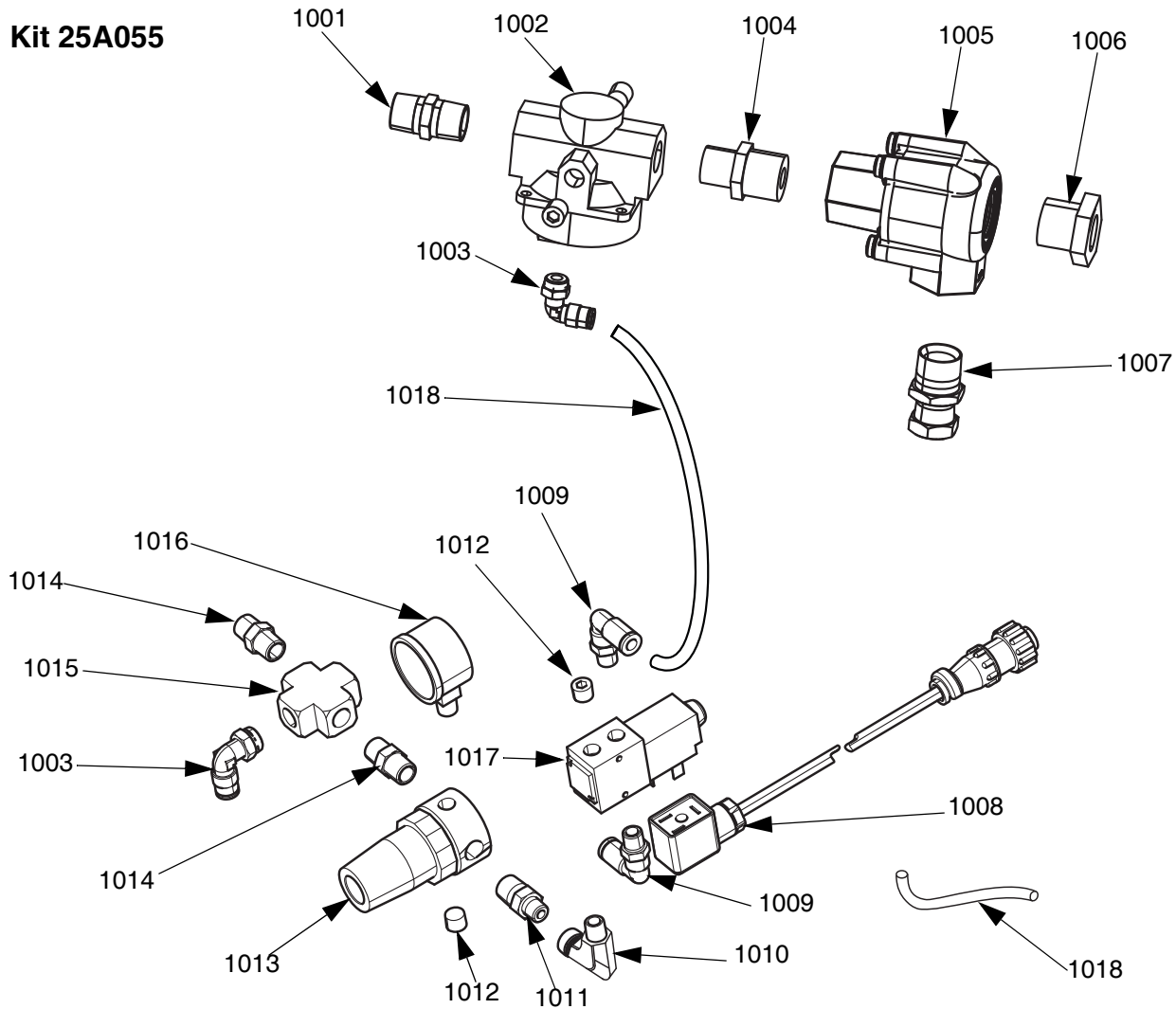

NOTE: This kit is for the current series of Therm-O-Flow which contains part number UHxxxx.

Ref	Part	Description	Qty
1001	158491	FITTING, nipple	1
1002	120435	REGULATOR, remote piloted	1
1003	121022	FITTING, elbow, male, 1/4 npt	2
1004	C20461	FITTING, nipple, reducing, hex	1
1005	080226	VALVE, quick exhaust, 3/4" nptf	1
1006	111530	MUFFLER	1
1007	121282	FITTING, swivel, straight, 1/2 fx3/4 m	1
1008	24E574	CABLE, feed regulator, pgm, 9 mtr	1
1009	112781	ELBOW, swivel, 90 deg	2
1010	112307	FITTING, street elbow	1
1011	C20466	FITTING, nipple, hex	1
1012	100139	PLUG, pipe	2
1013	110318	REGULATOR, air, 1/4" npt	1
1014	123257	FITTING, nipple, hex, 1/4 npt, brs	2
1015	113264	CROSS, pipe	1
1016	110319	GUAGE, press, air, 1/8" npt	1
1017	198446	VALVE, dispense, closer	1
1018	054130	TUBE, plyeth .250 od	3

Dynamic Regulator Setup and Installation (P/N UH****) 25A055



1. Remove air pressure from Therm-O-Flow supply system. See Pressure Relief Procedure in manual 334130.
2. Install dynamic regulator kit. See FIG. 40 on page 80.
3. Apply air to the Therm-O-Flow supply. Check for air leaks.
4. Set the secondary regulator for a low operating pressure, for example 20-25 psi.
5. Adjust the air motor regulator at the top of the air tree to zero psi.
6. Connect the dynamic regulator cable from the Therm-O-Flow to the PGM control box.
7. Navigate to the Supply Pump screen. See **Appendix A - User Interface Display** starting on page 82 for Supply Pump screen information.
8. Select ON mode for the Primary or Tandem Pump drop-down menu.
9. Set the appropriate pressure for the air motor regulator at the top of the air tree on the Therm-O-Flow. For example, 30-40 psi.
10. Select AUTO mode for the Primary or Tandem Pump drop-down menu.
11. Verify operation of the new regulator and adjust pressure as needed to achieve a maximum static pressure of 1500 psi (103 bar) when the system is not dispensing.

Dynamic Regulator Installation

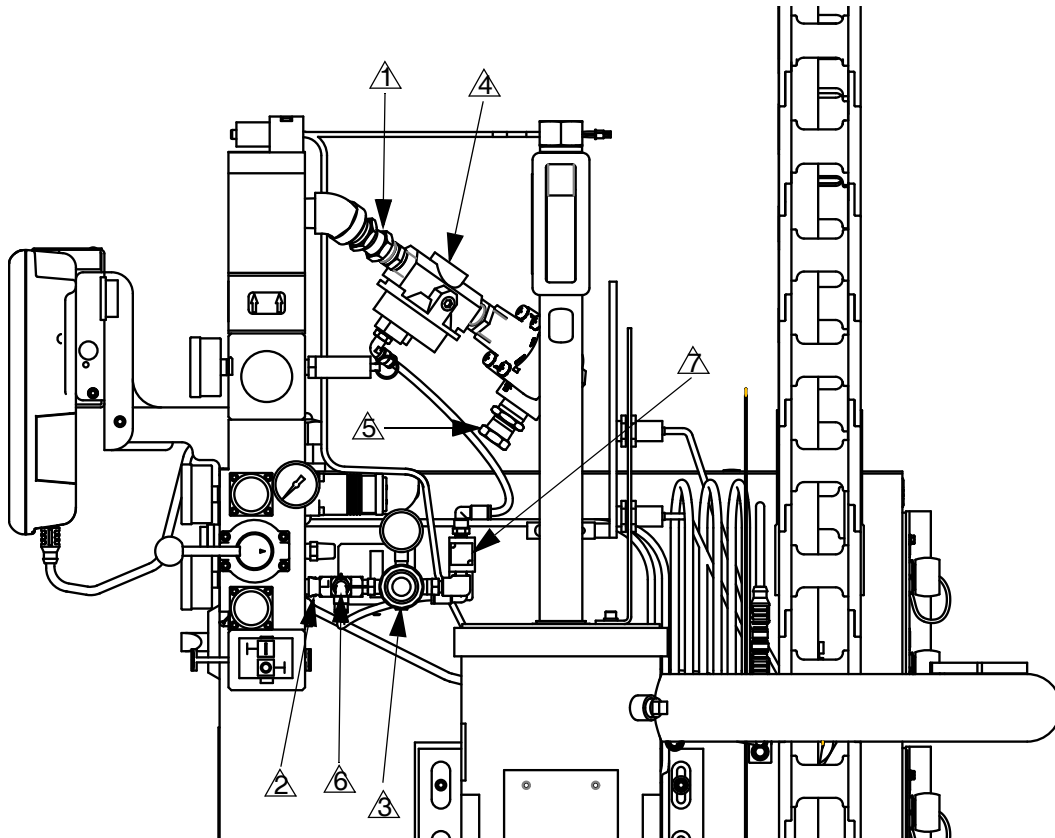

- | | |
|--|---|
| <p>1 Disconnect red airline from air tree.</p> <p>2 Remove pressure relief safety valve from air tree.</p> <p>3 Screw in the cross with adjustable air pressure regulator into the pressure relief safety valve hole.</p> <p>4 Attach the dynamic regulator assembly to the hose connection on the air tree.</p> | <p>5 Attach the red air hose to the dynamic regulator assembly.</p> <p>6 Attach the pressure relief safety valve to open port on the cross fitting.</p> <p>7 Attach to PGM control panel.</p> |
|--|---|

FIG. 40

The dynamic regulator kit is used to control the static pressure of a Therm-O-Flow (UH****). The PGM has a maximum inlet pressure of 1500 psi. During dispense the dynamic regulator kit will activate the normal regulator located on the front panel of the Therm-O-Flow. When the system is idle, the secondary regulator will control static pressure.

EnDure Valve Nozzles

Part	Description
24E654	10 x 1.5 mm Ribbon Nozzle
24E655	1/8 in. Bead Nozzle

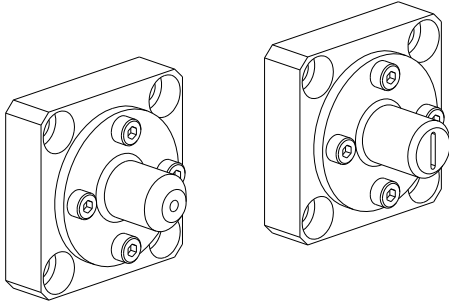

Heater Nests

Part	Description
24E678	Heater Nest with Blank Insert
24E679	Heater Nest with Ported Insert

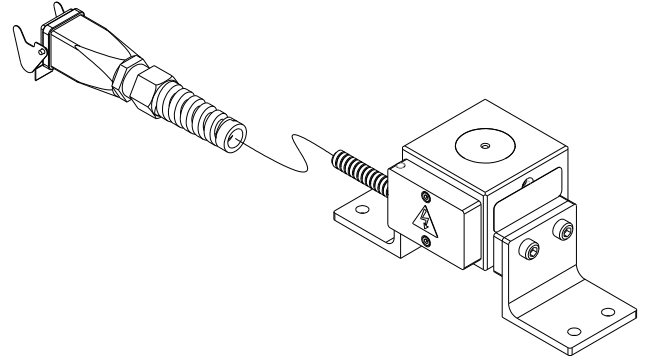

Appendix A - User Interface Display

Screen Navigation Diagram

START MACHINE

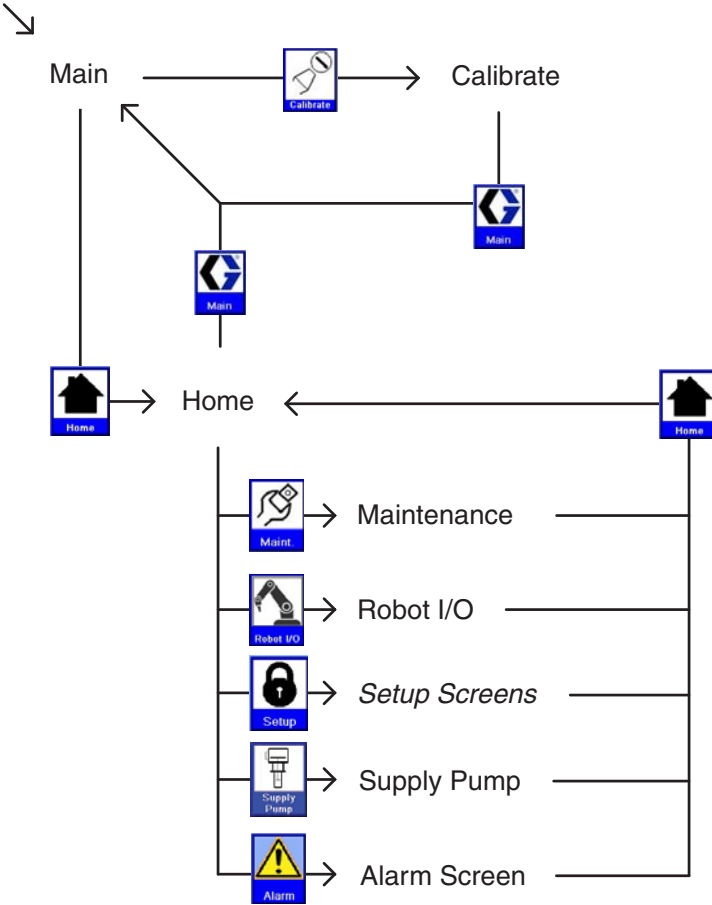

Setup Screens Flow

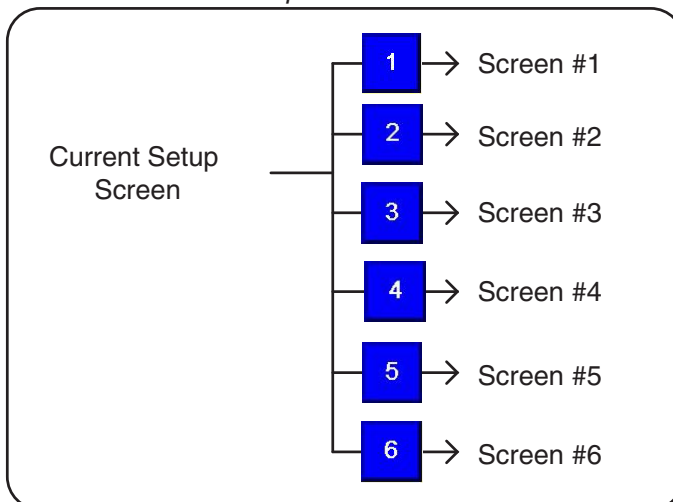

Main Screen

Press the appropriate button to navigate to either the Home or Calibration screen. To access the Calibration screen, select the login button and enter user "setup" and password "PGM17".

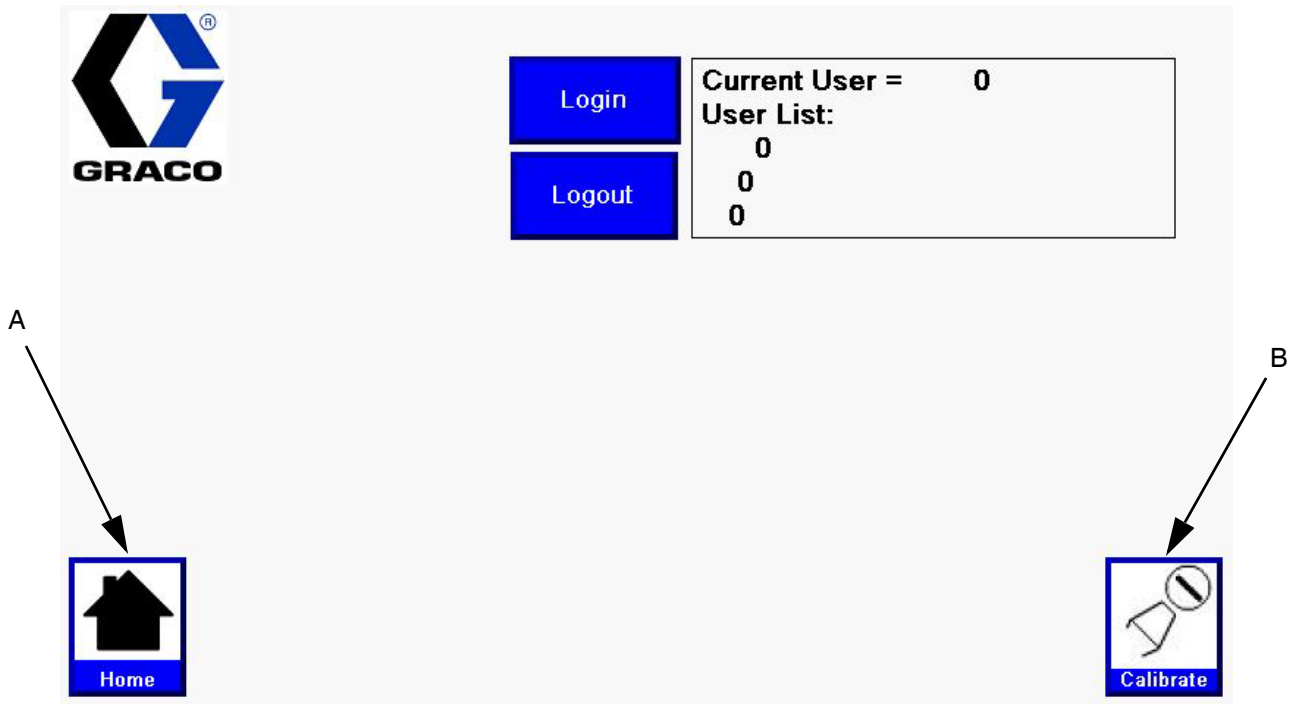

Key:

- A Navigate to the Home screen
- B Navigate to the Calibrate screen

Calibrate Screen

NOTE: See Calibration procedure on page 24.

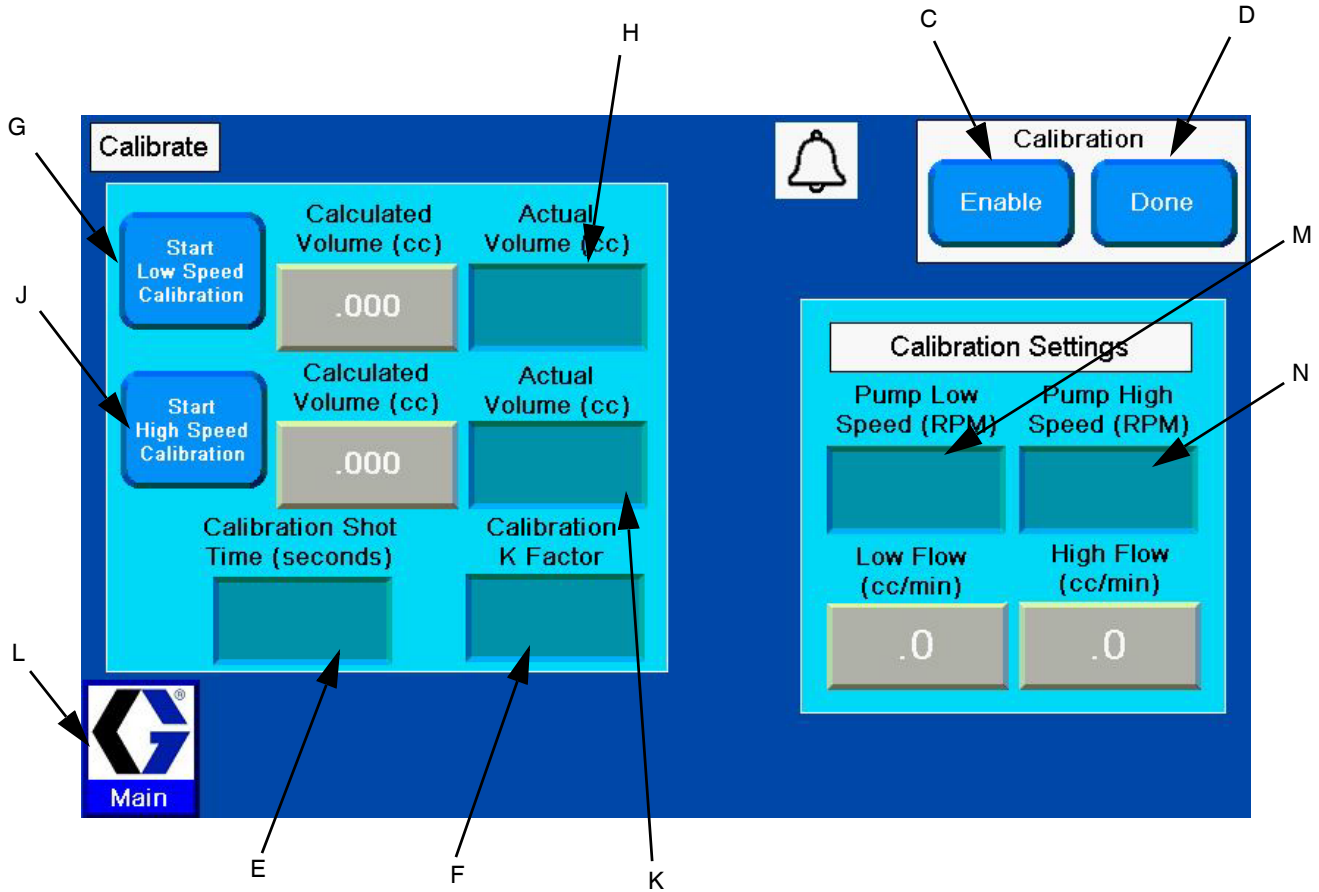

Key:

- | | |
|---|--|
| C Enable Calibration button (Begin Calibration) | H Low Speed Calibration Shot Volume Input Box |
| D Done button (Finish Calibration) | J Start High Speed Calibration button |
| E Calibration Shot Time Input Box | K High Speed Calibration Shot Volume Input Box |
| F Calibration K Factor (Automatically Calculated) | L Navigate to Main Screen |
| G Start Low Speed Calibration button | M Pump RPM during low speed calibration |
| | N Pump RPM during high speed calibration |

Home Screen

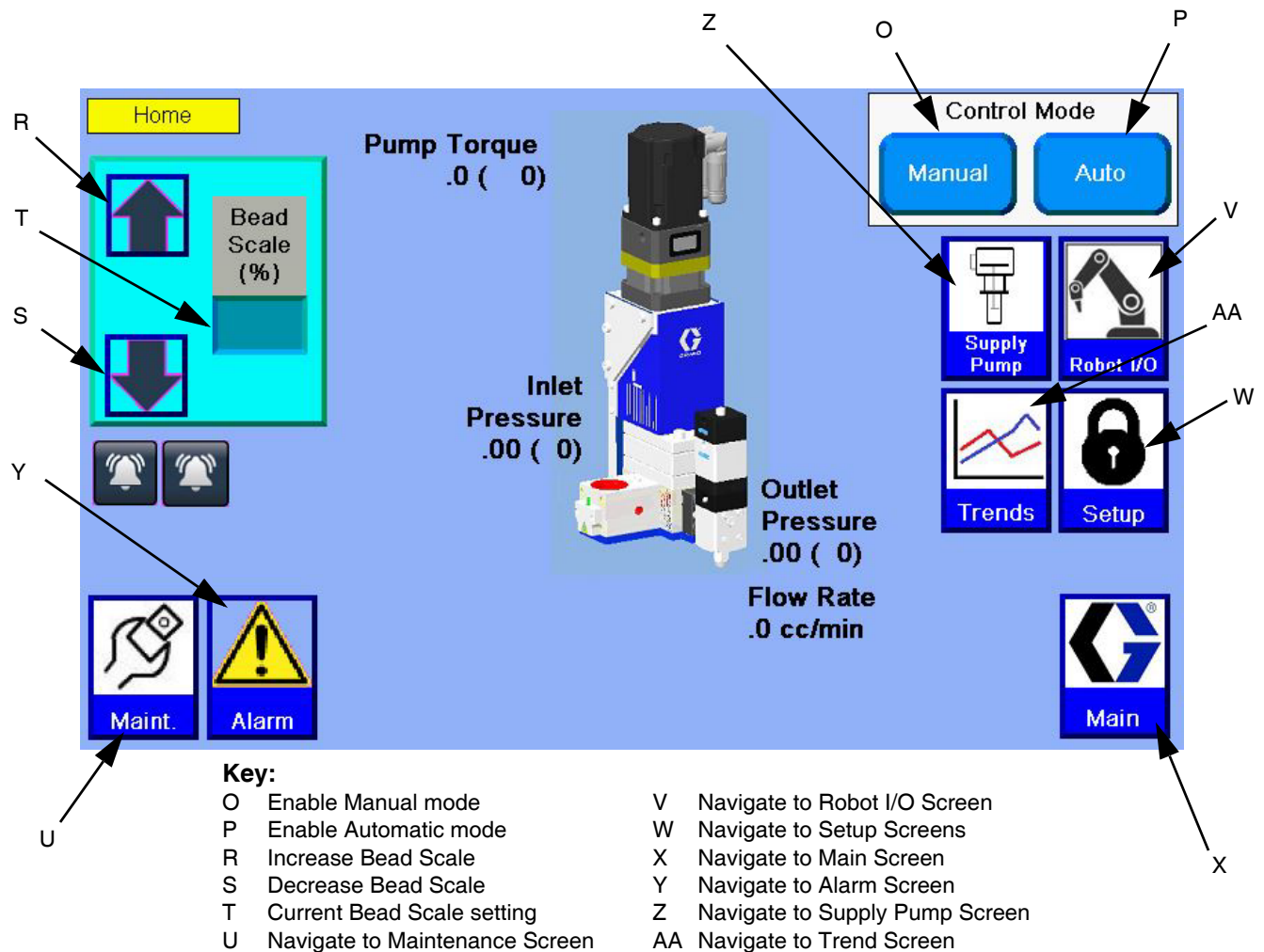

Manual Mode

In Manual Mode, the machine only accepts signals from the User Interface touch screen and the physical buttons on the machine. All signals from an External Control Interface to initiate a shot will be ignored.

Automatic Mode

In Automatic Mode, the machine only accepts initiate shot signals from an external machine. All signals to initiate a shot using the User Interface touch screen or the physical buttons on the machine will be ignored.

Bead Scale

The bead scale function adjusts the quantity dispensed by the scale percent value shown. For example, if the system is setup to dispense 100 cc/min and the bead scale setting is 110 then the machine will dispense $100 \text{ cc/min} \times 110\% \text{ scale} = 110 \text{ cc/min}$.

The primary purpose of the bead scale is to be able to quickly adjust volume dispensed to be able to find that actual desired volume. Once the correct volume is found, the flow rate should be adjusted accordingly.

Screens Navigation

Access to the Setup screens requires the setup password.

Flow Rate Display

The Home screen will display the commanded Flow Rate from 1 of 3 sources:

- 1 - Maintenance Flow Rate (see **Maintenance Screen** on page 86)
- 2 - Auto Mode Display Flow (see **Setup #2 Screen** on page 89)
- 3 - Remote 0-10 VDC Command Flow (see **Appendix B - I/O** on page 98)

Maintenance Screen

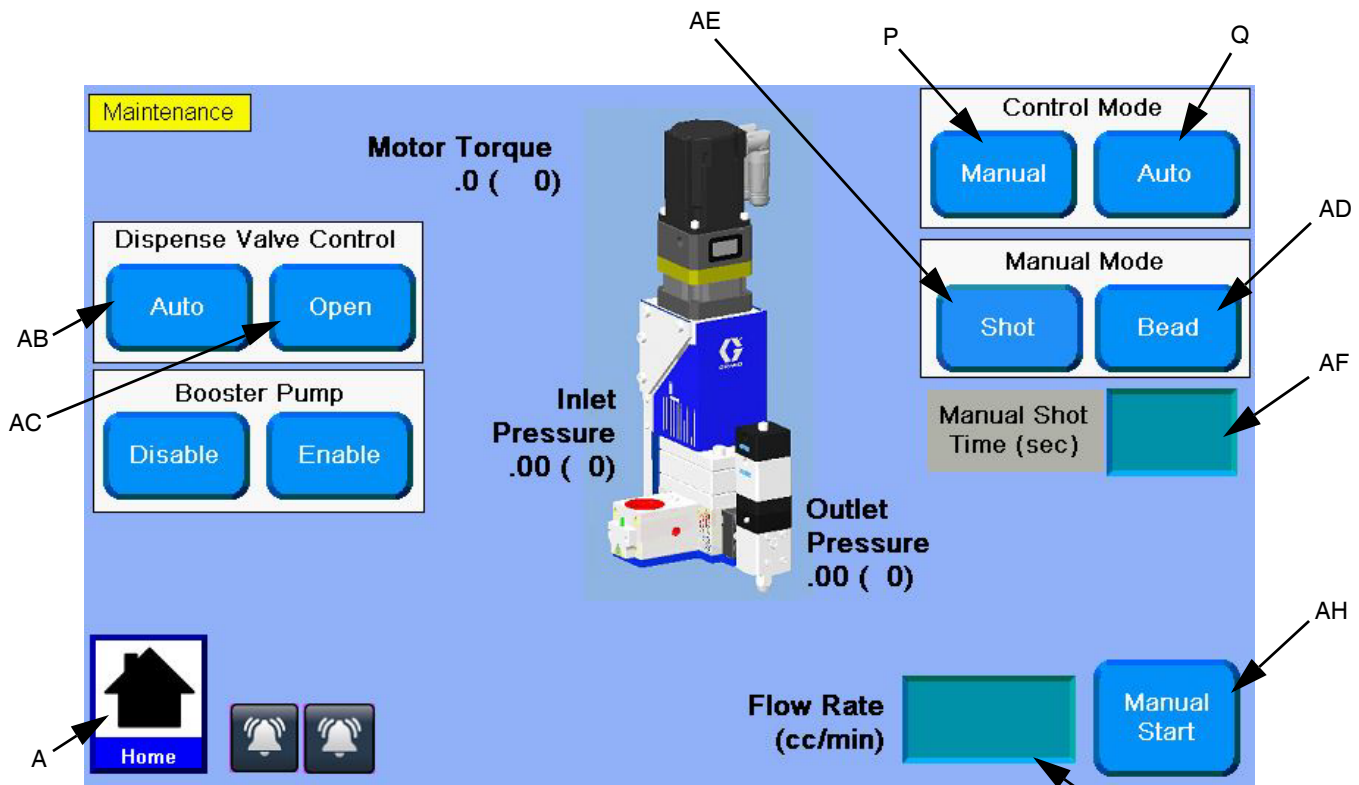

Key:

- AB Enable Automatic Dispense Valve Control
- AC Open the Dispense Valve, Disable Automatic Dispense Valve Control
- AD Enable Bead Manual Mode

- AE Enable Shot Manual Mode
- AF Dispense Duration Input Box
- AG Flow Rate Input Box
- AH Manual Start Dispense

Dispense Valve Control

When Automatic Dispense Valve Control is enabled, the dispense valve will open and close as needed to dispense material.

When Open the Dispense Valve is selected, the dispense valve will open and remain open until Automatic Dispense Valve Control is enabled.

Dispense Settings

Dispense Mode: Options include Bead and Shot.

- In Bead mode, dispensing begins when the initiate shot button is pressed and dispensing ends when the initiate shot button is released.
- In Shot mode, dispensing begins when the initiate shot button is pressed and released. Dispensing ends when the Dispense Duration (AF) elapses.

Dispense Duration: This is the amount of time the machine will dispense at the given flow rate. This value is only used in Shot Mode.

Flow Rate: This is the rate at which the machine will dispense for the given dispense duration.

Manual Start Dispense

After adjusting the settings, the user can press the Manual Start Dispense button (AH) to dispense material using the current settings.

NOTE: This button performs the same function as the manual purge button located on the control panel.

Robot I/O Screen

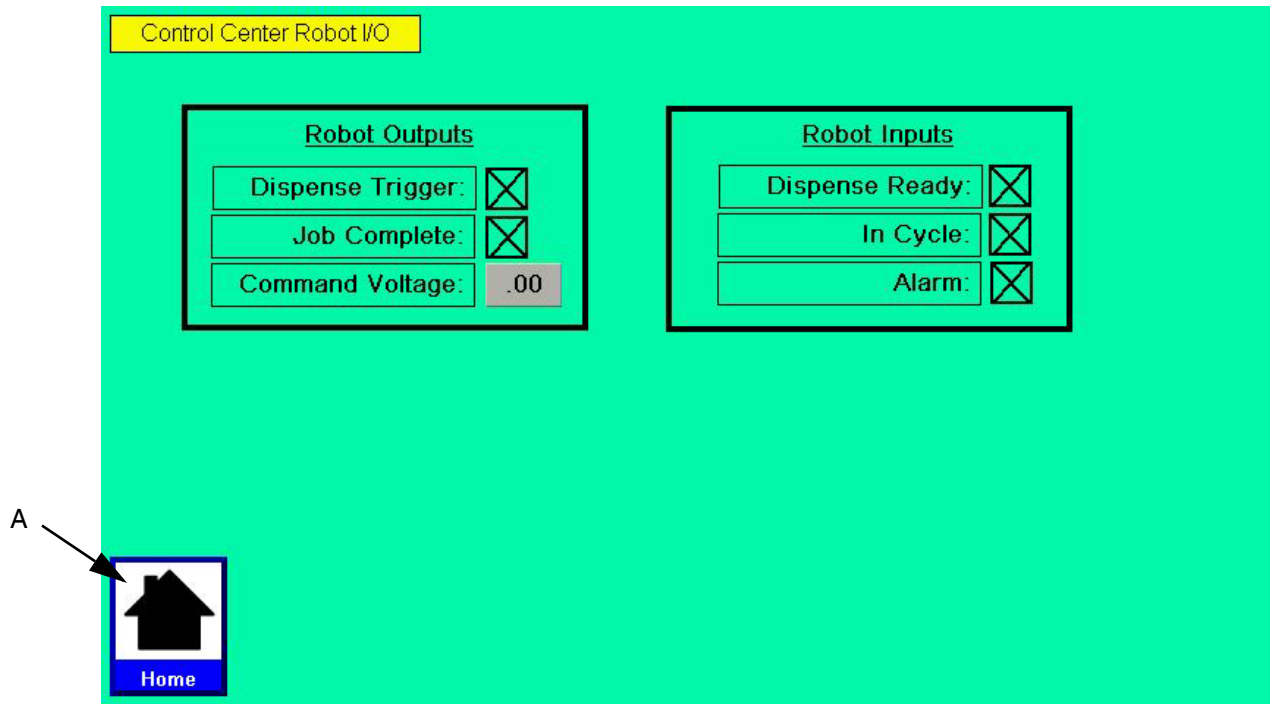

Overview

This screen is for settings related to an external machine setup to control the dispense operation of this system. See **Appendix B - I/O** on page 98 for more information.

Robot Outputs

These are signals sent by the external machine when the related action should occur. The Job Complete signal is sent to stop the In Cycle signal. The Dispense Trigger is sent to begin dispensing. The Command Voltage is a display of the voltage of the command cable and is for troubleshooting only. See **Appendix B - I/O** on page 98 for more information.

Robot Inputs

These are signals sent to the external machine to notify it of system conditions. The Dispense Ready signal tells the external machine that the system is ready to dispense and a dispense can be initiated. The No Alarm signal tells the machine that there are currently no active alarms. The In Cycle signal tells the external machine that the system is currently busy so dispensing cannot be initiated.

NOTE: Dispense Ready remains on while in Auto Mode. If a deviation alarm occurs the Dispense Ready and Alarm signal will remain ON. If an error alarm occurs the Dispense Ready will be removed.

Setup #1 Screen

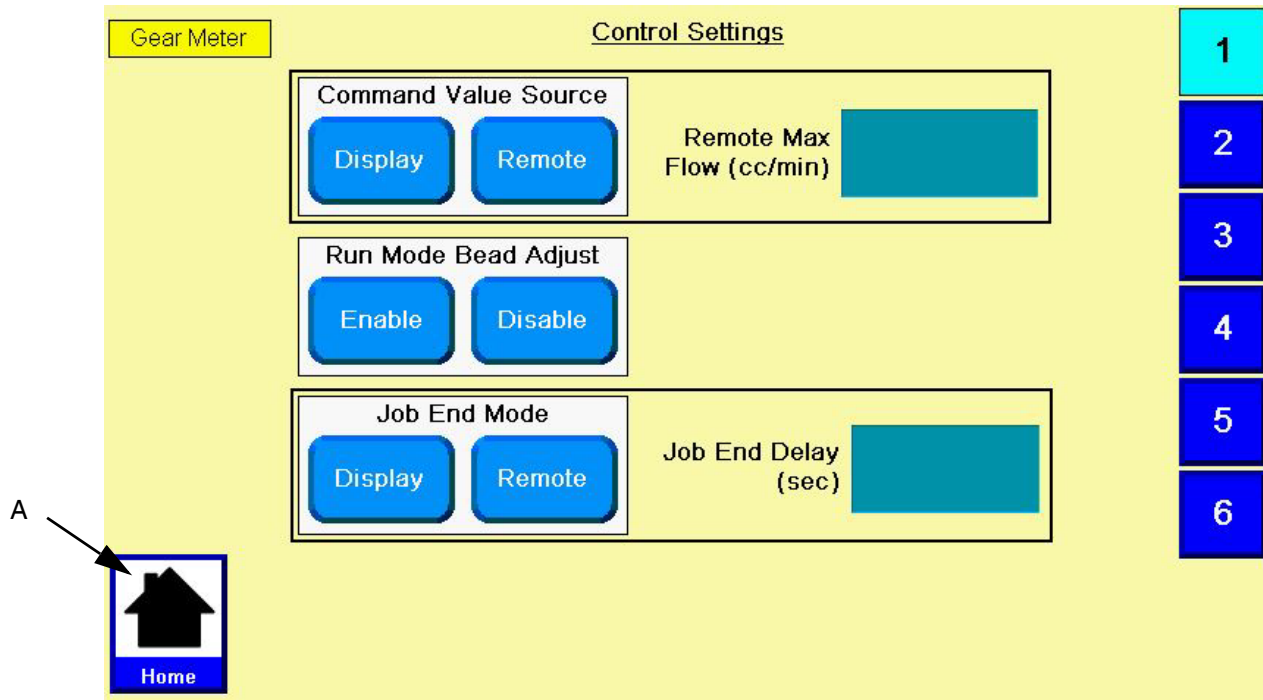

#1 to #6 Buttons

Press to navigate to the Setup Screen with that number. For example, press #3 to navigate to Setup Screen #3.

Command Value Source

Command Values can be controlled by the user-interface touch screen or by an external machine connected to the system via the External Control Interface.

Run Mode Bead Adjust

When this option is enabled the Bead Scale function appears on the Home Screen. See the **Home Screen** on page 85 for more information.

Job End Mode

The In Cycle signal can be dropped when the dispense trigger is removed when Display is selected.

If Remote is selected the Job Complete signal is required to remove the In Cycle signal.

Job End Delay (sec)

When Job End mode is set to Display the In Cycle signal is removed after the time in this field.

Setup #2 Screen

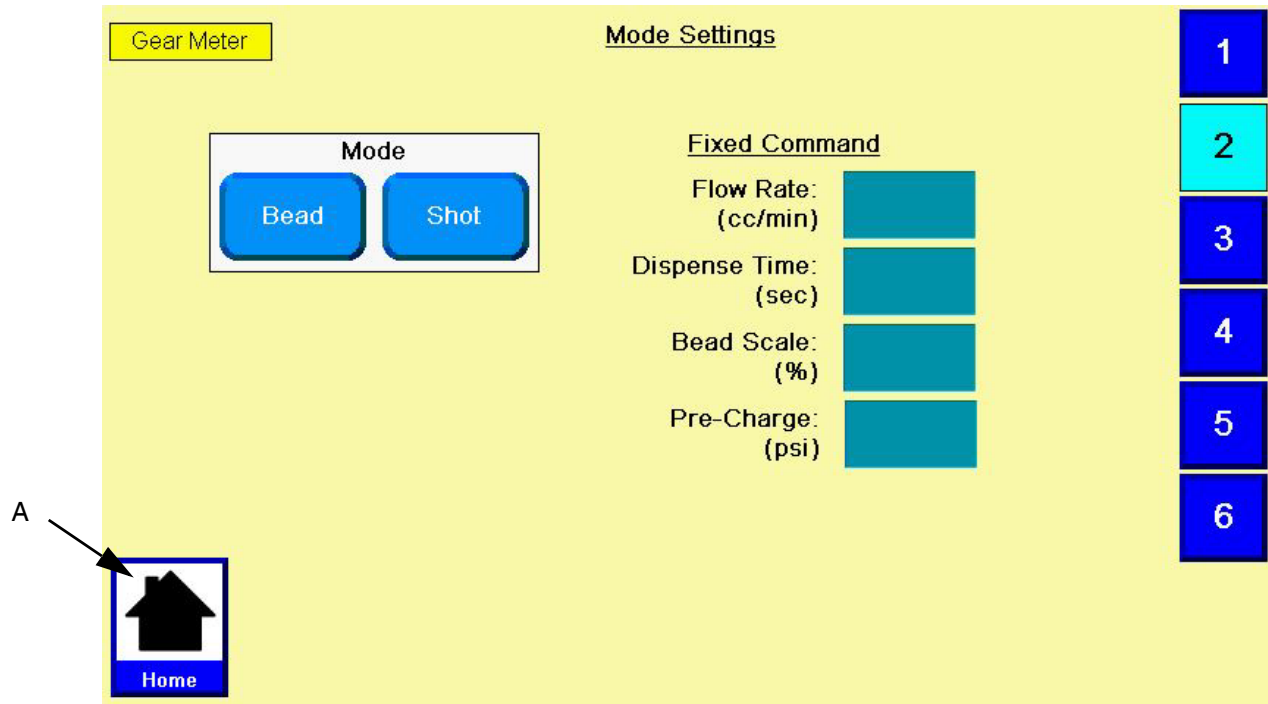

Overview

The Dispense Mode, Flow Rate, and Dispense Duration settings apply to Automatic Control Mode

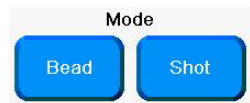

only. Values changed on this

screen independent of changes made on the Maintenance screen.

The Bead Scale value is a duplicate to the Bead Scale setting on the Home Screen, which can be enabled or disabled from the Setup #1 screen. See **Setup #1 Screen** on page 88 for more information.

Fixed Command cc/min

Flow rate can be entered here. This field is only used when command value source is set to Display on Setup Screen 1. See **Setup #1 Screen** on page 88 for more information.

#1 to #6 Buttons

Press to navigate to the Setup Screen with that number. For example, press #3 to navigate to Setup Screen #3.

Pre-Charge

This is the pressure between the meter and the dispense valve when the dispense valve is closed. If the pre-charge setting is non-zero then, immediately after dispensing, the gear meter will continue to rotate after the dispense valve closes until the pre-charge pressure value is achieved. The maximum Pre-Charge value is 2500 psi (17.2 MPa, 172 bar).

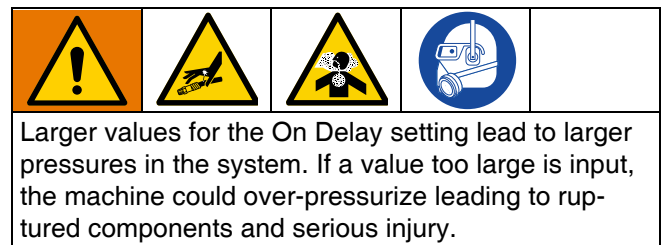

Larger values for the On Delay setting lead to larger pressures in the system. If a value too large is input, the machine could over-pressurize leading to ruptured components and serious injury.

Setup #3 Screen

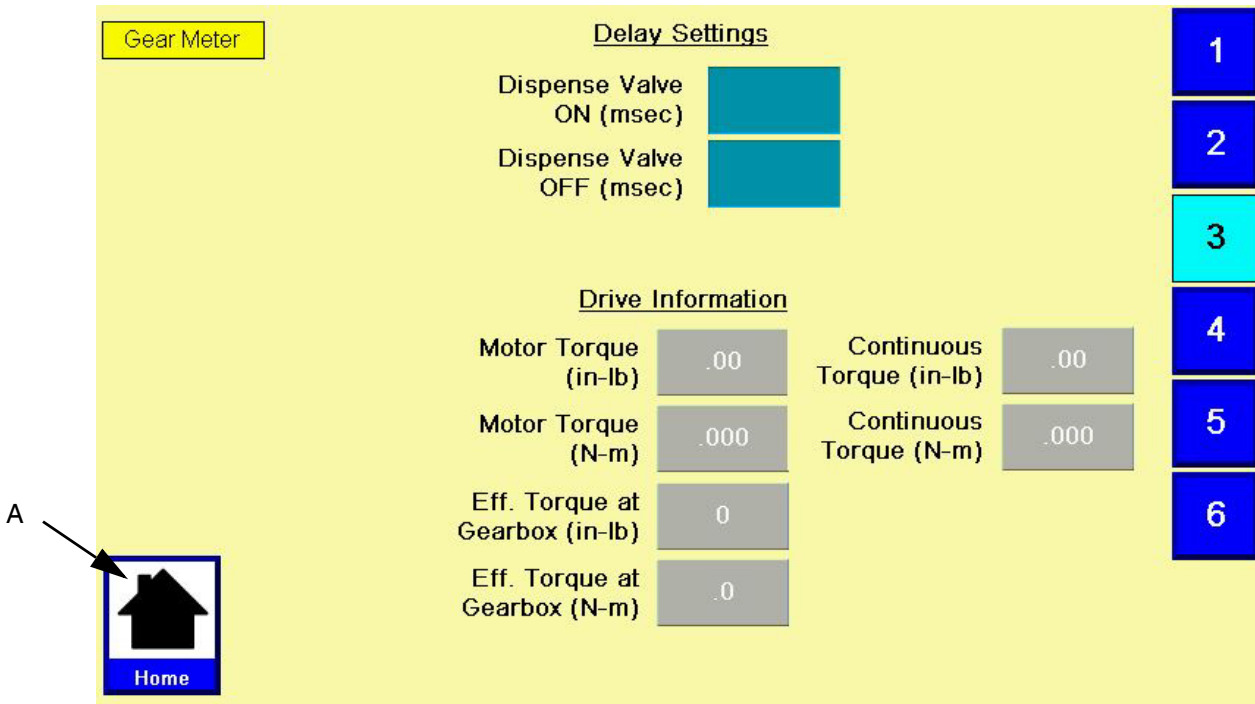

#1 to #6 Buttons

Press to navigate to the Setup Screen with that number. For example, press #3 to navigate to Setup Screen #3.

Delay Settings

Larger values for the On Delay setting lead to larger pressures in the system. If a value too large is input, the machine could over-pressurize leading to ruptured components and serious injury.				

The Delay Settings affect the timing of the Dispense Valve opening and closing when a shot is initiated.

The On Delay is the amount of time, in milliseconds, between a shot being initiated and the dispense valve opening. If the On Delay is set to 100 the machine will wait 100 milliseconds after a shot is initiated before opening the dispense valve. This will lead to a pressure build up between the meter and dispense valve until the dispense valve opens.

The Off Delay is the amount of time, in milliseconds, between a shot completing and the dispense valve closing. If the Off Delay is set to 100 the machine will wait 100 milliseconds after a shot is complete before closing the dispense valve.

Drive Information

Motor Torque

Display motor torque during dispense. If motor torque climbs above continuous torque an alarm is issued. See **Errors** on page 31.

Cont. Torque

Continuous torque rating of the motor.

NOTE: The motor torque display is a good way to determine the maximum flow rate with a given viscosity.

Setup #4 Screen

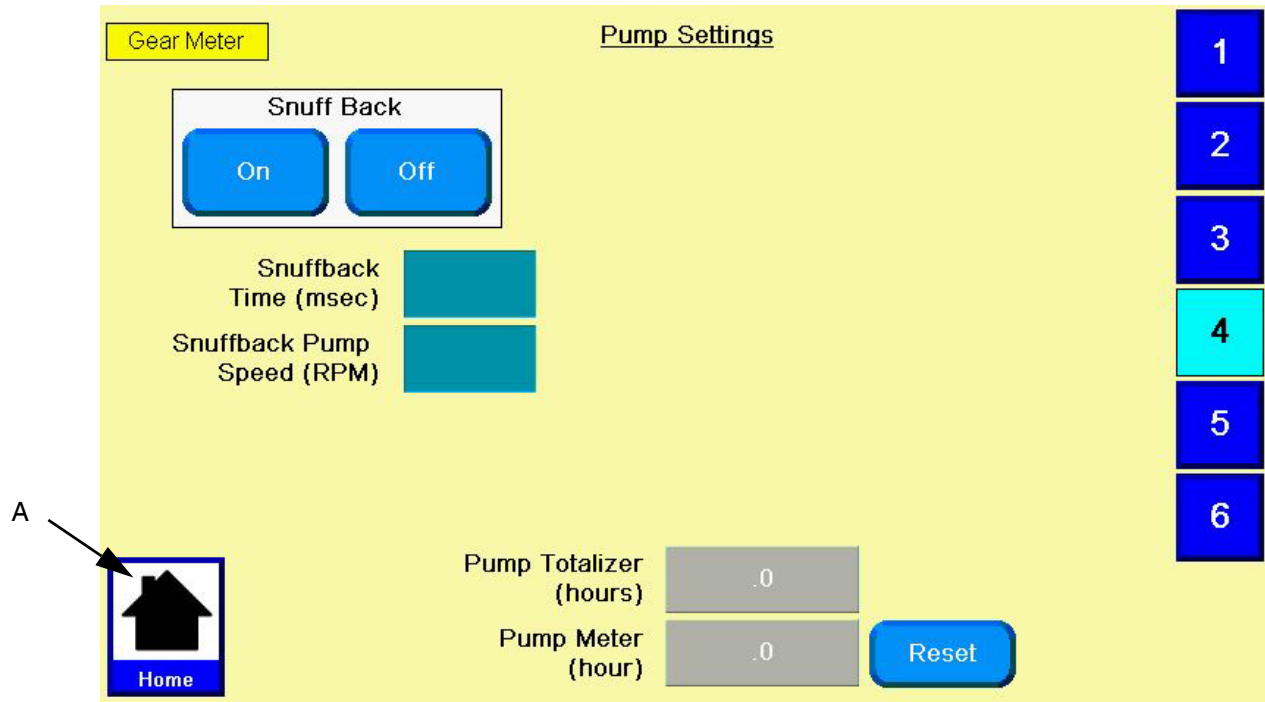

#1 to #6 Buttons

Press to navigate to the Setup Screen with that number. For example, press #3 to navigate to Setup Screen #3.

Pump Settings

Snuff Back: This enables the gear meter to rotate in reverse, immediately following dispensing, to pull material back from the dispense valve to minimize or eliminate material drooling. The Snuff Back Time and Snuff Back Pump RPM are the settings used when Snuff Back is enabled. These settings should be adjusted to work best for your material.

NOTE: Not recommended for very viscous materials.

Pump Hour Totalizer: This field will record the total dispense time on the machine in hours. This field is non-resettable.

Pump Hour Meter: This field displays total dispense time in hours. This field is resettable.

Setup #5 Screen

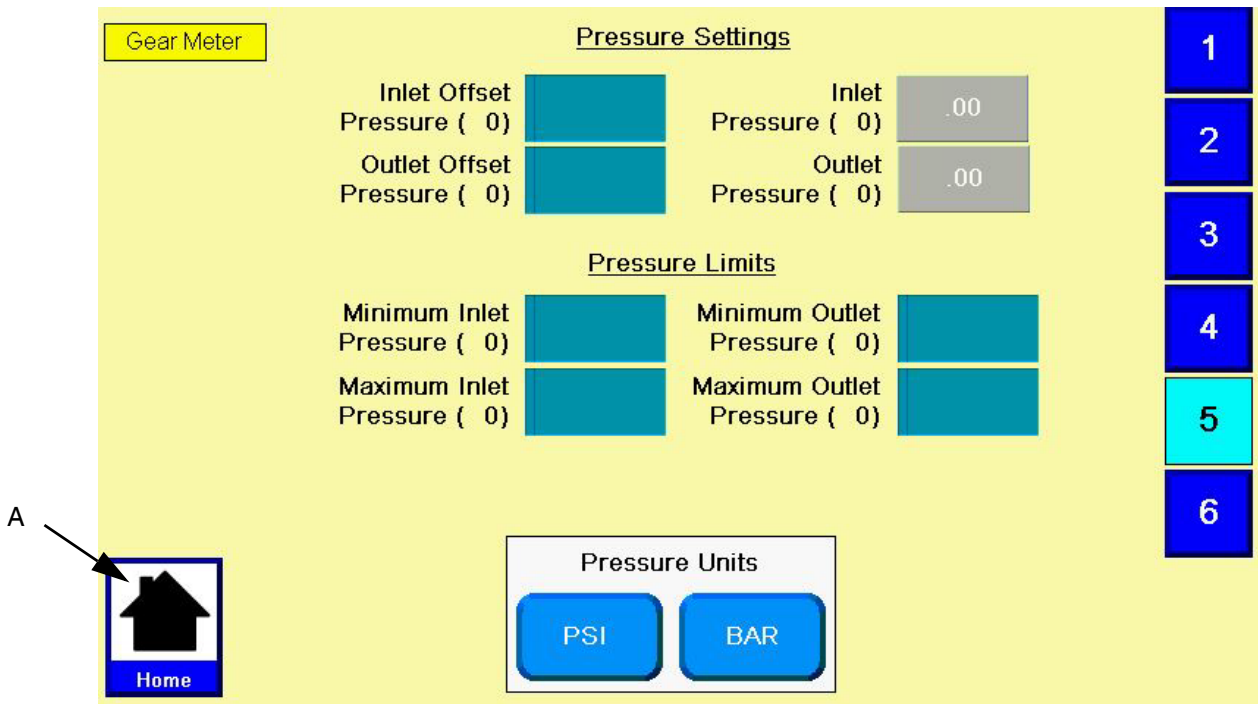

Overview

This screen controls settings for the pressure sensors. These values are used for triggering errors.

#1 to #6 Buttons

Press to navigate to the Setup Screen with that number. For example, press #3 to navigate to Setup Screen #3.

Inlet, Outlet Offset

The inlet, outlet offset values are used to tune the pressure transducer. If the pressure transducers do not register zero pressure when there is no material in the system, enter a value to shift the pressure value to zero. For example, if 15 psi is shown, enter -15 psi to shift the value to 0.

Min/Max Inlet/Outlet Limits

These limit values are used to set the acceptable range of values for dispensing. If values are outside of this range during dispensing the machine will issue an alarm. See **Errors** on page 31.

PSI, BAR

Set the unit of measure for pressure system-wide.

Setup #6 Screen

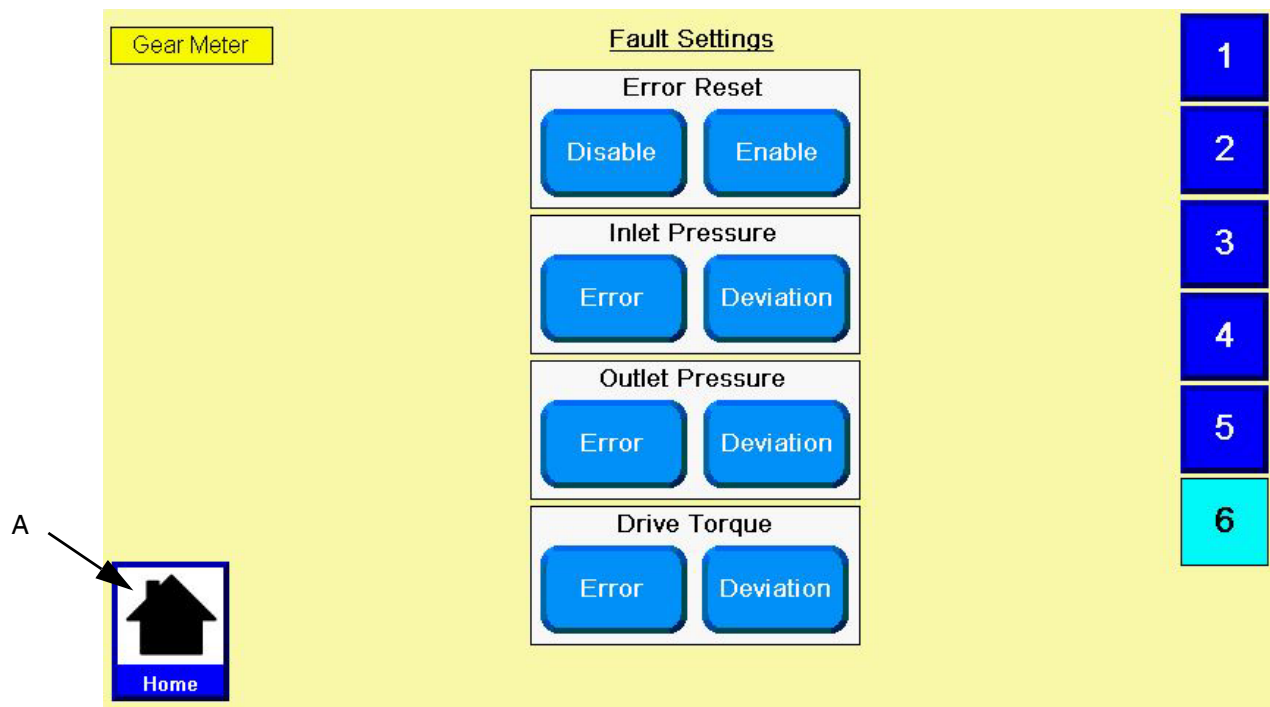

Fault Settings

Error Reset: If set to Disable, errors cannot be reset. If set to Enable, errors can be reset.

Inlet/Outlet Pressure, Drive Torque: If set to Error, an error will be generated when the out-of-limit condition occurs. The machine will be disabled until the error is reset. If set to deviation, an error will be generated when the out-of-limit condition occurs. The machine will not be disabled until the error is reset.

If set to Deviation, an error will be generated when the out-of-limit condition occurs. The machine will not be disabled. See **Errors** on page 31.

Supply Pump Screen

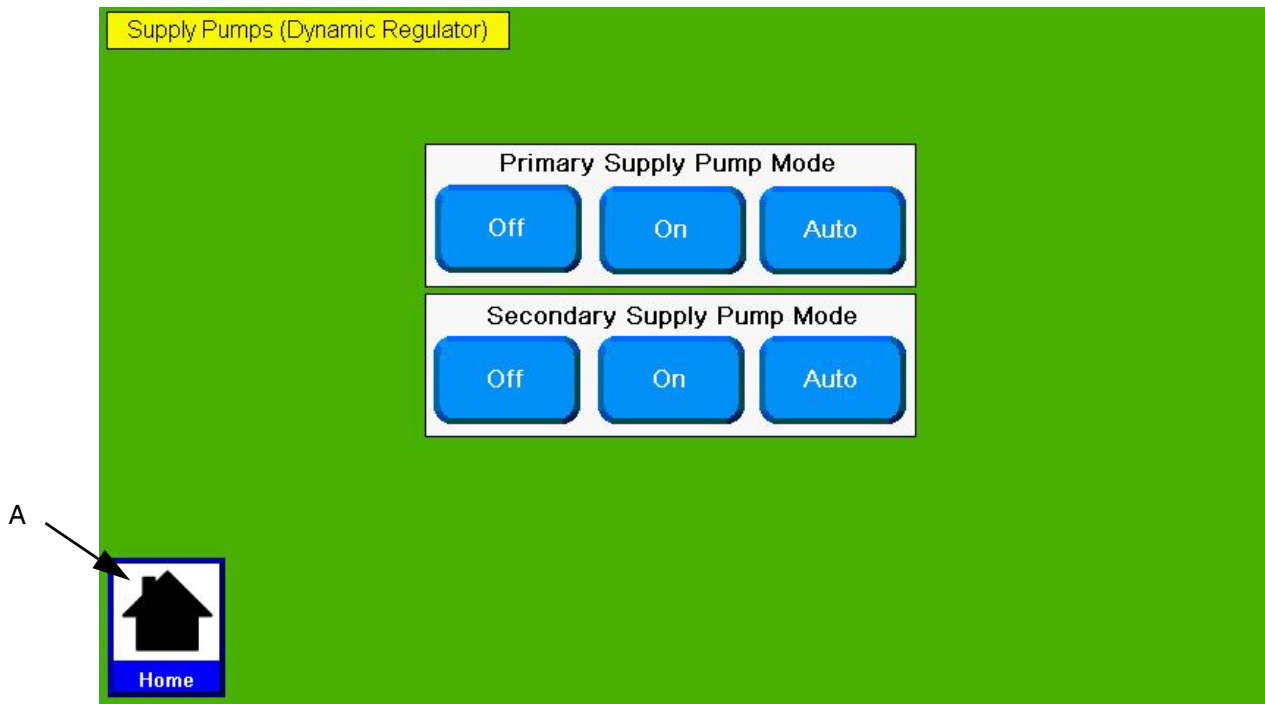

NOTE: This screen is used to control the optional dynamic regulator kit for a Therm-O-Flow. See **Accessory Parts** section on page 74 for additional information on the dynamic regulator kit option.

Supply Pumps (Dynamic Analog Regulator)

Primary Supply Pump Mode

- **Auto Mode:** During normal operation this mode will activate the dynamic regulator solenoid when the dispense valve solenoid is activated.
- **On Mode:** This will activate the dynamic regulator solenoid.
- **Off Mode:** The dynamic regulator option is disabled.

Secondary Supply Pump Mode

- Same control features as primary pump.

Pressure Trend Screen

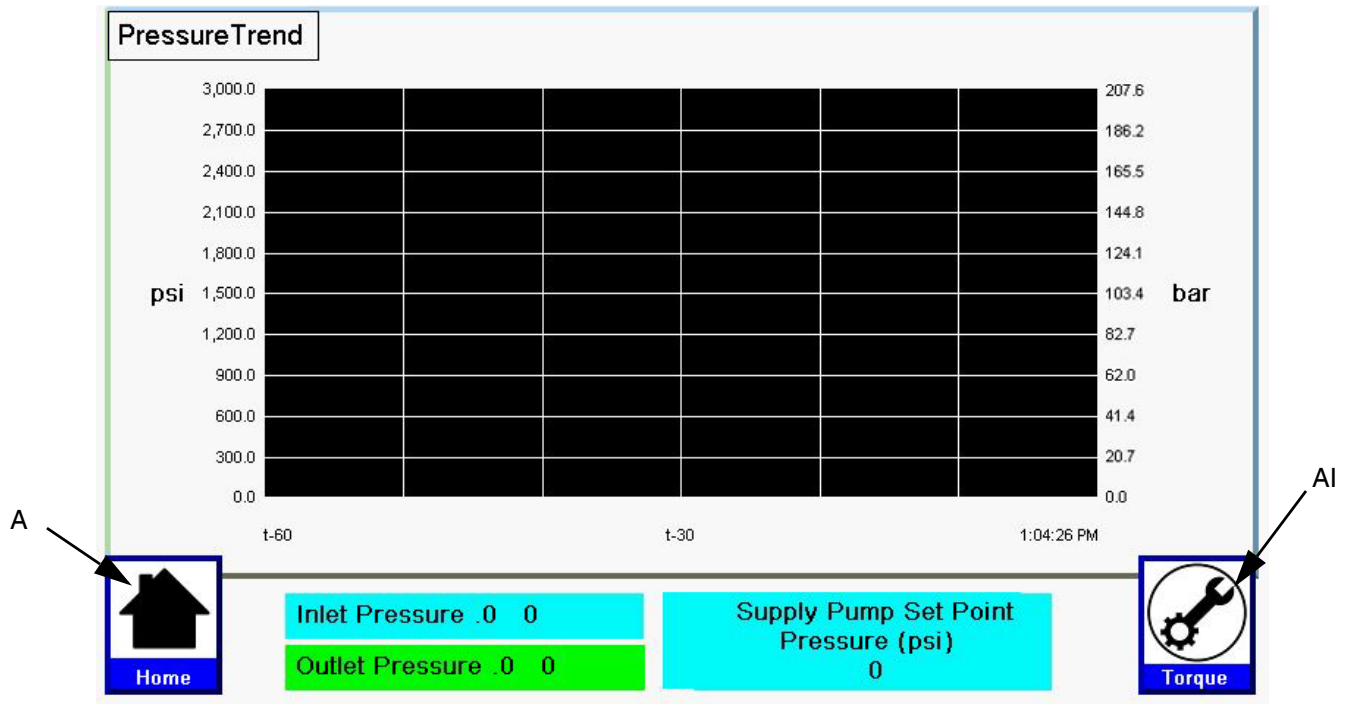

Key:
 AI Navigate to the Torque Trend screen.

Overview

The Pressure Trend screen allows the user to view both inlet and outlet pressures in real time. The pressures displayed on this screen are the same values shown on the Home and Maintenance screens.

Torque Trend Screen

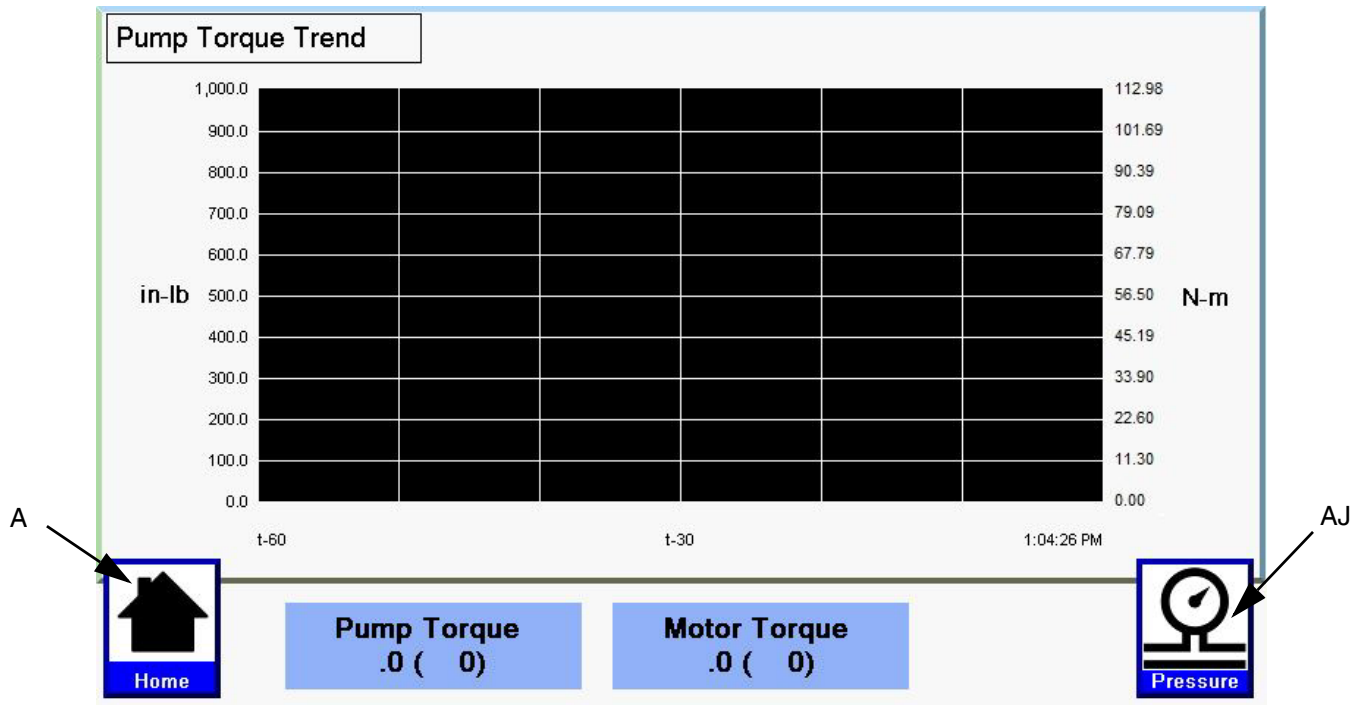

Key:

AJ Navigate to the Pressure Trend screen.

Overview

The Torque Trend screen allows the user to view the pump torque and motor torque in real time.

Pump Torque

The Pump Torque shows the effective torque on the pump during operation.

Motor Torque

The Motor Torque shows the torque on the motor during operation and is measured in in/lbs.

Appendix B - I/O

Using the PGM I/O

The gear meter uses several I/O signals to communicate with plant automation controllers. There are two digital inputs, three digital outputs, and one analog input. All of these signals are routed to the I/O connector on the top of the controller.

Other pins on the I/O connector include 24 VDC power, 24 VDC common, analog common, and a signal which is 24 VDC power only when the controller E-Stop switch is latched in. None of the signals are isolated; all are referenced to the ground plane of the control box. The following paragraphs describe typical connection methods for the automation controller signals.

Digital Inputs

The two digital inputs are Dispense Start and Job Complete. These inputs require a 24 VDC current sourcing output from the automation controller. See FIG. 41.

If the automation controller uses relay contacts to activate I/O signals, the 24 VDC available at the gear meter I/O connector (pin 5) should be used to drive the inputs. If the automation controller uses high-side switching of 24 VDC, the automation outputs can be directly connected to the inputs as long as the 24 VDC common (pin 6) of the gear meter is able to be connected to the automation controller common. If the automation controller outputs are low-side switching (open collector) or a voltage other than 24 VDC, relays must be used as shown in FIG. 41.

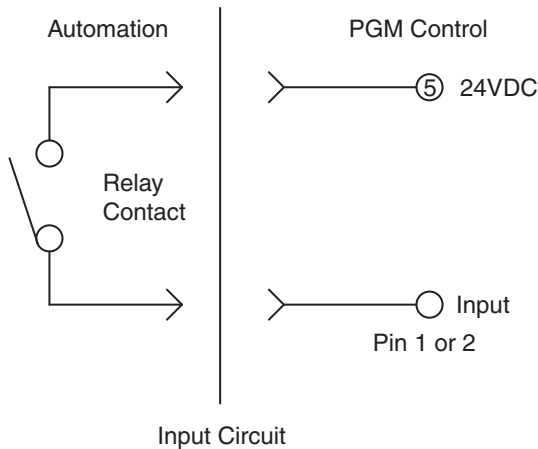

FIG. 41

Digital Outputs

The three digital outputs are Dispenser Ready, Fault Present and In Cycle. These outputs perform high-side switching of 24 VDC and require a 24 VDC current sinking input at the automation controller. See FIG. 42. If the automation controller uses 24 VDC relay coils to receive I/O signals, the signals should be connected as shown in FIG. 42.

If the automation controller inputs are current sourcing or use a voltage other than 24 VDC, relays with 24 VDC coils must be used as shown in FIG. 42.

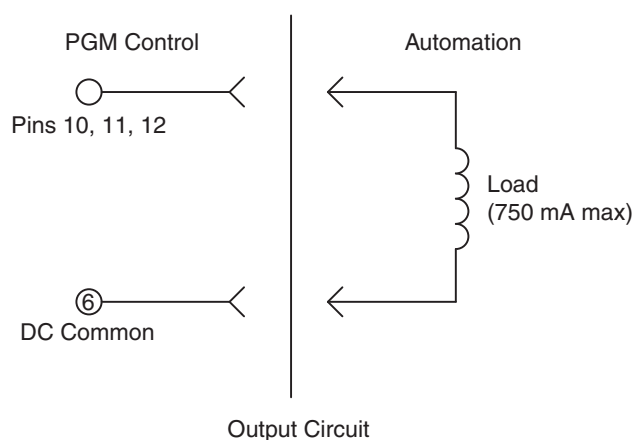

FIG. 42

Analog Inputs

The PGM receives a flow rate analog command from the automation. The 0 to 10 VDC analog input is referenced to analog common on the control. See FIG. 43. The reference for the automation controller analog output must be connected to the PGM analog reference (pin 8) for this signal to function properly.

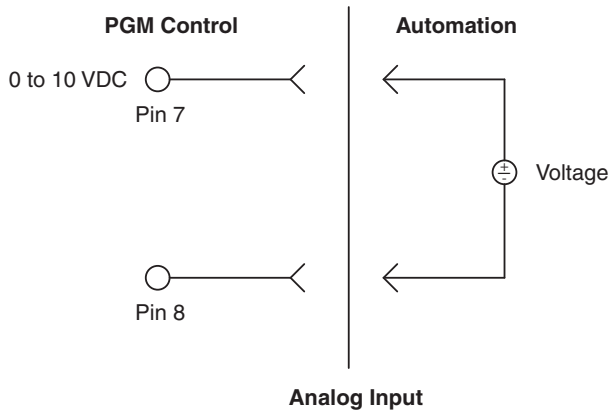

FIG. 43

24 VDC From E-Stop

The PGM provides a signal that can be used by the automation controller to monitor the emergency stop switch position of the PGM controller. See FIG. 44.

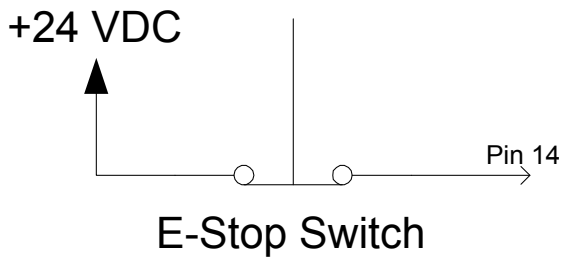

FIG. 44

Relays

If the use of relays is required to condition the digital I/O signals, these are some examples of part numbers that could be used.

For 24 VDC Coils:

- Relay: Phoenix Contact Part Number: 2966171

For 120 VAC Coils:

- Relay: Phoenix Contact Part Number: 2966197

Appendix C - Theory of Operation

Theory of Operation

Input and Output Signals

Terminology

For the purpose of this document a digital signal is said to be SET when voltage is present (or above the minimum threshold). A signal is said to be RESET when the signal voltage is not present (below minimum threshold). **Devices** are referred to as SET when they are in their energized or active state.

Digital Inputs

Dispense Start - This is the Dispense Signal. The PGM unit will attempt to dispense at either the commanded flow rate while this signal is SET, dependent on mode.

Control On - This input is reset when the E-stop button is pressed.

Job Complete - This input can be used to signal a job end.

NOTE: The dispenser ready signal is an important signal for the automation to monitor. When the dispenser ready output is not on, the LT may not be responding to requests from the automation. This could create the situation where the automation is running production, but the PGM is not dispensing any material.

Dispense Valve Solenoid - This signal will be set to energize the dispense valve solenoid at the beginning of a dispense cycle.

Fault Present - This bit is RESET under the following conditions:

- No Faults (alarms or warnings) are active.

In Cycle - In Cycle signal is set at the beginning of a dispense cycle. It is reset at the end of the dispense cycle. The dispense cycle can end in two ways, depending on how the Job End mode is set:

- If the Job End mode is set to remote, dispense cycle ends when the job complete signal is received from the automation I/O.
- If the Job End mode is set to Display, dispense cycle ends when the Job End delay timer expires. See **Appendix A - User Interface Display** on page 82.

Analog Input

Flow Command - The flow command signal input represents flow requests. The voltage must be between 0 and 10 volts DC. The 0-10 volt signal is interpreted as a relative 0-100% flow command signal. The system must be in Remote Mode for this input to be used.

See the **Accessory Parts** on page 74.

Appendix D - Transducer 25E231 Connection

The PGM Ambient Transducer kit 25E231 is used for PGM systems that are independent of the Graco PGM control box. These transducers can be connected to a customer-supplied amplifier or signal conditioner. Refer to these specifications when making connections.

Part Number	16A093
Electrical	
Type	4 wire full bridge
Input Voltage	5 VDC
Span at 3000	104 mV
Span at 5000	173 mV
Zero Offset	4 +/- 2 mV
Input Resistance	< 9K Ω
Output Resistance	3 - 6 K Ω
Mechanical	
Operating Range	0-5000 psi
Max Pressure	5000 psi
Proof Pressure	10,000 psi
Burst Pressure	20,000 psi
Temperature Range	0-85°C (32-185°F)
Cable Length	56 inches
Connector End	M12 male reverse keyed, Reference Turck P/N WASW 4.5-x...

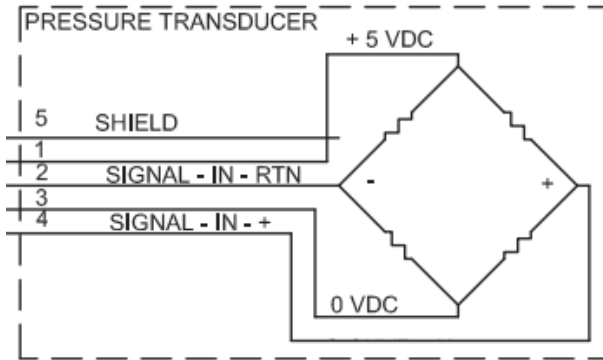

Adapter Cable

NOTE: Adapter cable 128427 can be purchased to adapt the transducer cable to flying leads. Refer to the cable details below.

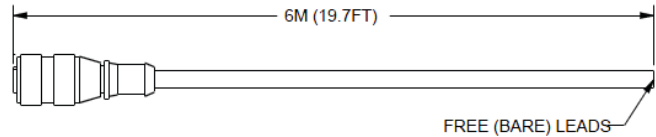

Cable Pinout Connection

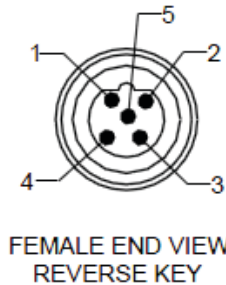
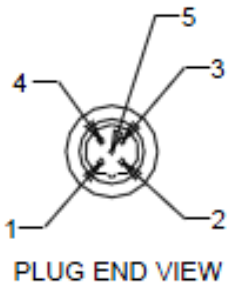

Pin	Cable Color
1	Brown
2	White
3	Blue
4	Black
5	Green/Yellow

M12 Pinout Details		
Pin	Description	Cable Color
1	+ EXE (5 VDC)	Red
2	- Signal	Green
3	- EXE (COM)	Black
4	+ Signal	White
5	Shield Drain	Shield Drain

Technical Specifications

Equipment Name		
	US	Metric
Volume repeatability	+/- 1%	
Maximum Fluid Working Inlet Pressure	1500 psi	10.3 MPa, 103 bar
Maximum Fluid Working Outlet Pressure	2500 psi	17.2 MPa, 172 bar
Air Supply Pressure Range	60-100 psi (filtration required)	
Fluid Filtration Recommended	Up to 200 mesh, depending on viscosity	
Viscosity Range of Fluids	1,000-1,000,000 Centipoise	
Wetted Parts	Stainless Steel, Tool Steel, Chrome, Carbide, Acetal Plastic, PTFE, Chemical Resistant O-Rings	
Power Requirements	Full Load: 18.5A, Fuse Rating: 21A	
Power Supply Voltage Range	240VAC, 50-60 Hz, single phase	
Minimum Flow Rate		
6 cc/rev model	30 cc/min	
20 cc/rev model	40 cc/min	
* Maximum Flow Rate		
6 cc/rev model	480 cc/min	
20 cc/rev model	1600 cc/min	
Minimum Dispensed Shot Size		
6 cc/rev model	8 cc	
20 cc/rev model	10 cc	
Sound Pressure Level at Maximum Flow Rate		
6 cc/rev model	58 dB(A)	
20 cc/rev model	72 dB(A)	
Sound Power Level at Maximum Flow Rate		
6 cc/rev model	68 dB(A)	
20 cc/rev model	79 dB(A)	
Operating Temperature Range		
Control	40-104°F	4-40°C
Heated Pump	40-400°F	4-204°C
Ambient Pump	40-120°F	4-49°C
Operating Humidity Range	10-90% non-condensing	
Weight		
6 cc/rev model	30 lb	13.61 kg
20 cc/rev model	60 lb	27.22 kg
Controls	100 lb	45.36 kg
Overall Dimensions		
6 cc/rev model	19.75 H x 9.38 W x 6.6 D in. (50.17 H x 23.83 W x 16.76 D mm)	
20 cc/rev model	21.75 H x 9.5 W x 8.9 D in. (55.25 H x 24.13 W x 22.6 D mm)	
Control	30 H x 24 W x 12D in. (76.2 H x 60.96 W x 30.48 D mm)	
* Flow rates and viscosities are general estimates. Flow rates drop as viscosity increases. Fluids are expected to shear under pressure. New applications or fluids should always be tested to determine proper line sizes and equipment selections. See your Graco Authorized distributor for other capabilities.		

Graco Standard Warranty

Graco warrants all equipment referenced in this document which is manufactured by Graco and bearing its name to be free from defects in material and workmanship on the date of sale to the original purchaser for use. With the exception of any special, extended, or limited warranty published by Graco, Graco will, for a period of twelve months from the date of sale, repair or replace any part of the equipment determined by Graco to be defective. This warranty applies only when the equipment is installed, operated and maintained in accordance with Graco's written recommendations.

This warranty does not cover, and Graco shall not be liable for general wear and tear, or any malfunction, damage or wear caused by faulty installation, misapplication, abrasion, corrosion, inadequate or improper maintenance, negligence, accident, tampering, or substitution of non-Graco component parts. Nor shall Graco be liable for malfunction, damage or wear caused by the incompatibility of Graco equipment with structures, accessories, equipment or materials not supplied by Graco, or the improper design, manufacture, installation, operation or maintenance of structures, accessories, equipment or materials not supplied by Graco.

This warranty is conditioned upon the prepaid return of the equipment claimed to be defective to an authorized Graco distributor for verification of the claimed defect. If the claimed defect is verified, Graco will repair or replace free of charge any defective parts. The equipment will be returned to the original purchaser transportation prepaid. If inspection of the equipment does not disclose any defect in material or workmanship, repairs will be made at a reasonable charge, which charges may include the costs of parts, labor, and transportation.

THIS WARRANTY IS EXCLUSIVE, AND IS IN LIEU OF ANY OTHER WARRANTIES, EXPRESS OR IMPLIED, INCLUDING BUT NOT LIMITED TO WARRANTY OF MERCHANTABILITY OR WARRANTY OF FITNESS FOR A PARTICULAR PURPOSE.

Graco's sole obligation and buyer's sole remedy for any breach of warranty shall be as set forth above. The buyer agrees that no other remedy (including, but not limited to, incidental or consequential damages for lost profits, lost sales, injury to person or property, or any other incidental or consequential loss) shall be available. Any action for breach of warranty must be brought within two (2) years of the date of sale.

GRACO MAKES NO WARRANTY, AND DISCLAIMS ALL IMPLIED WARRANTIES OF MERCHANTABILITY AND FITNESS FOR A PARTICULAR PURPOSE, IN CONNECTION WITH ACCESSORIES, EQUIPMENT, MATERIALS OR COMPONENTS SOLD BUT NOT MANUFACTURED BY GRACO. These items sold, but not manufactured by Graco (such as electric motors, switches, hose, etc.), are subject to the warranty, if any, of their manufacturer. Graco will provide purchaser with reasonable assistance in making any claim for breach of these warranties.

In no event will Graco be liable for indirect, incidental, special or consequential damages resulting from Graco supplying equipment hereunder, or the furnishing, performance, or use of any products or other goods sold hereto, whether due to a breach of contract, breach of warranty, the negligence of Graco, or otherwise.

FOR GRACO CANADA CUSTOMERS

The Parties acknowledge that they have required that the present document, as well as all documents, notices and legal proceedings entered into, given or instituted pursuant hereto or relating directly or indirectly hereto, be drawn up in English. Les parties reconnaissent avoir convenu que la rédaction du présente document sera en Anglais, ainsi que tous documents, avis et procédures judiciaires exécutés, donnés ou intentés, à la suite de ou en rapport, directement ou indirectement, avec les procédures concernées.

Graco Information

Sealant and Adhesive Dispensing Equipment

For the latest information about Graco products, visit www.graco.com.

For patent information, see www.graco.com/patents.

TO PLACE AN ORDER, contact your Graco distributor, go to www.graco.com and select "Where to Buy" in the top blue bar, or call to find the nearest distributor.

If calling from the US: 800-746-1334

If calling from outside the US: 0-1-330-966-3000

All written and visual data contained in this document reflects the latest product information available at the time of publication. Graco reserves the right to make changes at any time without notice.

Original instructions. This manual contains English. MM 3A5185

Graco Headquarters: Minneapolis

International Offices: Belgium, China, Japan, Korea

GRACO INC. AND SUBSIDIARIES • P.O. BOX 1441 • MINNEAPOLIS MN 55440-1441 • USA
Copyright 2017, Graco Inc. All Graco manufacturing locations are registered to ISO 9001.

www.graco.com
Revision F, July 2018